

APPENDIX B: Baseline Water Resources Monitoring and Hydrogeological Investigations Report

Note: The Baseline Water Resource Monitoring and Hydrogeological Investigation Report summarizes data collected from 2011 through July 2015. Subsequent data is summarized in individual hydrological investigation reports Appendix B-1 (CTF Hydrological Investigation) and B-2 (Easter UIG Hydrological Investigation). Appendices B-A through B-D of this MOP Application include the water quality data, statistics, well logs, and aquifer test analysis conducted from 2011 through 2016.

- B-A. Appendix A Baseline Water Quality Database (Electronic Only)**
- B-B. Appendix B Baseline Water Quality Statistics**
- B-C. Appendix C Well Logs**
- B-D. Appendix D Aquifer Test Analyses**

**BASELINE WATER RESOURCES MONITORING AND
HYDROGEOLOGIC INVESTIGATIONS REPORT
TINTINA RESOURCES BLACK BUTTE PROJECT**

Prepared for:

Tintina Alaska Exploration Inc.
Suite 2560-200 Granville Street
Vancouver, BC, Canada V6C1S4

Prepared by:

Hydrometrics, Inc.
3020 Bozeman Avenue
Helena, MT 59601

August 2015
(Revised March 2017)

TABLE OF CONTENTS

LIST OF TABLES iii

LIST OF FIGURES iii

LIST OF APPENDICES iv

1.0 INTRODUCTION 1-1

 1.1 HYDROLOGIC SETTING 1-9

 1.1.1 Surface Water 1-9

 1.1.2 Groundwater 1-13

2.0 BASELINE MONITORING 2-1

 2.1 SURFACE WATER MONITORING 2-1

 2.1.1 Stream Flows 2-4

 2.1.2 Surface Water Quality 2-8

 2.2 GROUNDWATER 2-9

 2.2.1 Geology/Hydrostratigraphy 2-9

 2.2.2 Groundwater Flow Directions 2-14

 2.2.3 Groundwater Quality 2-18

 2.3 SEEPS AND SPRINGS DELINEATION 2-20

 2.3.1 Spring Flow Rates and Water Quality 2-20

3.0 AQUIFER CHARACTERIZATION INVESTIGATIONS 3-1

4.0 GROUNDWATER SURFACE WATER INTERACTIONS 4-1

 4.1 SHEEP CREEK 4-1

 4.2 BRUSH CREEK AND COON CREEK 4-5

5.0 REFERENCES 5-1

LIST OF TABLES

TABLE 1.	SAMPLING SUMMARY FOR BASELINE MONITORING SITES	1-6
TABLE 2.	PARAMETERS, METHODS, AND DETECTION LIMITS FOR BASELINE SURFACE WATER MONITORING.....	2-2
TABLE 3.	PARAMETERS, METHODS, AND DETECTION LIMITS FOR BASELINE GROUNDWATER MONITORING	2-3
TABLE 4.	SUMMARY OF STREAM FLOW MONITORING DATA.....	2-8
TABLE 5.	WELL COMPLETION DATA	2-15
TABLE 6.	SUMMARY OF BASELINE SPRING FLOW DATA	2-21
TABLE 7.	SUMMARY OF AQUIFER TEST RESULTS	3-2
TABLE 8.	FLEX WALL PERMEABILITY TEST RESULTS FOR VOLCANO VALLEY FAULT SOIL SAMPLES	3-5
TABLE 9.	AUGUST 2012 SYNOPTIC SURVEY RESULTS.....	4-3
TABLE 10.	OCTOBER 2012 SYNOPTIC FLOW RESULTS	4-4

LIST OF FIGURES

FIGURE 1.	LOCATION MAP	1-2
FIGURE 2.	SURFACE WATER RESOURCE MONITORING SITES	1-3
FIGURE 3.	GROUNDWATER MONITORING SITES	1-4
FIGURE 4.	BASELINE SPRING AND SEEP SITES.....	1-5
FIGURE 5.	MAJOR CREEKS AND TRIBUTARIES	1-10
FIGURE 6.	MEAN DAILY FLOW HYDROGRAPH AT USGS SITE ON SHEEP CREEK.....	1-12
FIGURE 7.	STREAMFLOW COMPARISON AT SHEEP CREEK MONITORING SITES	2-5
FIGURE 8.	RATING CURVE OF SW-1 SHEEP CREEK MONITORING SITE	2-6
FIGURE 9.	HYDROGRAPH OF SW-1 SHEEP CREEK MONITORING SITE	2-7
FIGURE 10.	SITE GEOLOGIC MAP SHOWING COPPER-RICH DEPOSITS	2-11

FIGURE 11.	GENERALIZED CROSS-SECTION WITH WELL LOCATIONS.....	2-12
FIGURE 12.	SCHEMATIC DIAGRAM OF HYDROSTRATIGRAPHIC UNITS AND ASSOCIATED WELL COMPLETIONS	2-13
FIGURE 13.	POTENTIOMETRIC SURFACE MAP.....	2-16
FIGURE 14.	2012 SYNOPTIC SURVEY SITES.....	4-2

LIST OF APPENDICES

APPENDIX A	WATER QUALITY MONITORING DATABASE (LOCATED ON CD)
APPENDIX B	WATER QUALITY STATISTICS
APPENDIX C	WELL LOGS
APPENDIX D	AQUIFER TEST ANALYSES

BASELINE WATER RESOURCES MONITORING AND HYDROGEOLOGIC INVESTIGATIONS REPORT TINTINA RESOURCES BLACK BUTTE PROJECT

1.0 INTRODUCTION

Tintina Resources, Inc.'s (Tintina) has conducted both water resource baseline monitoring and hydrologic investigations for the Black Butte Copper Project located north of White Sulphur Springs, Montana (Figure 1). These investigations were conducted in support of permitting activities for the exploration and development of copper-bearing massive sulfide deposits within the lower Newland Formation. This report summarizes the results to date from the baseline monitoring program and hydrologic investigations.

Baseline monitoring for this project was initiated in May of 2011 and entails measurement of flow, water levels, and water quality at surface water, groundwater, and spring and seep monitoring sites in the project area. Quarterly sampling is conducted at 11 surface water sites (Figure 2) and 11 monitoring wells (Figure 3). Surface water data collection consists of baseline water quality sampling and analysis, and flow measurements. Surface water monitoring at sites on Sheep Creek has been conducted on a bi-weekly/weekly schedule during spring run-off since 2013; monthly monitoring has been conducted at these sites since 2014. Spring and seep monitoring is also conducted annually and includes monitoring of flow and field parameters at 16 springs; 11 of the spring monitoring sites have been sampled for water quality analysis (Figure 4). Field parameters are also monitored annually at ten seep locations. Groundwater monitoring is conducted quarterly at 12 monitoring well sites, and static water levels are measured quarterly at 22 additional test wells and piezometer sites. Water quality data have also been collected at ten test wells during site investigations (PW series wells shown on Figure 3); however, these wells are not routinely monitored during baseline monitoring events. Table 1 summarizes the type of baseline data available and period of record at each of the sites.

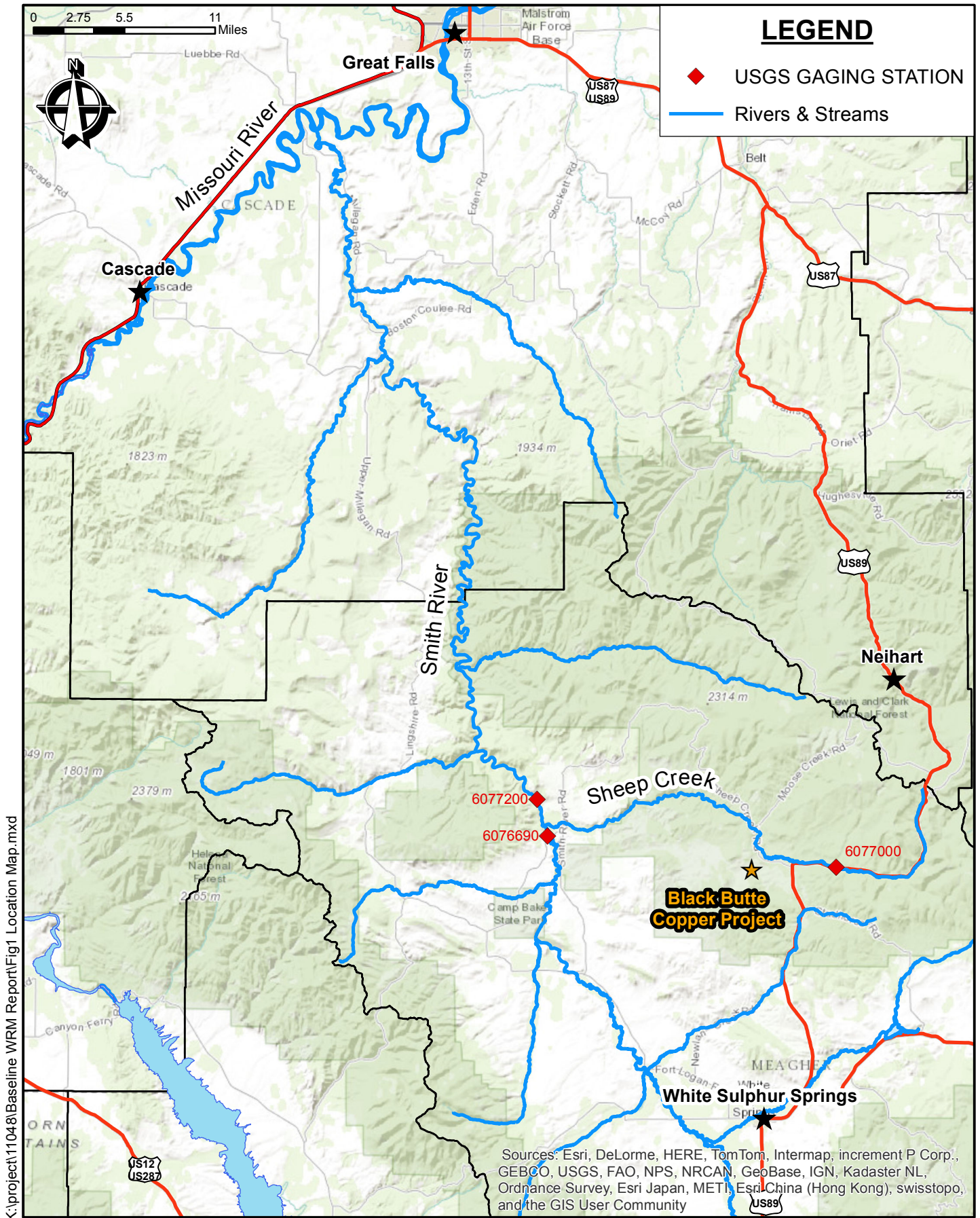

K:\project\11048\Baseline WRM Report\Fig1 Location Map.mxd

Figure 1
Location Map
Black Butte Copper Project
Meagher County, Montana

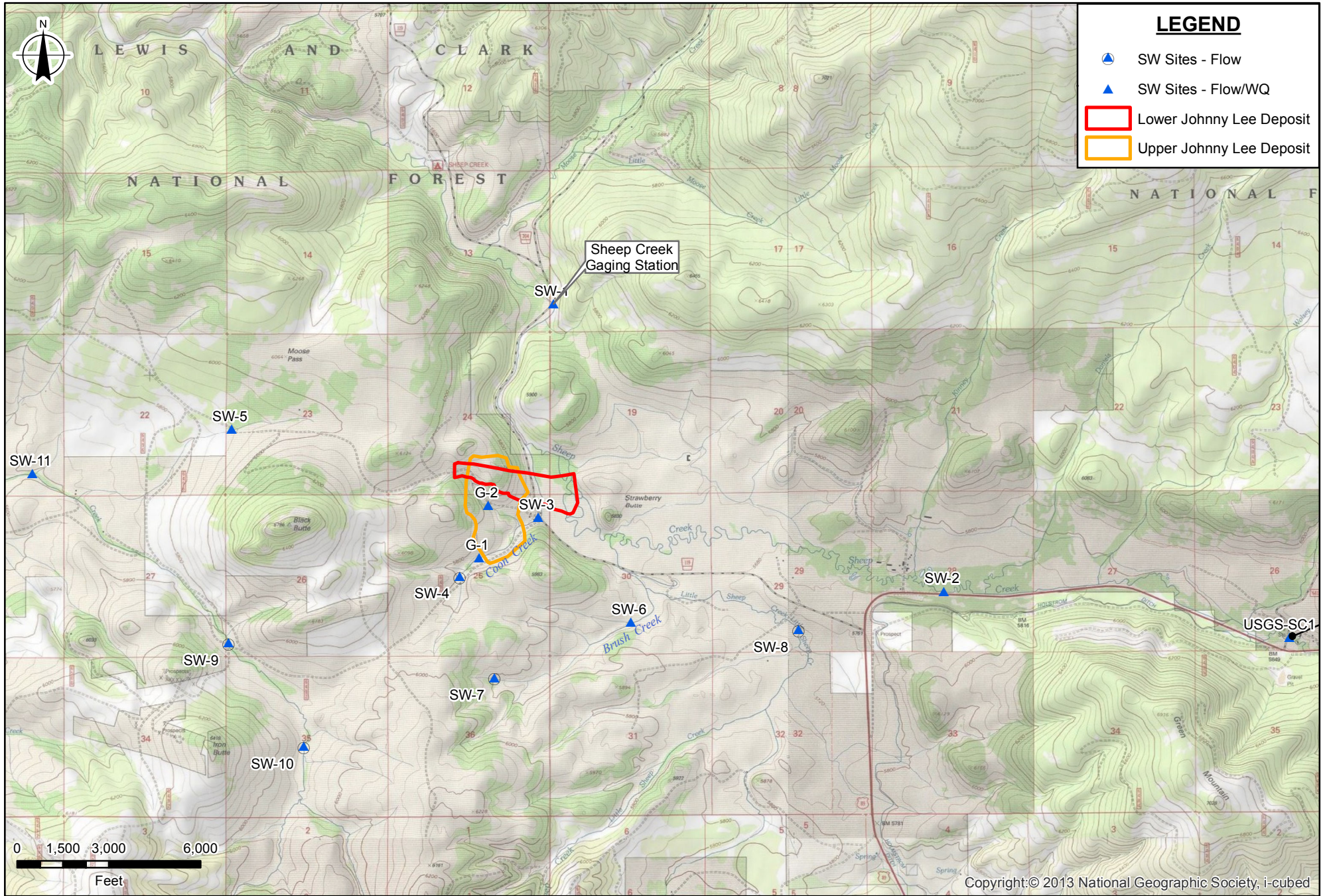

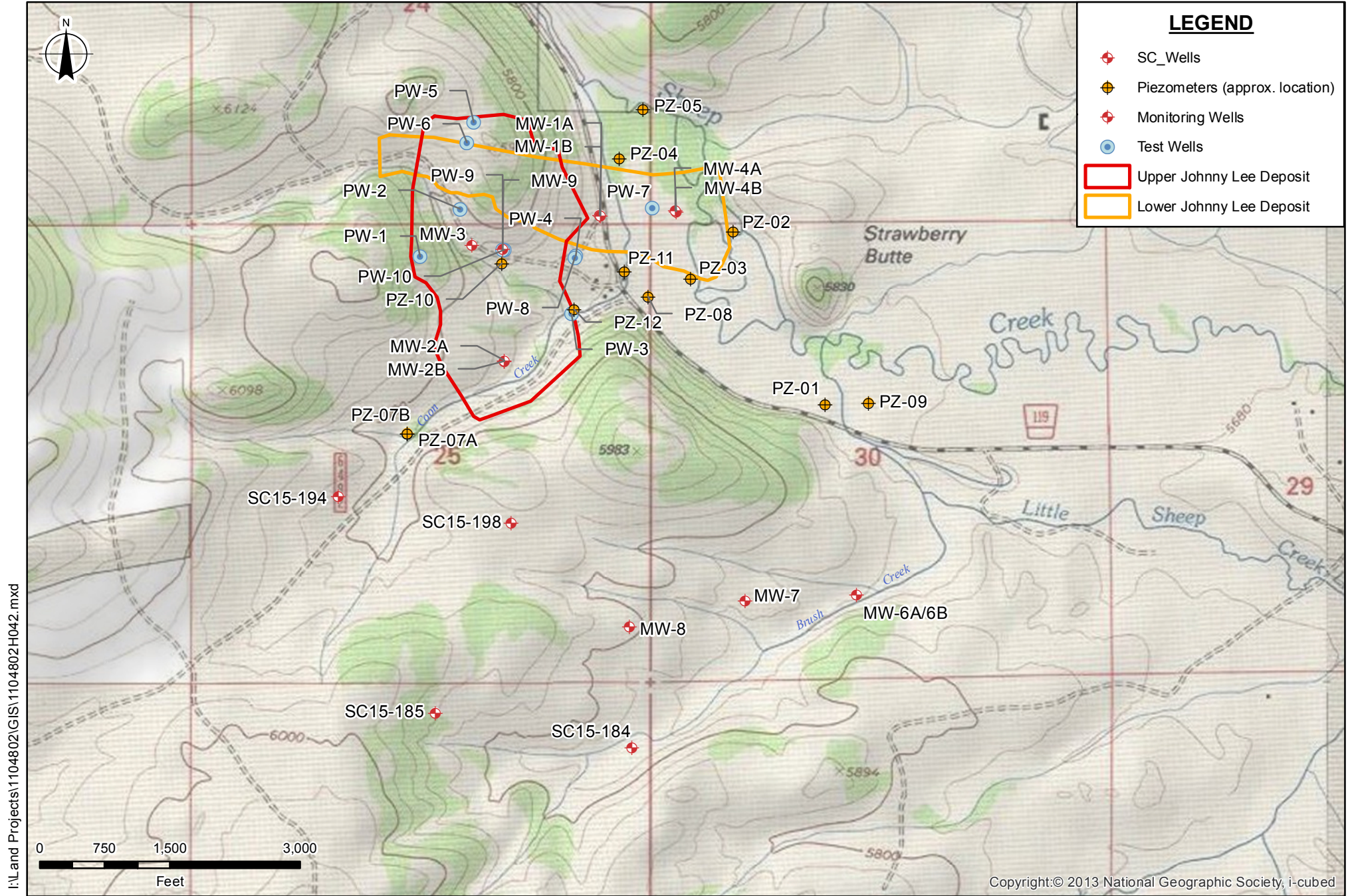

Copyright:© 2013 National Geographic Society, i-cubed

Figure 3
Groundwater Monitoring Sites
 Black Butte Copper Project
 Meagher County, Montana

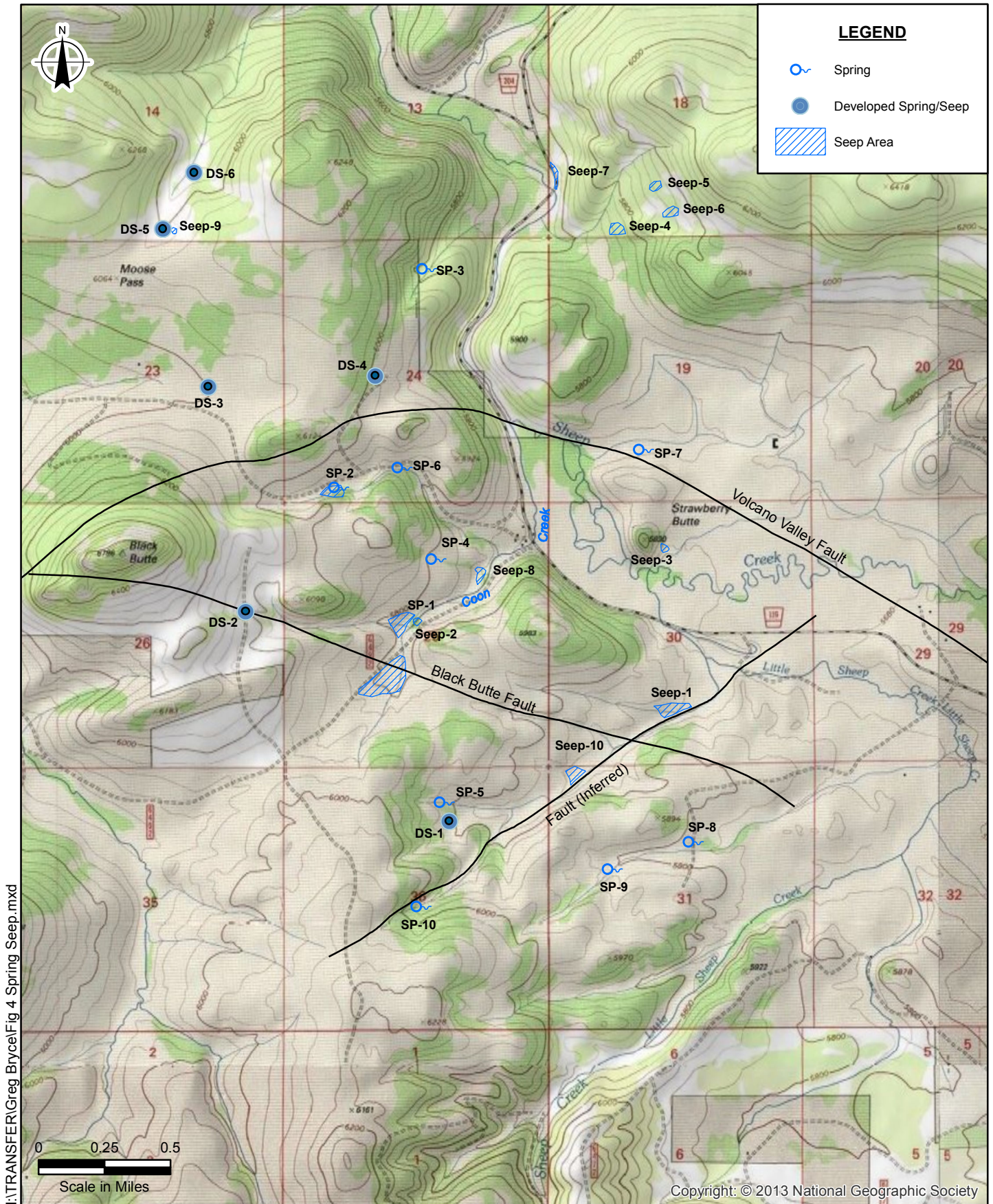

I:\TRANSFER\Greg Bryce\Fig 4 Spring Seep.mxd

Figure 4
Baseline Spring and Seep Sites
Black Butte Copper Project
Meagher County, Montana

TABLE 1. SAMPLING SUMMARY FOR BASELINE MONITORING SITES

Monitoring Site	Easting (meters)	Northing (meters)	Monitoring Frequency	Period of record	Flow or Water Level	Field Parameters	Lab Parameters	Comments
	UTM-WGS 1984 Zone 12							
Developed Springs								
DS-1	506507.08	5178870.812	Annual	2011-2015	X	X	2015	
DS-2	505263.49	5180150.611	Annual	2011-2015	X	X	2011, 2014	
DS-3	505037.62	5181520.613	Annual	2011-2015	X	X	2014-2015	
DS-4	506056.53	5181588.636	Annual	2011-2015	X	X	2011,14,15	
DS-5	504761.45	5182484.963	Annual	2011-2014	X	X	--	
DS-6	504949.66	5182827.876	Annual	2011-2014	X	X	--	
Seeps								
Seep-1	507876.19	5179570.54	Annual	2011-2014	--	X	--	
Seep-2	506310.6	5180089.2	Annual	2012-2014	--	X	--	
Seep-3	507821.16	5180537.25	Annual	2012-2014	--	X	--	
Seep-4	507530.57	5182486.29	Annual	2012-2014	--	X	--	
Seep-5	507768.38	5182748.77	Annual	2011-2014	--	X	--	
Seep-6	507853.49	5182587.27	Annual	2011-2014	--	X	--	
Seep-7	507155.4	5182821.06	Annual	2011-2014	--	--	--	
Seep-8	506701.44	5180381.64	Annual	2011-2014	--	X	--	
Seep-9	504825.48	5182475.68	Annual	2012-2014	--	X	--	
Seep-10	507270.05	5179164.8	Annual	2012-2014	--	X	--	
Springs								
SP-1	506273	5180099	Annual	2011-2015	X	X	2011,14,15	
SP-2	505833.97	5180907.344	Annual	2011-2015	X	X	X	2013, no Lab Data
SP-3	506370.58	5182241.552	Annual	2011-2015	X	X	X	
SP-4	506425.17	5180468.941	Annual	2011-2015	X	X	X	
SP-5	506478.82	5178985.422	Annual	2011-2015	X	X	--	
SP-6	506219.58	5181027.89	Annual	2011-2015	X	X	X	
SP-7	507693.69	5181137.92	Annual	2011-2015	X	X	2015	
SP-8	507995.89	5178745.244	Annual	2012-2014	X	X	--	
SP-9	507502.03	5178577.924	Annual	2012-2014	X	X	--	
SP-10	506335.42	5178351.003	Annual	2012-2014	X	X	--	

TABLE 1. SAMPLING SUMMARY FOR BASELINE MONITORING SITES

Monitoring Site	Easting (meters)	Northing (meters)	Monitoring Frequency	Period of record	Flow or Water Level	Field Parameters	Lab Parameters	Comments
	UTM-WGS 1984 Zone 12							
Surface Water Sites								
SW-1	507148	5182710	Monthly	2011-2015	X	X	X	Hourly water level data since 2012; High flow bi-weekly/weekly Flow
SW-2	511040	5179844	Monthly	2011-2015	X	X	X	High flow bi-weekly/weekly Flow
SW-3	506996	5180581	Quarterly	2011-2015	X	X	X	
SW-4	506308	5180114	Quarterly	2011-2015	X	X	--	
SW-5	503914	5181465	Quarterly	2011-2015	X	X	X	Typically Dry
SW-6	507919	5179536	Quarterly	2011-2015	X	X	X	
SW-7	506420	5179000	Quarterly	2011-2015	X	X	2012,15	
SW-8	509575	5179476	Quarterly	2011-2015	X	X	--	
SW-9	503944	5179271	Quarterly	2011-2015	X	X	--	
SW-10	504665	5178322	Quarterly	2011-2015	X	X	2015	Added Lab WQ for TMDL
SW-11	501951	5181021	Quarterly	2011-2015	X	X	X	
USGS-SC1	514509	5179419	Monthly	2014-2015	X	X	X	High flow bi-weekly/weekly Flow
G-1	506405.3	5180177.74	Single Event	July 2011	X	X	X	Data collected once only in July 2011
G-2	506497.29	5180699.41	Single Event	July 2011	X	X	X	Data collected once only in July 2011
Monitoring Wells								
MW-1A	506935.22	5180841.55	Quarterly	2011-2015	X	X	X	
MW-1B	506934.19	5180845.46	Quarterly	2011-2015	X	X	X	
MW-2A	506598.18	5180331.93	Quarterly	2011-2015	X	X	X	
MW-2B	506596.96	5180328.73	Quarterly	2011-2015	X	X	X	
MW-3	506484.1	5180740.2	Quarterly	2011-2015	X	X	X	
MW-4A	507201.5	5180855.4	Quarterly	2012-2015	X	X	X	
MW-4B	507200.1	5180858.5	Quarterly	2012-2015	X	X	X	
MW-6A	507809.2	5179492.9	Quarterly	2013-2015	X	X	X	
MW-6B	507792.8	5179490.7	Quarterly	2013-2015	X	X	X	
MW-7	507451.7	5179500.7	Quarterly	2013-2015	X	X	X	
MW-8	507036.0	5179398.3	Quarterly	2013-2015	X	X	X	
MW-9	506593.0	5180725.5	Quarterly	2014-2015	X	X	X	
SC15-184	507047.3	5178972.5	Quarterly	2015	X	X	X	first monitoring July 2015
SC15-185	506355.5	5179094.2	Quarterly	2015	X	X	X	first monitoring July 2015
SC15-194	506014.1	5179854.9	Quarterly	2015	X	X	X	first monitoring July 2015
SC15-198	506621.4	5179854.9	Quarterly	2015	X	X	X	first monitoring July 2015

TABLE 1. SAMPLING SUMMARY FOR BASELINE MONITORING SITES

Monitoring Site	Easting (meters)	Northing (meters)	Monitoring Frequency	Period of record	Flow or Water Level	Field Parameters	Lab Parameters	Comments
	UTM-WGS 1984 Zone 12							
Test Wells								
PW-1	506301.4	5180698.4	Quarterly	2011-2015	X	One Time	One Time	Lab Data from Pumping Test
PW-2	506443.2	5180865.0	Quarterly	2011-2015	X	One Time	One Time	Lab Data from Pumping Test
PW-3	506846.4	5180479.4	Quarterly	2012-2015	X	Twice	Twice	Lab Data from Pumping Test
PW-4	506901.8	5180688.3	Quarterly	2012-2015	X	One Time	One Time	Lab Data from Pumping Test
PW-5	506490.7	5181172.8	Quarterly	2013-2015	X	--	--	
PW-6	506468.1	5181097.9	Quarterly	2012-2015	X	--	--	Lab Data from Pumping Test
PW-6N	506468.1	5181097.9	Quarterly	2015	X	--	--	
PW-7	506846.2	5180695.5	Quarterly	2013-2015	X	Twice	Twice	Lab Data from Pumping Test
PW-8	506598.4	5180721.9	Quarterly	2014-2015	X	Twice	Twice	Lab Data from Pumping Test
PW-10	506593.6	5180721.9	Quarterly	2014-2015	X	Twice	Twice	Lab Data from Pumping Test
Piezometers								
PZ-01	507650.0	5180255.6	Quarterly	2012-2014	X	--	--	
PZ-02	507400.7	5180778.8	Quarterly	2012-2014	X	--	--	
PZ-03	507249.2	5180618.9	Quarterly	2012-2015	X	--	--	
PZ-04	506991.7	5181110.8	Quarterly	2012-2015	X	--	--	
PZ-05	507080.0	5181214.7	Quarterly	2012-2015	X	--	--	
PZ-07A	506258.4	5180074.7	Quarterly	Nov-14	X	--	--	
PZ-07B	506258.5	5180075.0	Quarterly	Nov-14	X	--	--	
PZ-08	507090.3	5180573.8	Quarterly	2014-2015	X	--	--	
PZ-09	507883.8	5180178.6	Quarterly	2014-2015	X	--	--	
PZ-10	506589.2	5180672.5	One-Time	Nov-14	X	--	--	PW-8 Aq Test temporary piezometers
PZ-11	507020.6	5180642.8	Twice	Nov-14, Mar-15	X	--	--	PW-8 Aq Test temporary piezometers
PZ-12	506844.4	5180513.8	One-Time	Nov-14	X	--	--	PW-8 Aq Test temporary piezometers

In addition to baseline monitoring, a number of groundwater investigations have been conducted to characterize hydrostratigraphic units in the project area (Hydrometrics, 2012c, 2013a, and 2015). In addition, investigations have been conducted of groundwater/surface water interactions for a possible Land Application Disposal (LAD) area (Hydrometrics, 2013a), and two synoptic surveys were conducted on Sheep Creek between Little Sheep Creek and downgradient monitoring site SW-1.

1.1 HYDROLOGIC SETTING

1.1.1 Surface Water

The project area is in the upper portion of the Sheep Creek drainage, a tributary to the Smith River, which in turn is a tributary of the Missouri River (Figure 1). Sheep Creek is a fifth order stream draining a total of approximately 194 square miles. Sheep Creek originates in the Little Belt Mountains at an elevation of about 7,400 feet and discharges to the Smith River approximately 34 river miles to the west at an elevation of 4,380 feet. The project area is located in the approximate upper third of the drainage. The project area is approximately 19 river miles above the confluence with the Smith River. Sheep Creek is a high quality stream that flows in a meandering channel through a broad alluvial valley upstream of the project site but enters a constricted bedrock canyon just downstream. It is used principally for stock water and fishing (RMI, 2010).

Primary tributaries to Sheep Creek in the immediate project area include Little Sheep Creek and Coon Creek (Figure 5). Little Sheep Creek is located southeast of the project area and converges with an unnamed tributary (referred to here as Brush Creek) approximately half a mile south of Strawberry Butte. Coon Creek follows Butte Creek Road east of Black Butte and joins Sheep Creek at the head of a canyon located almost one mile northwest of Strawberry Butte (Figure 5). To the west of Black Butte is Black Butte Creek, also a tributary to Sheep Creek. Black Butte Creek flows to the northwest and joins Sheep Creek approximately seven miles to the west-northwest of Black Butte. There is a small unnamed tributary that joins Sheep Creek on the north side of Strawberry Butte that collects water from springs on the north flank of the Sheep Creek Valley. Another small un-named



Document Path: I:\TRANSFER\Greg Bryce\1104802\H004_GTB.mxd

Copyright © 2013 National Geographic Society, i-cubed

Figure 5
Major Creeks and Tributaries
Black Butte Copper Project
Meagher County, Montana

tributary flows westward from the northern side of Black Butte into Black Butte Creek. Flow in these tributary drainages is only perennial on their lower reaches and ephemeral upstream.

The United States Geological Survey (USGS) historically operated a gaging station on Sheep Creek (USGS 06077000) that was located approximately four miles upstream of the project site (Figure 5). Stream flow in Sheep Creek was gaged at this site from 1941 through 1978, and the USGS reports average monthly flows ranging from approximately 9 cfs to 115 cfs. A hydrograph of the average daily discharge at the former Sheep Creek gaging station is shown on Figure 6. The nearest active USGS gaging stations (USGS 06076690 and 06077200) are located on the Smith River just above the confluence with Sheep Creek near Fort Logan and just below the confluence with Sheep Creek and Eagle Creek (Figure 1). The upstream gaging station (06076690) was monitored continuously from October 1977 to the end of September 1996. The site has been operated periodically since October 2006 with seasonal operation (roughly April through October) from 2008 to 2011 and continuous operation since August 2014. The downstream gaging station (06077200) has run continuously since October 1, 1996. Average monthly flows on the Smith River at the upstream gaging site range from 18 to 3200 cfs and at the downstream gaging site from 30 to 3800 cfs. The percentage of flow from Sheep Creek is unknown as there are additional tributary drainages between the two USGS gaging stations.

The Holmstrom Ditch is another significant hydrologic feature on Sheep Creek. It is a diversion ditch that was constructed by the Holmstrom Land Company in 1935 to divert Sheep Creek water for irrigation use. The diversion point to the ditch is just downstream of the former USGS-SC1 gaging station (Figure 5). While the Holmstrom Land Company continues to use the ditch for seasonal irrigation diversions, the ditch is also used by the Newlan Creek Water District as a source of water for the Newlan Reservoir.

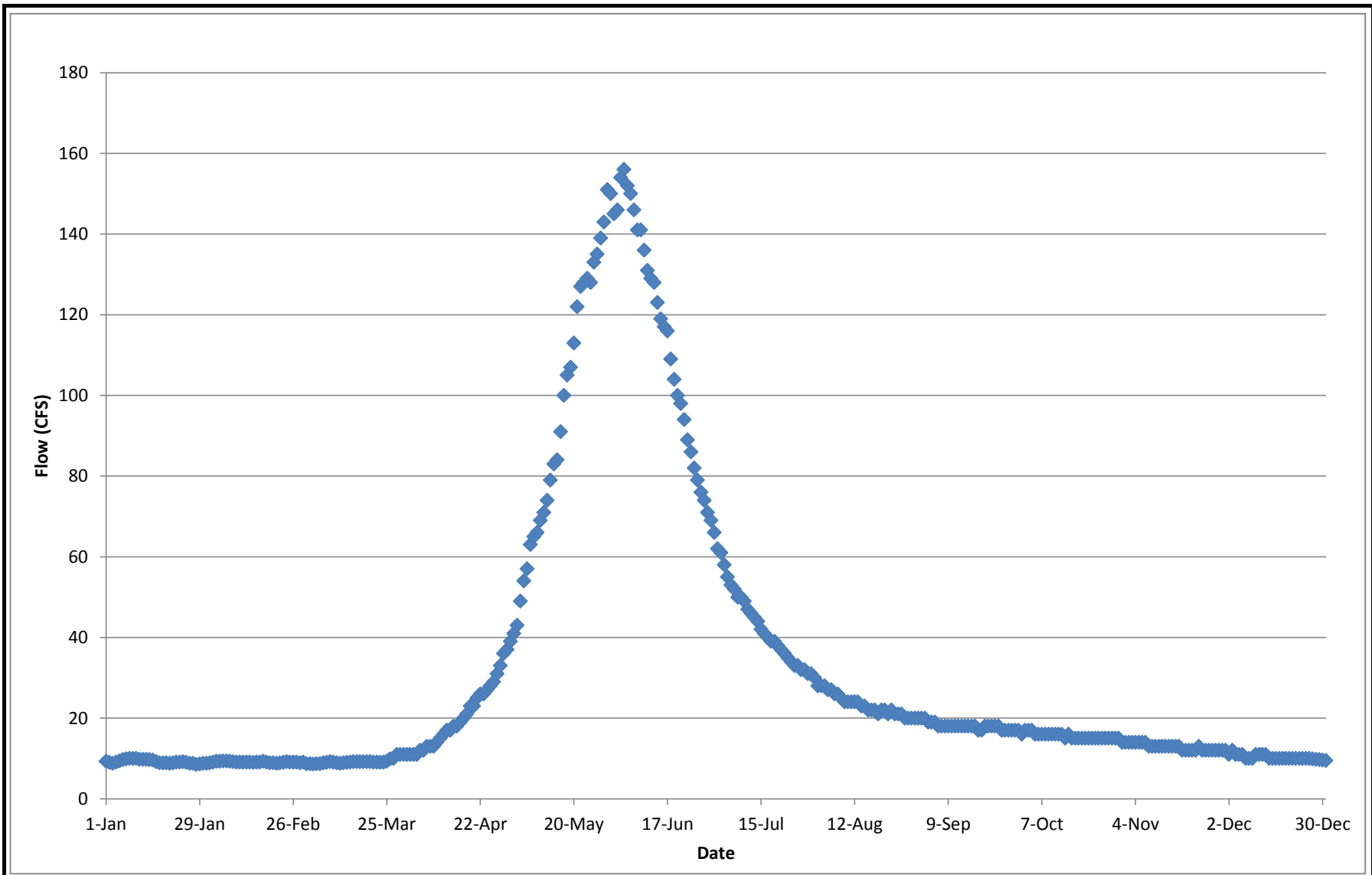

BASELINE WATER RESOURCES MONITORING AND HYDROGEOLOGIC INVESTIGATIONS RESULTS FOR THE TINTINA RESOURCES BLACK BUTTE PROJECT	MEAN DAILY FLOW HYDROGRAPH AT USGS SITE ON SHEEP CREEK	FIGURE
		6

1.1.2 Groundwater

Groundwater is present in the project area in Quaternary alluvial deposits that occupy the axes of the major drainages, in colluvium deposits and highly weathered shallow bedrock that flank these drainages, and in the underlying more competent bedrock formations. In the immediate project area, bedrock is primarily relatively low permeable dolomitic and silicic shales of the Newland Formation. A review of available information in the Groundwater Information Center (GWIC) database (Montana Bureau of Mines and Geology; MBMG) indicates wells completed in bedrock in the project area are generally low yielding with reported yields of 4 to 50 gpm (median 12 gpm). The bedrock wells within the area are generally completed at depth greater than 100 feet below ground surface (one well completed above 100 feet; range 52 to 500 feet, median 191 feet). There is limited historical information on the hydrogeology of the project area; however, artesian flow has been noted during previous exploration activities (RMI, 2010) in some exploration drill holes completed in the deeper bedrock units underlying the Sheep Creek Valley. In general, artesian flows were noted in core holes that were collared in the Sheep Creek Valley and penetrated through the VVF into the LCZ, flows were observed after the holes were left open for many weeks/months. Flow rates from these core holes were very low, and when they were observed the holes were plugged at depth to seal off the groundwater in the LCZ (Zieg, 2016).

2.0 BASELINE MONITORING

The surface water and groundwater monitoring discussed below establish baseline stream flows, groundwater potentiometric elevations, and water quality in the project area. Hydrometrics, Inc. (Hydrometrics) of Helena, MT has conducted the baseline surface water and groundwater monitoring for the Black Butte Copper Project since the sampling was initiated in 2011. Water resource monitoring is conducted in accordance with the 2013 Field Sampling and Analysis Plan (Hydrometrics, 2013b). Surface water and groundwater quality samples are submitted to Energy Laboratories in Helena, MT for analyses of physical parameters, common constituents, nutrients, and a comprehensive suite of trace constituents as listed in Tables 2 and 3, respectively. With the exception of aluminum, trace constituents are analyzed for the total recoverable fraction for surface water samples; aluminum is analyzed for the dissolved fraction. All trace constituents for groundwater samples are analyzed for the dissolved fraction. In addition to the laboratory analysis, hardness was calculated based on the concentration of calcium and magnesium. During some monitoring events bicarbonate and carbonate concentrations were reported by the laboratory, these results are included in the water quality databases (Appendix A). This report summarizes the results of groundwater and surface water monitoring conducted through July 2015.

2.1 SURFACE WATER MONITORING

Eleven surface water stations have been established as baseline monitoring sites (Figure 2). Flow, stage, and field parameters (temperature, pH, and specific conductivity (SC)) are monitored quarterly at all of these sites. Water quality samples are collected at six of the sites during quarterly monitoring. Monitoring was initiated at these sites in May 2011 with subsequent quarterly monitoring events scheduled in the months of August, November, March, and May of each year. In July 2011, surface water samples were collected from two sites (G-1 and G-2) downgradient of where gossan outcropped in the streambed to evaluate if exposed gossan affected surface water quality. This was a one-time monitoring event and these sites are not included as part of the long-term baseline monitoring program. Monthly surface water monitoring has been conducted at sites on Sheep Creek since 2014.

**TABLE 2. PARAMETERS, METHODS, AND DETECTION LIMITS FOR
BASELINE SURFACE WATER MONITORING**

Parameter	Analytical Method ⁽¹⁾	Project-Required Detection Limit (mg/L)
Physical Parameters		
TDS	SM 2540C	4
TSS	SM 2540C	4
Common Ions		
Alkalinity	SM 2320B	4
Sulfate	300.0	1
Chloride	300.0/SM 4500CL-B	1
Fluoride	A4500-F C	0.1
Calcium	215.1/200.7	1
Magnesium	242.1/200.7	1
Sodium	273.1/200.7	1
Potassium	258.1/200.7	1
Nutrients		
Nitrate+Nitrite as N	353.2	0.003
Total Persulfate Nitrogen	A 4500-N-C	0.04
Total Phosphorus	E365.1	0.003
Trace Constituents (SW - Total Recoverable except Aluminum [Diss], GW - Diss)⁽²⁾		
Aluminum (Al)	200.7/200.8	0.009
Antimony (Sb)	200.7/200.8	0.0005
Arsenic (As)	200.8/SM 3114B	0.001
Barium (Ba)	200.7/200.8	0.003
Beryllium (Be)	200.7/200.8	0.0008
Cadmium (Cd)	200.7/200.8	0.00003
Chromium (Cr)	200.7/200.8	0.01
Cobalt (Co)	200.7/200.8	0.01
Copper (Cu)	200.7/200.8	0.002
Iron (Fe)	200.7/200.8	0.02
Lead (Pb)	200.7/200.8	0.0003
Manganese (Mn)	200.7/200.8	0.005
Mercury (Hg)	245.2/245.1/200.8/SM 3112B	0.000005
Molybdenum (Mo)	200.7/200.8	0.002
Nickel (Ni)	200.7/200.8	0.001
Selenium (Se)	200.7/200.8/SM 3114B	0.0002
Silver (Ag)	200.7/200.8	0.02
Strontium (Sr)	200.7/200.8	0.0002
Thallium (Tl)	200.7/200.8	0.0002
Uranium	200.7/200.8	0.008
Zinc (Zn)	200.7/200.8	0.002
Field Parameters		
Stream Flow	HF-SOP-37/-44/-46	NA
Water Temperature	HF-SOP-20	0.1 °C
Dissolved Oxygen (DO)	HF-SOP-22	0.1 mg/L
pH	HF-SOP-20	0.1 s.u.
Specific Conductance (SC)	HF-SOP-79	1 µmhos/cm

(1) Analytical methods are from *Standard Methods for the Examination of Water and Wastewater* (SM) or EPA's *Methods for Chemical Analysis of Water and Waste* (1983).

(2) Samples to be analyzed for dissolved constituents will be field-filtered through a 0.45 µm filter.

**TABLE 3. PARAMETERS, METHODS, AND DETECTION LIMITS FOR
BASELINE GROUNDWATER MONITORING**

Parameter	Analytical Method⁽¹⁾	Project-Required Detection Limit (mg/L)
Physical Parameters		
TDS	SM 2540C	10
TSS	SM 2540C	10
Common Ions		
Alkalinity	SM 2320B	4
Sulfate	300.0	1
Chloride	300.0/SM 4500CL-B	1
Fluoride	A4500-F C	0.1
Calcium	215.1/200.7	1
Magnesium	242.1/200.7	1
Sodium	273.1/200.7	1
Potassium	258.1/200.7	1
Nutrients		
Nitrate+Nitrite as N	353.2	0.01
Trace Constituents (Dissolved)⁽²⁾		
Aluminum (Al)	200.7/200.8	0.009
Antimony (Sb)	200.7/200.8	0.0005
Arsenic (As)	200.8/SM 3114B	0.001
Barium (Ba)	200.7/200.8	0.003
Beryllium (Be)	200.7/200.8	0.0008
Cadmium (Cd)	200.7/200.8	0.00003
Chromium (Cr)	200.7/200.8	0.01
Cobalt (Co)	200.7/200.8	0.01
Copper (Cu)	200.7/200.8	0.002
Iron (Fe)	200.7/200.8	0.02
Lead (Pb)	200.7/200.8	0.0003
Manganese (Mn)	200.7/200.8	0.005
Mercury (Hg)	245.2/245.1/200.8/SM 3112B	0.000005
Molybdenum (Mo)	200.7/200.8	0.002
Nickel (Ni)	200.7/200.8	0.001
Selenium (Se)	200.7/200.8/SM 3114B	0.0002
Silver (Ag)	200.7/200.8	0.02
Strontium (Sr)	200.7/200.8	0.0002
Thallium (Tl)	200.7/200.8	0.0002
Uranium	200.7/200.8	0.008
Zinc (Zn)	200.7/200.8	0.002
Field Parameters		
Stream Flow	HF-SOP-37/-44/-46	NA
Water Temperature	HF-SOP-20	0.1 °C
Dissolved Oxygen (DO)	HF-SOP-22	0.1 mg/L
pH	HF-SOP-20	0.1 s.u.
Specific Conductance (SC)	HF-SOP-79	1 µmhos/cm

(1) Analytical methods are from *Standard Methods for the Examination of Water and Wastewater* (SM) or EPA's *Methods for Chemical Analysis of Water and Waste* (1983).

(2) Samples to be analyzed for dissolved constituents will be field-filtered through a 0.45 µm filter.

2.1.1 Stream Flows

Seasonal flow measurements have been taken at Sheep Creek upstream of the project area (SW-2) and downstream (SW-1) since baseline monitoring was initiated in May 2011. High flow season (May/June) stream flows are difficult to accurately measure in Sheep Creek due to water depths and high flow velocities, but estimated flows during May/June quarterly sampling rounds on Sheep Creek have ranged from approximately 100 cfs up to 600 cfs. In contrast, baseflows in late summer/fall monitoring events have ranged from 10 to 30 cfs at upstream monitoring site SW-2 and 15 to 34 cfs at downstream monitoring site SW-1. Flow measurements typically increase by 25% to 50% from SW-2 to SW-1. In addition to the flow monitoring at baseline monitoring sites, stream flow has also been measured monthly at the former upstream USGS gaging site since May 2014 with concurrent measurements at SW-1 and SW-2 to allow correlation of the stream flows between the sites. A comparison of stream flow monitoring results is shown in Figure 7. Streamflow increases between the upstream USGS-SC1 site and downstream SW-1 by a factor of up to 2.5 during spring runoff and then gradually decreases becoming nearly equal in late August when tributary inflows downstream of USGS-SC1 are diverted for irrigation. Downstream flows increase after irrigation season ends and the flow measurements show approximately 50% increase in streamflow between USGS-SC-1 and SW-1 during baseflow periods in early spring.

In November 2012, Tintina installed a temporary stilling well with a transducer to develop detailed seasonal baseline data on water level stage and discharge fluctuations in Sheep Creek. The stilling well is located at monitoring site SW-1 and is just north of the location where Sheep Creek enters the narrow bedrock canyon below the project site. It is identified as the Sheep Creek Gaging Station on Figure 2. Baseline stage and flow measurements from SW-1 were used to generate a stage/discharge rating curve for the Sheep Creek Gaging station that allow water level records from the gauging stations to be converted to stream flows (Figure 8). The SW-1 hydrograph presented on Figure 9 shows seasonal streamflows in excess of 100 cfs extending from mid-May-through mid-June in Sheep Creek with peak flows of 200 cfs to over 800 cfs. Stream flows in Sheep Creek decline rapidly in late June/early July with average monthly flows of 15 cfs to 30 cfs by late summer. By late

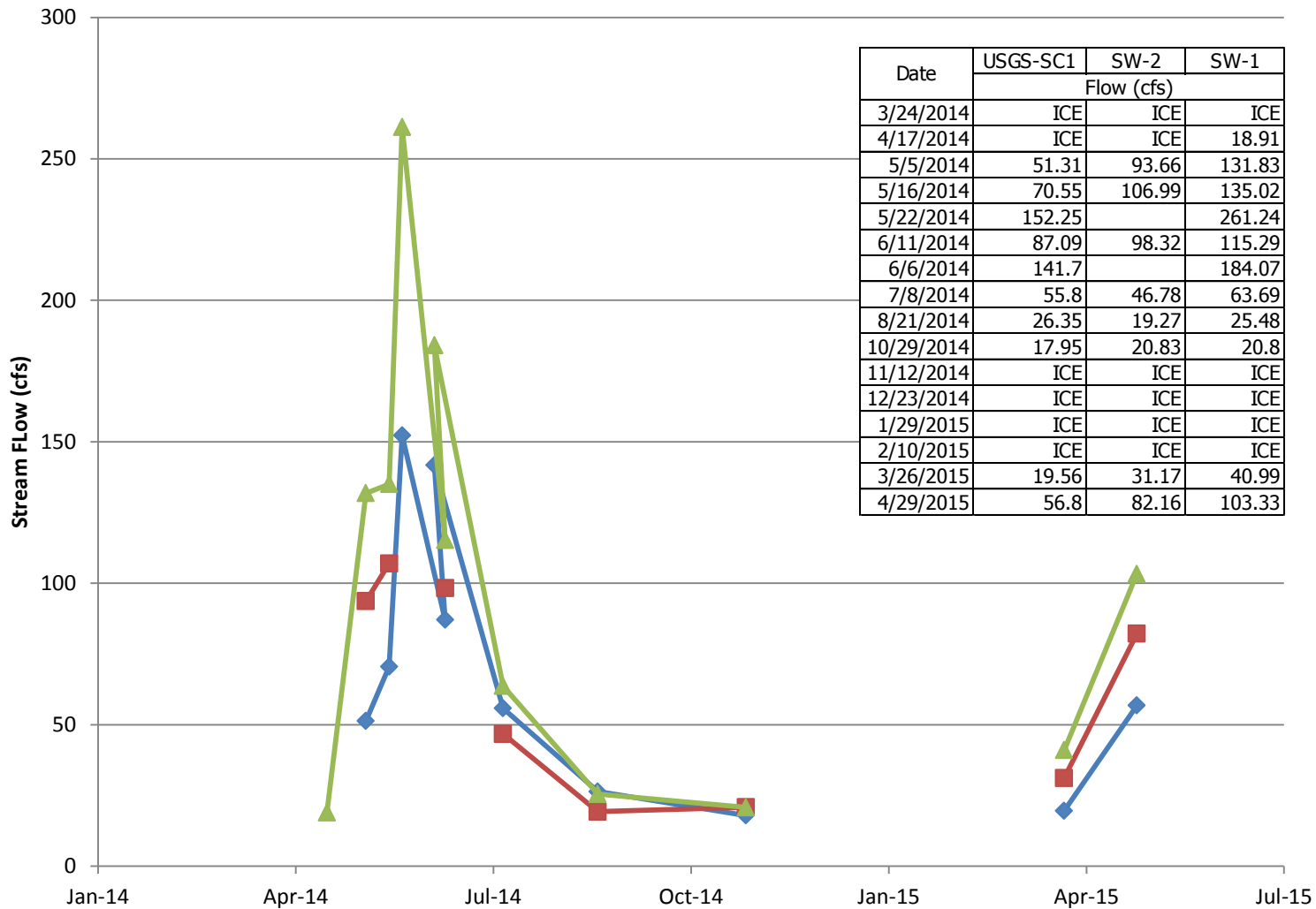

◆ USGS-SC1
■ SW-2
▲ SW-1

**BASELINE WATER RESOURCES MONITORING AND
 HYDROGEOLOGIC INVESTIGATIONS RESULTS FOR THE
 TINTINA RESOURCES BLACK BUTTE PROJECT**

**STREAMFLOW COMPARISON AT
 SHEEP CREEK MONITORING SITES**

FIGURE

7

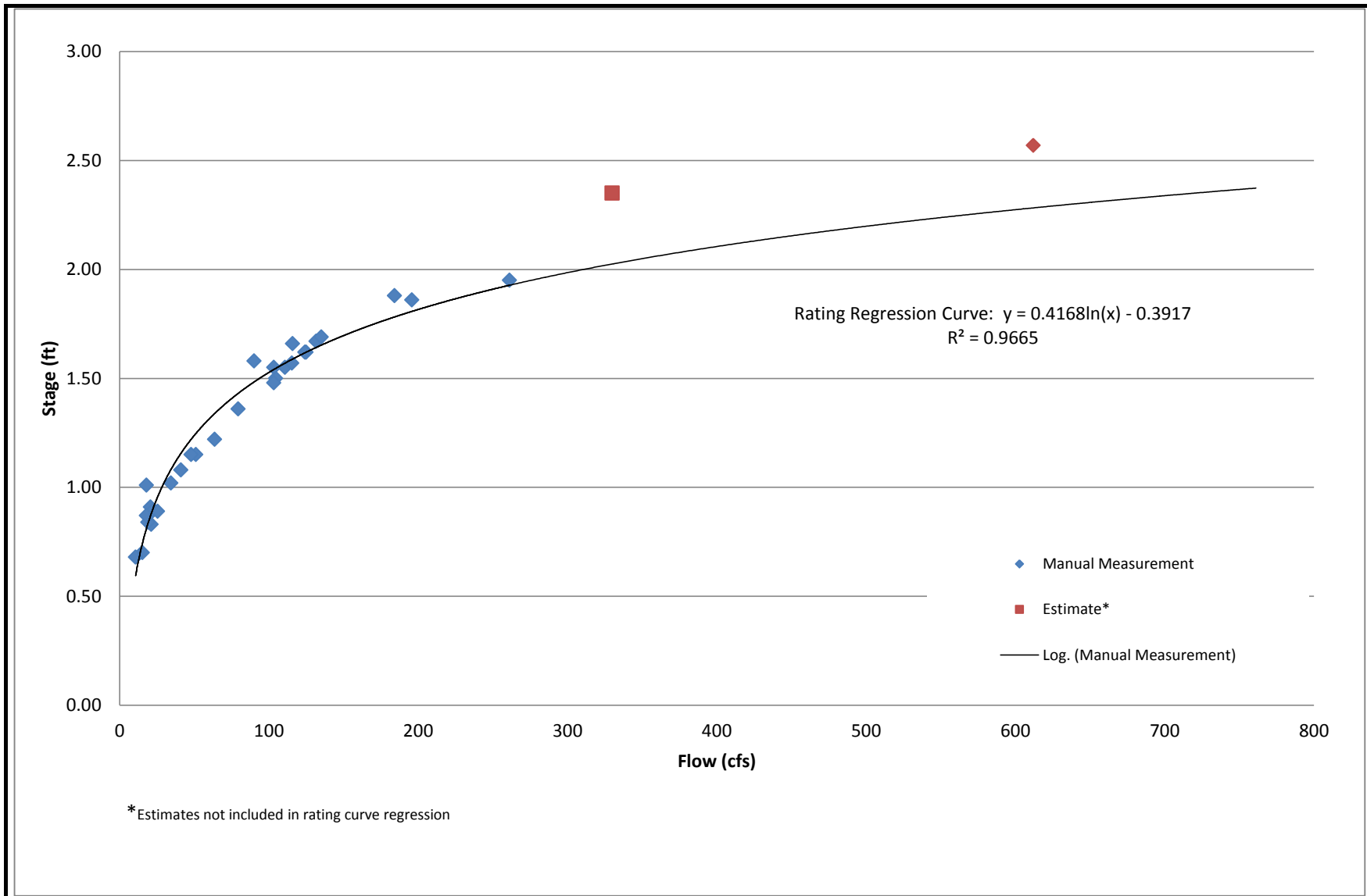

BASELINE WATER RESOURCES MONITORING AND HYDROGEOLOGIC INVESTIGATIONS RESULTS FOR THE TINTINA RESOURCES BLACK BUTTE PROJECT	RATING CURVE OF SW-1 SHEEP CREEK MONITORING SITE	FIGURE
		8

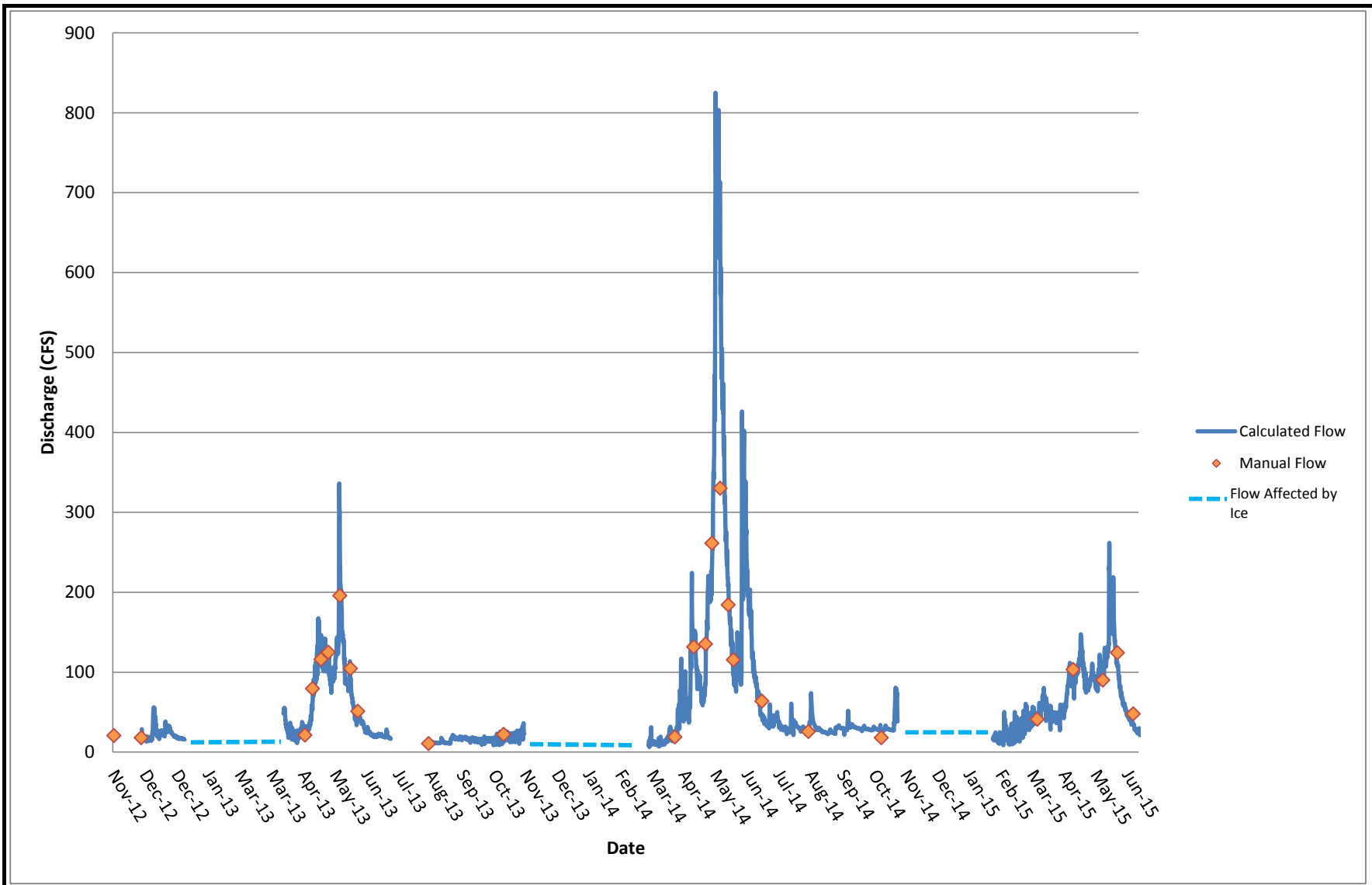

**BASELINE WATER RESOURCES MONITORING AND
HYDROGEOLOGIC INVESTIGATIONS RESULTS FOR THE
TINTINA RESOURCES BLACK BUTTE PROJECT**

**HYDROGRAPH OF SW-1 SHEEP CREEK
MONITORING SITE**

**FIGURE
9**

winter, gauging data indicate steady state base flow in Sheep Creek is approximately 15 cfs at SW-1.

Flow monitoring results for each of the surface water monitoring sites is summarized in Table 4, and stream flow data for each of the sites is tabulated in the monitoring database in Appendix A.

TABLE 4. SUMMARY OF STREAM FLOW MONITORING DATA

Monitoring Station	Stream	March	May/June	August/Nov
		Measured Stream Flow (cfs)		
SW-1	Sheep Ck	30-41	111-613	10-34
SW-2	Sheep Ck	Frozen	98-250	7-30
SW-3	Coon Ck	0.22	0.3-5	0.08-0.34
SW-4	Coon Ck	0.16	0.2-2	0.01-0.4
SW-6	Unnamed tributary to Black Butte Ck	0.04-0.26	0.5-4	0.17-0.33
SW-7	Unnamed tributary to Black Butte Ck	0-0.4	0-0.3	0.001-0.01
SW-8	Little Sheep Ck	1.7	1-9	0.2-1
SW-9	Black Butte Ck	0.3-1.8	2.3-12.7	0.3-0.8
SW-10	Black Butte Ck	Frozen	1.7-15.2	0.3-0.5
SW-11	Black Butte Ck	1.0-2.9	1.6-21.4	0.4-1.0

The observed increase in stream flow in Sheep Creek between SW-2 and SW-1 appears to be largely accounted for during high flow season by inflow from Little Sheep Creek; however, during baseflow periods the increase is not entirely accounted for by Little Sheep Creek or other monitored tributaries. The increase is likely attributable to groundwater discharge and/or inflow from unmonitored springs and tributaries on Castle Mountain property to the north of Sheep Creek.

2.1.2 Surface Water Quality

Water quality data for each of the surface water monitoring sites is presented in Appendix A and water quality statistics for individual sites are compiled in Appendix B. Surface water results show neutral to slightly alkaline pH values (6.8 to 8.6), and low to moderate specific

conductance (49 to 487 $\mu\text{mhos/cm}$). A few lower field pH readings (5.3 to 6.4) were reported at SW-1 during winter sampling events. Spot checks of pH at the lab indicated sample pHs above 8, which is consistent with readings from other sampling rounds at this site and with data from SW-2 and USGS-SC1. Discussions with the instrument manufacturer verified that the probe is susceptible to error at low temperatures; therefore, these results have been flagged as anomalous in the database (Appendix A).

Major ion chemistry is dominated by calcium and bicarbonate. With the exception of SW-5, which only has flow during spring runoff, hardness ranges from approximately 73 to 256 mg/L. Metals data show some infrequent excursions above DEQ-7 water quality standards for selected metals (aluminum and iron) during high runoff events. Samples collected from gossan sites G-1 and G-2 were similar to the long-term water quality monitoring sites and therefore they were not added to the long-term baseline water resource monitoring program. Surface water standard exceedances were observed for the following constituents:

- Chronic aquatic criteria for total recoverable iron (1 mg/L) is exceeded during peak runoff periods at all sites except SW-6 and SW-11 (2011) and SW-3 (2012).
- Chronic aquatic criteria for dissolved aluminum (0.087 mg/L) is often exceeded during periods of high runoff in Sheep Creek (SW-1, SW-2, and USGS SC-1) and in Black Butte Creek (SW-11).
- In addition, the human health surface water standard for thallium of 0.00024 mg/L was exceeded at SW-3 during three separate monitoring events in 2011.

The iron and aluminum exceedances are likely related to increased turbidity during periods of snowmelt and high runoff.

2.2 GROUNDWATER

2.2.1 Geology/Hydrostratigraphy

The geology and subsurface stratigraphy within the project area has been evaluated based on geologic mapping and extensive exploratory drilling. A geologic map of the project area is

shown in Figure 10 and a geologic cross section through the project area is shown in Figure 11. Alluvial deposits are present beneath the stream channels and along the axis of the drainages. The mine will penetrate a thick sequence of dolomitic and silicic shales of the Proterozoic Newland Formation that dips gently to the southeast in the project area.

The project area is bounded to the north by a prominent northeast trending thrust fault known as the Volcano Valley Fault (VVF). Paleozoic Flathead sandstone is exposed at the surface on the north side of the VVF and lies unconformably over Proterozoic Chamberlain shales, Neihart quartzite and Precambrian crystalline basement rock (Figure 11). A separate northeast verging segment of the VVF thrust fault called the Black Butte Fault (BBF) is located south of the ore body (Figure 10). The area between the Black Butte fault and the VVF contains all of the known copper resources within the Project area.

Figure 12 shows the principal stratigraphic units that will be encountered during development of the Johnny Lee deposits. There are upper (UCZ) and lower (LCZ) ore zones within the Johnny Lee copper-cobalt deposit hosted within the Upper and Lower Sulfide Zones (USZ, LSZ) of the lower Newland Formation. The upper ore zone lies at a depth of approximately 250 to 350 feet below ground surface and is overlain by shale and dolostone (Ynl A), and dolomite (Ynl O) interbeds. The upper ore zone is underlain by the lower Newland shale and conglomerate (Ynl B). These units are cut by the southward dipping VVF to the north. A thin slice of the lower Newland Formation lies below the VVF and contains the lower ore zone, which is at a depth of approximately 1,300 to 1,500 feet below groundwater surface. The Lower Ore Zone and Lower Newland shales are just above the contact with the Chamberlain Formation and are cut to the north by the Buttress Fault, a Precambrian normal fault (Figure 11). The Buttress fault does not extend to the surface but is truncated by the VVF (Figure 11) and therefore does not have a surface expression on the geologic map in Figure 10.

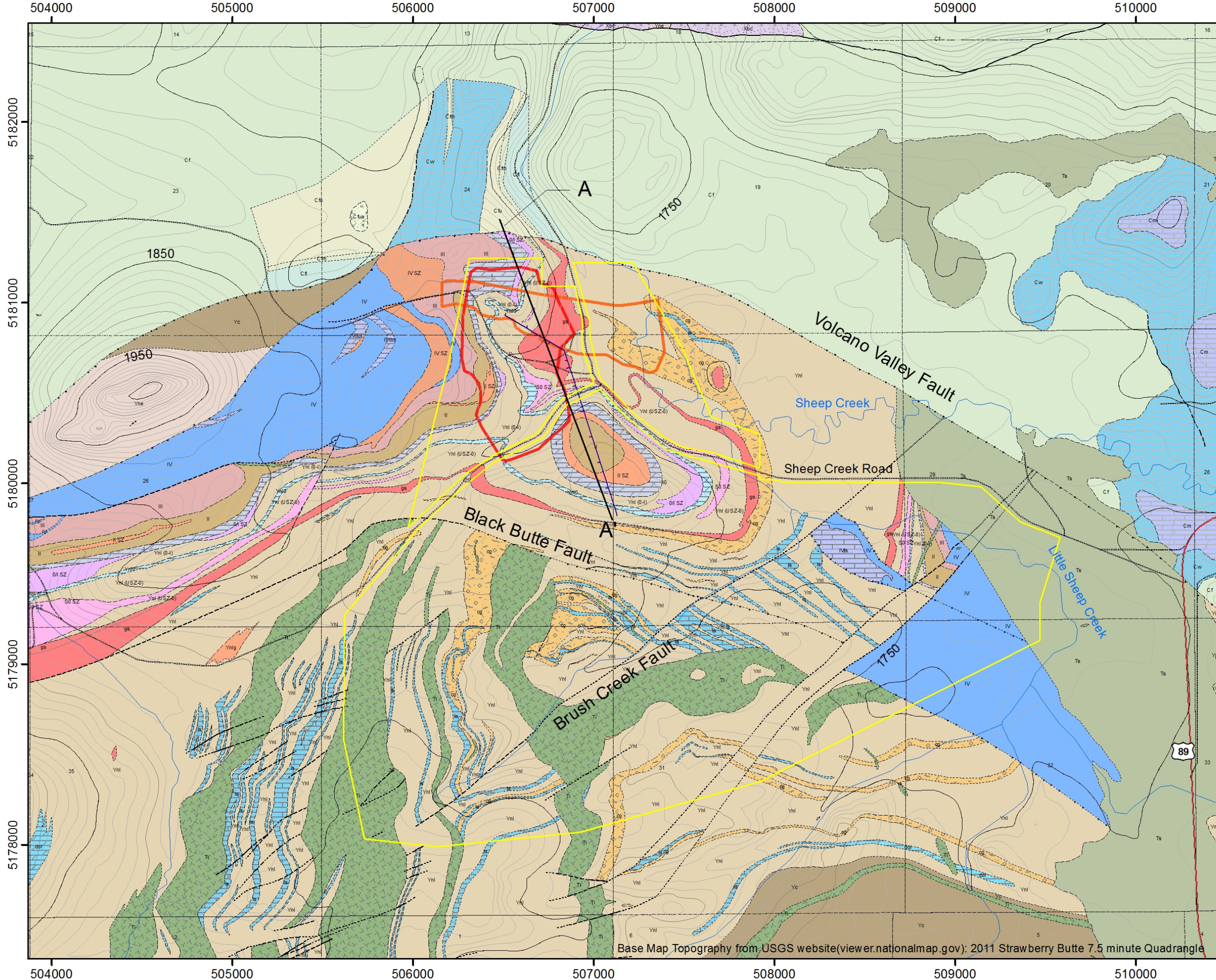

Legend

- Contact - Defined (solid line)
- Contact - Approximate (dashed line)
- Contact - Inferred (dotted line)
- Fault - Defined (thick solid line)
- Fault - Approximate (thick dashed line)
- Fault - Questionable (thick dotted line)
- Fault - Inferred (thin dashed line)
- Fault - Buried (dotted line with triangles)
- Thrust - Defined (thick solid line with triangles)
- Thrust - Approximate (thick dashed line with triangles)
- Thrust - Inferred (thin dashed line with triangles)
- Thrust - Questionable (thick dashed line with triangles)
- Mine Permit Boundary (yellow outline)
- Decline (blue line)
- Stream / River (blue line)
- Dirt (dotted line)
- Gravel Maintained (dashed line)
- Highway (red line)
- Jeep Trail (dotted line)

Black Butte Lithologies

Tertiary	Upper Newland
Tertiary Basalt (Tb)	Siliceous Gossan (sig)
Tertiary Sediments (Ts)	VII
Tertiary Igneous (Ti)	VI
	V
Paleozoic	IV Dolostone
Lodgepole (MI)	IV Limestone
Madison (Mm)	IV Silt
Three Forks (MDT)	IV
Jefferson (Dj)	IV SZ
Meagher (DCm)	III
Park (Cp)	II SZ
Wolsey (Cw)	II
Meagher (Cm)	I
Pilgrim (Cpi)	Jasper (j)
Up. Flathead-arkose (Cfua)	Up. Newland Undiff. (Ynu)
Upper Flathead (Cfu)	
Middle Flathead (Cfm)	
Flathead Sandstone (Cf)	
Lower Flathead (Cfl)	
Helena Embayment (non-Newland)	Lower Newland
Greyson Shale (Yg)	Ynl (0-1)
Neihart Quartzite (Yne)	0I SZ
Chamberlain Shale (Yc)	Ynl0
Spokane Shale (Ys)	Ynl (USZ-0)
	gs (gossan)
Metamorphic Basement	Sub 0 SZ
Undiff. (Xbc)	Low. Newland Shale (Ynl)
	Low. Newland Chert (Ynlch)
	Low. Newland Qtzt (Ynlq)
	Gossan Undiff. (Ynlgs)
	Dolostone (dol)
	Limestone (ls)
	MS Conglomerate (ms-cg)
	Conglomerate (cg)

NOTE: All of the sulfide zone (SZ) lithologic units in the Newland Formation are oxidized to gossan in the near surface environment.

UCZ Johnny Lee Deposit Upper Zone (UCZ)
LCZ Johnny Lee Deposit Lower Zone (LCZ)
 *boundaries projected to surface

WGS 1984, UTM Zone 12N
 Contour Interval 10 meters

0 250 500 1,000 Meters
 0 500 1,000 2,000 3,000 4,000 Feet

TINTINA RESOURCES

Figure 10
 Site Geologic Map Showing Copper-Rich Deposits
 Black Butte Copper Project, Meagher County, MT

Base Map Topography from USGS website(viewer.nationalmap.gov): 2011 Strawberry Butte 7.5 minute Quadrangle

K:\Project\11048\Baseline WRM Report\Revised June2016\Figures\Figure11_Generalized XSection.srf

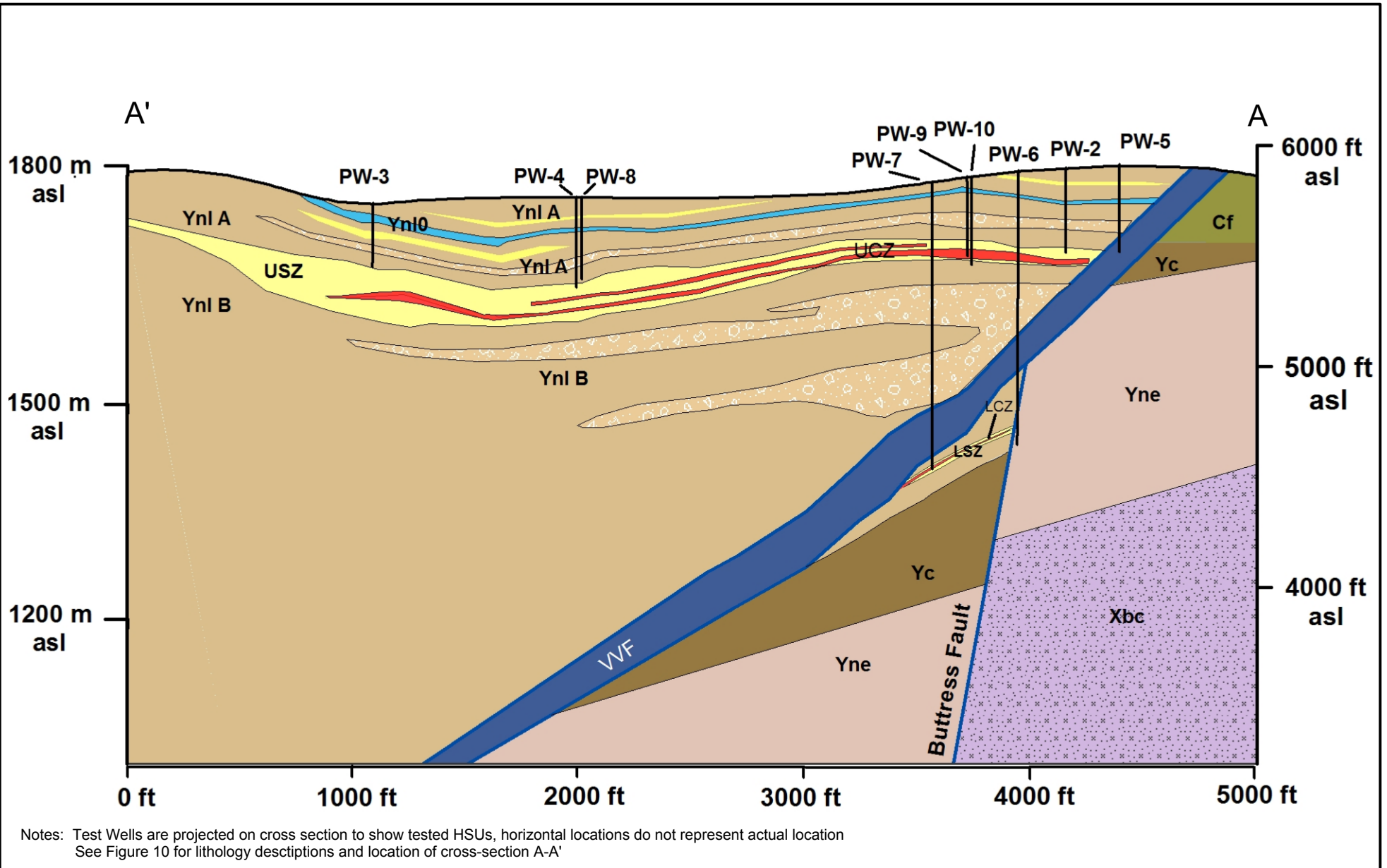

Notes: Test Wells are projected on cross section to show tested HSUs, horizontal locations do not represent actual location
See Figure 10 for lithology descriptions and location of cross-section A-A'

Prepared by Tintina Montana



Figure 11
Generalized Cross-Section with Well Locations
BLACK BUTTE COPPER PROJECT
Meagher County, Montana

FIGURE 12. SCHEMATIC DIAGRAM OF HYDROSTRATIGRAPHIC UNITS AND ASSOCIATED WELL COMPLETIONS

Unit	Monitoring Well Completion		Test Well Completions	
Qa/Overburden	MW-1A, MW-6A, MW-4A			
Ynl-0 Dolostone	MW-6B, MW-7, MW-8	MW-1B, MW-2A,	PW-1, PW-3 PW-8	PW-5 Volcano Valley Fault
Ynl-A	MW-9,	MW-2B		
USZ	MW-3		PW-2, PW-4	
UCZ			PW-9	
Ynl-B	MW-4B		PW-10	
LCZ			PW-7	PW-6 Buttress Fault
Yne			PW-6N	

Monitoring wells and test wells have been completed within the shallow and deep stratigraphic units described above to define baseline water levels, groundwater flow directions and groundwater quality within the project area. A series of paired monitoring wells (MW-1A,-1B, MW-2A, -2B, MW-4A, -4B, and MW-6A, -6B) were installed between 2011 and 2013 to document baseline conditions within the unconsolidated Quaternary/Tertiary clayey gravel deposits and in the underlying shallow bedrock groundwater system (Figure 3). Monitoring well MW-3 was completed in November 2011 near the proposed terminus of the exploration decline within the UCZ. Paired wells MW-6A and MW-6B and two single wells (MW-7 and MW-8) were completed as groundwater quality and water level monitoring wells to document baseline water quality in the vicinity of the proposed underground LAD/infiltration system where treated mine water will be discharged. MW-6A is completed in shallow alluvial gravels, and MW-6B, MW-7, and

MW-8 are completed in shallow YNL-0 dolostone bedrock. In 2014, an additional monitoring well, MW-9, was installed in the YNL-A zone above the sulfide and ore zones as a monitoring point to assess the effects of ore zone dewatering on overlying units during mine development.

In addition to these monitoring wells, 10 test wells (PW-1 through PW-10) have been installed for aquifer testing to provide information on both the hydrologic characteristics and water quality within representative stratigraphic units. A schematic diagram depicting completion units for all of the monitoring and test wells is shown in Figure 10. Water level and water quality data have been collected at the PW series test wells during aquifer testing; however, the test wells are not routinely monitored during quarterly baseline monitoring events. Well completion data for all of the monitoring wells and test wells is summarized in Table 5, water quality data is included in Appendix A and water quality statistics for individual sites are compiled in Appendix B. Well logs are included in Appendix C.

Twelve piezometers are used to monitor the groundwater levels in the alluvial/colluvial systems of Sheep Creek, Coon Creek, and Dry Creek. Piezometers PZ-1 through PZ-5, PZ-8, PZ-9, and PZ-11 are completed in the Sheep Creek alluvial system. Paired piezometers PZ-7A/-7B are located near the headwaters of Coon Creek and PZ-12 located near MW-3 adjacent to Coon Creek. PZ-12 is located in the Dry Creek drainage south of wells MW-9, PW-9, and PW-10. The completion details of each piezometer are included in Table 5.

2.2.2 Groundwater Flow Directions

Water level data from the November 2014 sampling round are compiled in Figure 13; the potentiometric surface shows an eastward trending flow direction in the bedrock groundwater system within the project area that is consistent with the general topographic trend in the area. The potentiometric contours of the bedrock hydrologic system indicate an average hydraulic gradient of approximately 0.08. Groundwater in the Sheep Creek alluvium generally flows parallel to the creek; northwest and then turns to the north as Sheep Creek

Table 5. Well Completion Data

Well Name	Northing (meters)	Easting (meters)	Ground Surface Elev.	Measuring Point Elev.	Borehole Total Depth	Well Total Depth	Screen Interval	Hydro-stratigraphic Unit	Year Drilled	Purpose
			(feet, amsl)							
UTM Zone 12 North										
Monitoring Wells										
MW-1A	5180841.55	506935.22	5635.81	5637.73	38	34	25 - 34	Overburden	2011	Baseline
MW-1B	5180845.46	506934.19	5636.14	5637.90	98	98	88 - 98	YNL-A		East of USZ
MW-2A	5180331.93	506598.18	5743.72	5745.31	62	62	52 - 62	Shallow Bedrock	2011	Baseline East of Coon Creek
MW-2B	5180328.73	506596.96	5743.44	5745.53	80	80	70 - 80	YNL-A		Baseline USZ
MW-3	5180740.22	506484.07	5760.06	5762.17	305	305	285 - 305	USZ	2011	Baseline Sheep Cr. Alluvium
MW-4A	5180855.43	507201.47	5610.12	5612.12	23	23	14-23	Sheep Creek Alluvium	2012	Baseline YNL-A below Sheep Cr. Alluvium
MW-4B	5180858.49	507200.12	5610.07	5612.07	59	59	39-59	YNL-A	2012	
MW-5	Not Drilled									
MW-6A	5179492.85	507809.18	5680.08	5681.87	20	15	5-15	Quaternary	2013	
MW-6B	5179490.71	507792.76	5683.41	5685.31	50	50	40-50	Dolostone	2013	Proposed UG LAD
MW-7	5179500.71	507451.70	5747.48	5749.46	50	50	40-50	Dolostone	2013	Proposed UG LAD
MW-8	5179398.31	507036.00	5809.10	5810.93	80	80	70-80	Dolostone	2013	Proposed UG LAD
MW-9	5180725.46	506592.96	5744.35	5745.80	144	128	108-128	YNL-A	2014	Baseline YNL-A Characterization
Test Wells										
PW-1	5180698.40	506301.42	5912.07	5913.74	213	211	140-211	YNL-A - Perched	2011	Previous Decline
PW-2	5180865.03	506443.15	5793.08	5794.88	215	212	132 - 212	USZ	2011	Previous Decline
PW-3	5180479.42	506846.43	5655.21	5657.42	131	127	90-127	YNL-A	2012	Expl Decline
PW-4	5180701.75	506849.44	5678.13	5680.01	242	239	200-239	USZ	2012	Expl Decline
PW-5	5181172.77	506490.68	5913.22	5915.49	555	500	515-555	Volcano Valley Fault	2013	Volcano Valley Fault Hydrologic Characteristics
PW-6	5181085.67	506477.44	5895.43	5897.40	1234	1204	1164-1204	Buttress Fault	2013	Buttress Fault Hydrologic Characteristics
PW-6N	5181085.67	506477.44	5895.43	5897.40	1358	1358	Open Borehole 1234-1358	Niehart Quartzite	2015	Baseline YNE Hydrologic Characterization
PW-7	5180867.59	507122.89	5609.11	5611.15	1350	1346	1306-1346	LCZ	2013	Baseline LCZ Characterization
PW-8	5180695.53	506846.19	5679.12	5680.60	184	178.5	138.5-178.5	YNL-A	2014	Baseline YNL-A Characterization
PW-9	5180721.88	506598.38	5743.59	5745.05	255.5	255.5	215.5-255.5	UCZ	2014	Baseline UCZ Characterization
PW-10	5180721.88	506593.55	5743.57	5744.84	369.5	358.5	318.5-358.5	YNL-B	2014	Baseline YNL-B Characterization
SC15-184*	507047	5178973	5747	5747	99	85	55-85	Granodiorite	2015	Project Facilities Baseline Characterization
SC15-185*	506355	5179094	5917	5917	99	80	60-80	Granodiorite	2015	Project Facilities Baseline Characterization
SC15-194*	506014	5179855	5878	5878	99	80	60-80	YNL-A	2015	Project Facilities Baseline Characterization
SC15-198*	506621	5179762	5815	5815	99	70	60-70	YNL-A	2015	Project Facilities Baseline Characterization
Piezometers										
PZ-01	5180256	507650	5628.69	5630.34	NA	5.3	2.3-5.3	Alluvium	2012	Alluvium Water Level Monitoring
PZ-02	5180779	507401	5611.81	5613.51	NA	5.3	2.3-5.3	Alluvium	2012	Alluvium Water Level Monitoring
PZ-03	5180619	507249	5616.08	5616.08	NA	9.3	6.3-9.3	Alluvium	2012	Alluvium Water Level Monitoring
PZ-04	5181111	506991.74	5599.34	5602.7	NA	7.7	4.7-7.7	Alluvium	2012	Alluvium Water Level Monitoring
PZ-05	5181215	507080	5598.16	5599.79	NA	5.4	2.4-5.4	Alluvium	2012	Alluvium Water Level Monitoring
PZ-07A	5180075	506258	5776.57	5777.5	NA	6	3-6	Alluvium	2014	Alluvium Water Level Monitoring
PZ-07B	5180075	506258	5776.57	5777.59	NA	11	8-11	Alluvium	2014	Alluvium Water Level Monitoring
PZ-08	5180574	507090	5618.9	5621.29	NA	12	7-12	Alluvium	2014	Alluvium Water Level Monitoring
PZ-09	5180179	507884	5634.73	5637.27	NA	10	5-10	Alluvium	2014	Alluvium Water Level Monitoring
PZ-10	5180679	506591	5723.51	5727.42	NA	11	9-11	Alluvium	2014	Alluvium Water Level Monitoring
PZ-11	5180655	507031	5618.77	5622.24	NA	11	9-11	Alluvium	2014	Alluvium Water Level Monitoring
PZ-12	5180509	506839	5644.56	5646.55	NA	7	5-7	Alluvium	2014	Alluvium Water Level Monitoring

*Northings, Eastings, and elevations are approximate

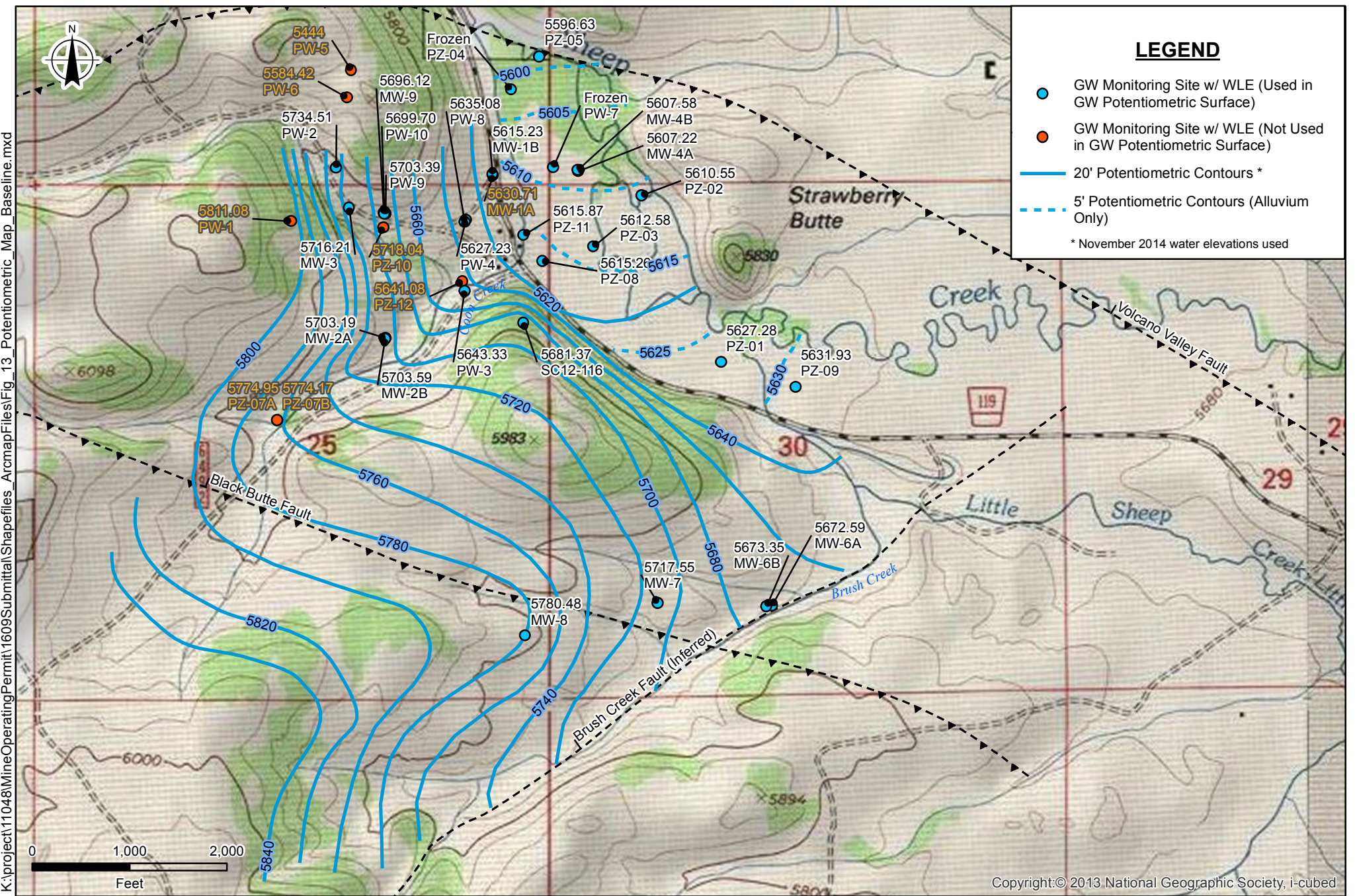

K:\project\11048\MineOperatingPermit\1609Submittal\Shapefiles_ArcmapFiles\Fig_13_Potentiometric_Map_Baseline.mxd

Copyright © 2013 National Geographic Society, i-cubed

Figure 13
Potentiometric Surface Map
Black Butte Copper Project
Meagher County, Montana

bends to the north around Strawberry Butte (Figure 13). The groundwater flow continues to flow north towards Sheep Creek as the creek crosses the northern extents of the alluvial system as it enters a small canyon. The hydraulic gradient in the alluvial system is relatively flat (0.008) through most of the monitoring area; the gradient increases slightly to 0.013 in the northern portion of the valley. Water level elevations at PZ-04 and PZ-05 (located in the northern portion of the alluvial valley) are typically near or above the ground surface throughout the year. The increased gradient and near surface water level elevations in this area are a potential indicator that the alluvial groundwater system is discharging to surface water as the alluvium pinches out where Sheep Creek flows into a canyon.

With the exception of two well pairs, most sites show upward hydraulic gradients. Paired wells MW-1A and MW-1B completed in the highly weathered shallow bedrock and the deeper more competent bedrock have a strong downward hydraulic gradient during all monitoring events with a head differential between the two wells of 15 to 18 feet indicating a shallow perched groundwater system. PZ-07A and PZ-07B also have a downward hydraulic gradient indicating that the surficial groundwater system associated with the headwaters of Coon Creek is also likely a perched system that is not fed by the deeper bedrock aquifer in this area.

In contrast, other well pairs (MW-2A/2B, MW-4A/4B, and MW-6A/6B) all show upward hydraulic gradients. Paired wells MW-2A and MW-2B, show an upward hydraulic gradient between the YNL-A groundwater system and the shallower highly weathered bedrock system with a head difference of 0.30 feet. Paired wells MW-4A and MW-4B show an upward hydraulic gradient between the bedrock aquifer and the Sheep Creek alluvium. Paired wells MW-6A and MW-6B adjacent to Brush Creek also show an upward gradient with a head difference of 0.76 feet between the shallow YNL-0 dolomitic shale and the overlying colluvium/alluvial system adjacent to Brush Creek. Artesian conditions at well PW-7 also indicate an upward hydraulic gradient in this area.

In addition to the paired wells discussed above, there is one set of triplet wells on site, MW-9, PW-9, and PW-10, which are completed in the YNL-A, UCZ, and YNL-B,

respectively. The May 2015 water levels elevations at these wells show a large upward gradient from the UCZ (PW-9) to the overlying YNL-A (with a head difference of 7.27 feet) and a large downward gradient to the underlying YNL-B (with a head difference of 3.69 feet).

2.2.3 Groundwater Quality

Field data and analytical water quality results for groundwater monitoring sites are included in Appendix A. Groundwater in the shallow alluvial wells and in shallow bedrock wells is calcium/magnesium bicarbonate type water with near neutral pH and moderately low dissolved solids. One exception is well MW-1B, which has calcium/magnesium sulfate type water with a lower pH range (6.02 to 6.51 s.u.) and moderate dissolved solids (336 to 425 mg/L). The water quality at MW-1B is similar to MW-3 and test well PW-4, both of which are completed in the sulfide ore zone.

Wells completed in shallow unconsolidated overburden include MW-1A, MW-4A, and MW-6A. These wells have neutral pH water (6.24 to 7.66 s.u.) with low to non-detectable concentrations of dissolved metals. MW-1A, however, periodically exhibits variable water quality with some excursions of arsenic, barium, iron, lead, manganese, and thallium above the Human Health standards. Well MW-1A is screened in fine-grained sediments and has very high turbidity present in the water during sampling events. Monitoring events where metals are detected at higher concentrations at this well may reflect breakthrough of particulate through the filters due to the very high turbidity.

Wells completed in bedrock above the sulfide ore zone include MW-2A and MW-2B, MW-4B, MW-6B, MW-7, MW-8, MW-9, and test wells PW-1, PW-2, and PW-3. Dissolved trace constituents that are present at detectable concentrations in the shallow bedrock wells include arsenic, barium, iron, manganese, strontium, thallium, and uranium. Water quality at test wells PW-1, PW-2, and PW-3 exceed the secondary drinking water standards for iron (0.3 mg/L) and manganese (0.05 mg/L) (neither of these secondary standards are currently listed numeric water quality standards in Montana's October 2012 Circular DEQ-7), and the concentration of thallium at MW-2B (0.0024-0.004 mg/L) was at or exceeds the human

health standard of 0.00024 mg/L. Thallium concentrations at the other shallow bedrock wells are below regulatory limits. All other parameters in the shallow aquifer meet applicable regulatory limits.

While thallium is also present at detectable concentrations in MW-3 and PW-4, it does not exceed the human health standard. All of the ore zone wells exceed the secondary drinking water standard for iron, and MW-1B and PW-4 also exceed the secondary drinking water standard for manganese (neither of these secondary standards are currently listed numeric water quality standards in Montana's October 2012 Circular DEQ-7).

Wells completed in the sulfide ore zone (MW-3, PW-4, PW-9) have the highest concentrations of dissolved solids and sulfate compared to the other wells. As previously discussed, MW-1B has similar water quality to these ore zone wells. The pH of water at these ore zone wells ranges from 6.04 to 7.31, which is slightly lower than other wells. Dissolved trace constituents that are present at detectable concentrations in the ore zone wells include antimony, arsenic, barium, cobalt (MW-1B only), iron, lead, manganese, mercury, molybdenum, nickel, strontium, thallium, uranium, and zinc. Strontium concentrations are elevated (8.08 to 16.2 mg/L) at MW-3 and PW-4 and exceed the human health standard of 4 mg/L. Arsenic concentrations at MW-1B, MW-3, and PW-4 range from 0.054 mg/L to 0.09 mg/L and exceed the human health standard of 0.010 mg/L. Arsenic speciation of samples from MW-1B and MW-3 indicate that the majority of the arsenic is present in reduced form as As (III). Concentrations of thallium at MW-1B (0.013 mg/L) also exceed the human health groundwater standard of 0.002 mg/L.

The analytical results from PW-7 (completed in the LCZ) indicate a sodium/potassium bicarbonate type water with highly basic pH (10.77 to 11.58 s.u.), higher concentrations of chloride and lower concentrations of sulfate than other wells on site. Trace constituents detected above the reporting limit include aluminum, antimony, arsenic barium, molybdenum, selenium, strontium, and zinc. Dissolved aluminum concentrations (0.187 to 1.03 mg/L) were much higher than observed at other wells on the site. Antimony was the only trace constituent that exceeded the groundwater human health standard. This sample

provides an initial assessment of the water quality in PW-7. However, the well did not produce sufficient water to allow for field parameter stabilization and drill mud was found in the well during the initial water level measurements and in subsequent monitoring events. These factors along with the atypical water quality including elevated aluminum, chloride, and sodium suggest the water quality from PW-7 may be impacted from drilling muds and fluids.

2.3 SEEPS AND SPRINGS DELINEATION

As a part of the initial water resource evaluation, nine seeps and 13 springs in the Project area have been identified, mapped, and some sampled for water quality and flow as a part of an inventory completed in 2011 (Hydrometrics, 2012b). A second series of flow measurements and water quality samples of seeps and springs was collected during July 2012. A number of springs discharge along the Volcano Valley Fault where the Flathead Quartzite is in contact with the Newland formation (Chen-Northern, 1989). Seeps and springs are identified on Figure 4.

The majority of the identified sites consist of small springs or seeps located in ephemeral channels in the headwaters of small unnamed tributaries. These springs form small boggy areas with limited flow and generally re-infiltrate within a few hundred feet downstream. A number of these springs have been developed for stock watering (indicated by a DS designator in Figure 4 and Table 6) and feed small livestock watering tanks. Slightly larger spring and seep areas were identified along the lower reaches of Coon Creek and on Little Sheep Creek and support perennial flow on these lower stream reaches.

2.3.1 Spring Flow Rates and Water Quality

Observed flow rates at the springs ranged from less than 1 gallon per minute (gpm) to over 100 gpm. Flow rates measured at baseline spring monitoring sites are summarized in Table 6.

TABLE 6. SUMMARY OF BASELINE SPRING FLOW DATA

Sta. Name	Flow Rate (gpm)			Sta. Name	Flow Rate (gpm)		
	min	max	avg		min	max	avg
SP-1	1.4	65	22	DS-1	<0.5	35	12
SP-2	2.2	9.4	6.9	DS-2	<0.5	12	4.7
SP-3	0.6	5.4	2.8	DS-3	4.9	117	38
SP-4	5.4	27	13	DS-4	2.2	20	8.7
SP-6	0.9	3.0	1.8	DS-5	<1	18	6.7
SP-7	9.4	112	38	DS-6	<0.5	18	7.3
SP-8	8.1	8.1	8.1				
SP-9	5.4	15	9.4				
SP-10	3.6	8.1	5.8				

Water samples have been collected at five of the primary spring sites (SP-1, SP-2, SP-3, SP-4, and SP-6) that surround the proposed exploration decline area. These springs generally exhibit neutral to slightly alkaline pHs (6.20-8.21) with moderate to high alkalinities (50-240 mg/L). Background nitrate concentrations are low (<0.1 - 0.68 mg/L) at all of the spring sites. Metals concentrations are within regulatory limits; however, manganese at springs SP-1 and SP-2 slightly exceeds the recommended secondary standard for drinking water of 0.05 mg/L, and iron at SP-3 exceeds the recommended secondary drinking water standard of 0.3 mg/L. SP-3 also exhibits slightly higher concentrations of some dissolved metals (Al, Cu, and Cr), but all are well below regulatory standards. Other samples from springs originating from gossan sites show similar water quality to the spring samples with no major differences in dissolved metals concentrations.

3.0 AQUIFER CHARACTERIZATION INVESTIGATIONS

A series of aquifer tests were conducted at the site that include both slug tests and short-term and long-term pumping tests to characterize the hydrogeologic characteristics of the principal stratigraphic units and the fault systems that bound the ore bodies. Each of the tests are described briefly below and references are provided for previous reports containing more detailed information on the individual tests. Table 7 summarizes salient information for each test and the estimated aquifer characteristics derived from test results. Aquifer test analyses are included in Appendix D.

Preliminary Testing

An initial aquifer test was completed for the project that used open PQ and HQ core holes (core diameters of 85 and 63.5 millimeters, respectively) to conduct preliminary tests (Tetra Tech, 2011). The test was designed to provide, for planning purposes, a very rough estimate of water volumes that might be expected during development of the ore deposit. The values obtained from this suggest, as a preliminary estimate, that water volumes as large as 400 to 600 (gpm) might be expected to be produced from the mined deposit zone during production, but are inconclusive due to the limited quality of the holes for this testing purpose.

PW-1 and PW-2 Aquifer Test

A more rigorous aquifer testing program was conducted in November 2011 to refine the earlier estimate of potential flow rates that could be encountered during mining based on the initial exploration/exploration decline (2011 decline) location which was to the north of the current proposed decline site (Hydrometrics, 2012a). Wells PW-1 and PW-2 were installed as pumping wells for the aquifer test. PW-1 was completed in shallow (YNL-0) dolomitic shale bedrock and PW-2 in the upper sulfide zone.

TABLE 7. SUMMARY OF AQUIFER TEST RESULTS

Observation Well	Analysis Method	Pumping Test	Hydraulic Conductivity (ft/day)	Hydraulic Conductivity (cm/sec)	Storativity
Alluvium					
MW-4A	Springer-Gelhar	MW-4A (slug)	216	7.6E-02	NA
	Springer-Gelhar		210	7.4E-02	NA
	Springer-Gelhar		208	7.3E-02	NA
Perched Aquifer					
PW-1	Theis	PW-1	0.07	2.5E-05	NA
	Moench		0.03	1.1E-05	NA
	Theis-Rec.		0.07	2.5E-05	NA
YNL-A					
MW-4B	Hvorslev	MW-4B (slug)	7.4	2.6E-03	NA
	Hvorslev		7.0	2.5E-03	NA
	Hvorslev		7.3	2.6E-03	NA
PW-3	Theis	PW-3	2.1	7.4E-04	NA
	Moench		1.6	5.6E-04	NA
	Theis-Rec.		1.1	3.9E-04	NA
	Theis	PW-8	5.8	2.0E-03	1.00E-04
	Moench		5.5	1.9E-03	8.00E-06
	Theis-Rec.		4.6	1.6E-03	NA
PW-8	Theis	PW-8	2.3	8.1E-04	NA
	Moench		1.0	3.5E-04	NA
	Theis-Rec.		1.3	4.6E-04	NA
USZ/UCZ					
PW-2	Theis	PW-2	0.06	2.1E-05	NA
	Moench		0.3	8.8E-05	NA
	Theis-Rec.		0.1	3.9E-05	NA
PW-4	Theis	PW-4	0.02	7.1E-06	NA
	Moench		0.01	3.5E-06	NA
	Theis-Rec.		0.02	7.1E-06	NA
PW-9	Theis	PW-9	0.2	8.5E-05	NA
	Moench		0.2	7.1E-05	NA
	Theis-Rec.		0.7	2.5E-04	NA
MW-3	Theis	PW-2	0.3	1.0E-04	2.70E-06
	Moench		0.3	8.8E-05	1.20E-04
	Theis-Rec.		0.2	7.1E-05	NA
	Theis	PW-9	0.7	2.5E-04	9.00E-05
	Moench		1.0	3.4E-04	6.00E-05
	Theis-Rec.		0.4	1.6E-04	NA
	Hvorslev		1.1	3.9E-04	NA
	Bouwer-Rice		1.1	3.9E-04	NA
YNL-B					
PW-10	Moench	PW-10	0.007	2.5E-06	NA
	Barker		0.006	2.1E-06	NA
	Theis-Rec.		0.001	3.5E-07	NA
LCZ					
PW-7	Bouwer	PW-7 (slug)	0.2	7.4E-05	NA
	Barker-Black		0.1	3.2E-05	NA
	Moench	PW-7	0.0003	1.1E-07	NA
	Barker		0.001	3.5E-07	NA
	Theis-Rec.		0.0003	9.9E-08	NA
Faults					
PW-5 (VVF)	Papadopolus	PW-5	0.09	3.2E-05	NA
	Barker		0.02	5.3E-06	NA
	Theis-Rec.		0.04	1.3E-05	NA
SC-11-008 (VVF)	Permeameter	NA	0.00003	1.00E-08	NA
SC-11-036 (VVF)	Permeameter	NA	0.00002	8.10E-09	NA
SC-12-129 (VVF)	Permeameter	NA	0.00002	5.40E-09	NA
SC-14-164 (VVF)	Permeameter	NA	0.00006	2.10E-08	NA
SC-14-170 (VVF)	Permeameter	NA	0.0007	2.50E-07	NA
PW-6 (Buttress Fault)	Papadopolus	PW-6	0.04	1.4E-05	NA
	Moench		0.01	3.5E-06	NA
	Theis-Rec.		0.004	1.3E-06	NA
	Barker		0.06	2.1E-05	NA
Coreholes					
AH-4	Theis	PW-1	0.6	2.1E-04	2.20E-05
	Moench		0.03	1.1E-05	8.00E-05
SC11-044	Theis	PW-2	0.3	1.1E-04	2.70E-06
	Moench		0.3	1.1E-04	1.20E-04
	Theis-Rec.		0.3	1.1E-04	NA
SC12-116	Theis	PW-3	1.2	4.2E-04	NA
	Moench		1.3	4.6E-04	NA
	Theis-Rec.		1.7	6.0E-04	NA

Datalogger/transducers were used to monitoring water levels in PW-1, PW-2, MW-3, and two exploration boreholes SC11-032 and SC11-044. Flow was also monitored near SP-6 in a small tributary drainage to Coon Creek, which is referred to informally by Tintina as Dry Creek. An 8-hour pumping test was conducted at PW-1 at a discharge rate of 1.5 gpm and a separate 5-day test was conducted at PW-2 at a discharge rate of approximately 5 gpm.

The analysis of drawdown data from the test yielded hydraulic conductivity estimates for the shallow (YNL-0) bedrock at PW-1 of approximately 0.03 to 0.6 ft/day (Appendix D). The fractured rock solutions produced the best fit to observed drawdown trends and yielded the lower range estimates. The PW-2 test yielded estimates of hydraulic conductivity for the upper sulfide zone of 0.06 to 0.3 ft/day. No change in surface flow was evident in Dry Creek during either test.

PW-3 and PW-4 Aquifer Tests

A more recent pumping test investigation was conducted in May 2012 to establish aquifer characteristics and revise estimates of potential inflow to the exploration decline based on a revised decline design (Hydrometrics, 2012c). Two new wells were installed as pumping wells for this investigation (PW-3 and PW-4). In addition, two existing exploration holes SC12-116 and SC12-117 were used as observation wells. Forty-eight hour pumping tests were conducted at test wells PW-3 and PW-4 to establish aquifer characteristics for the bedrock units that would be encountered along the path of the proposed exploration decline.

Aquifer test results were analyzed using AQTESOLV (v.4.01) to calculate aquifer transmissivities, hydraulic conductivities, and storage coefficients. Analyses were conducted using solutions for confined aquifers, leaky confined aquifers, and for fractured rock systems. Drawdown results from the PW-3 pumping test for both PW-3 and SC12-116 yielded similar hydraulic conductivity estimates with hydraulic conductivity values for the shallow bedrock unit (YNL-A) ranging from 1.1 to 2.2 feet/day. The analysis of PW-4 drawdown yielded hydraulic conductivity estimates for the USZ of approximately 0.01 to 0.02 ft/day (Appendix D).

PW-5 Aquifer Test

PW-5 was completed in the VVF near its intersection with the UCZ (Figure 3) to help define the hydrologic characteristics of the fault. The well was completed to a depth of 550 feet and penetrates approximately 50 feet into a zone of fault gouge and fractured rock. Exploration boreholes show similar fault gouge material in cores taken through the VVF.

The aquifer test at PW-5 was conducted in January 2015. It was scheduled to be conducted for 72 hours; however, water levels dropped to within a few feet of the pump intake during the step test at the initial flow rate of only 1 gpm. Conducting the aquifer test at a lower rate was not feasible as a lower pumping rate would not adequately cool the pump motor and risk damaging the pump. Therefore, the drawdown data from the 1 gpm initial test was used to evaluate aquifer characteristics.

The water level drew down from 503 feet at the start of the test to 530 feet (within 5 feet of pump intake) after pumping for approximately 20 minutes. Water level recovery was recorded for approximately 17 minutes after the pump was shut off. There was an initial recovery response that was relatively rapid and then water levels essentially stabilized 8 feet lower than pre-test levels. Water quality samples were not collected from PW-5 as there was insufficient time to collect the sample due to the rapid decline in water levels.

The test results were not definitive as the quantity of water pumped during the test could be accounted for almost entirely by the change in well volume. After an initial recovery response, the calculated rate of inflow to the well was less than 0.01 gal/min. This is consistent with the slow recovery observed after drilling this well. Hydraulic conductivity estimates from the PW-5 aquifer test using solutions that account for well storage ranged from 0.02 to 0.09 ft/day (Hydrometrics, 2015). Although these estimates are one to two orders of magnitude lower than the higher estimated permeability of the USZ and two to three orders of magnitude lower than the YNL-A permeability estimates, they may not accurately characterize the permeability of the VVF since the aquifer response was effectively overshadowed by the well storage effects.

VVF Permeameter Testing

To further assess the permeability of the volcano valley fault, five soil samples of the gouge material within the fault zone were taken from three separate exploration cores and submitted to Pioneer Technical Service's for hydraulic conductivity analysis using a Flexible Wall Permeameter test (ASTM Method D5084). The results, shown in Table 8, indicate that the fault gouge present within the Volcano Valley Fault has a very low permeability with hydraulic conductivities ranging from 7.1×10^{-4} to 1.5×10^{-5} ft/day and an average of 2.8×10^{-5} ft/day.

TABLE 8. FLEX WALL PERMEABILITY TEST RESULTS FOR VOLCANO VALLEY FAULT SOIL SAMPLES

Lab No.	Sample No.	Confining Pressure (psi)	Hydraulic Conductivity (ft/day)	Hydraulic Conductivity (cm/sec)
G15247 SC11	SC-11-008	34.6	2.8×10^{-5}	1.0×10^{-8}
G15248 SC11	SC-11-036	37.2	2.3×10^{-5}	8.1×10^{-9}
G15249 SC12	SC-12-129	42.0	1.5×10^{-5}	5.4×10^{-9}
G15250 SC14	SC-14-164	50.0	6.0×10^{-5}	2.1×10^{-8}
G15251 SC14	SC-14-170	41.3	7.1×10^{-4}	2.5×10^{-7}

PW-6 Aquifer Test

The PW-6 borehole was drilled to a total depth of 1,234 feet bgs and completed within the Buttress Fault Zone. An aquifer test was conducted on PW-6 in October 2014 at a discharge rate of 6 gpm. The pumping phase of the test was shut down after approximately 100 minutes and produced a drawdown of approximately 275 feet. Water levels were recorded during the pumping and recovery phases of the aquifer test.

The drawdown curve for this test shows a linear drawdown trend typical of a low yield well where well bore storage is a high percentage of the water being discharged. Analyses were performed using several analytical solutions that correct for well bore storage effects including Papadopoulos-Cooper (1967) for confined aquifers, and two dual porosity solution for fractured rock systems (Moench, 1984 and Barker, 1988). This recovery solution was

also used to estimate transmissivities as the recovery data for single well tests is typically more reliable. Estimates of hydraulic conductivity at well PW-6 (completed in the Buttress Fault) ranged between 0.004 ft/day and 0.06 ft/day (Appendix D).

PW-6N Air Test

Well PW-6 was modified/deepened in the spring of 2015 to evaluate the hydrologic characteristics of the underlying Neihart quartzite; the new well is called PW-6N. Well PW-6N was completed with an open borehole below the cemented screen of PW-6, and extends into supplemental fractures in the Neihart Formation associated with the Buttress fault. Air lift testing after taking the borehole to depth produced very high flows; estimated at 500 plus gallons per minute. No additional testing was conducted on PW-6N; however, the data indicate there are high permeability fractures within the Neihart quartzite adjacent to the Buttress Fault.

PW-7 Slug Test/Short-Term Aquifer Test

Well PW-7 is located within the Sheep Creek drainage; the borehole was drilled to a depth of 1,350 feet bgs and completed in the lower ore zone. A slug test rather than a pumping test was conducted on PW-7 due to the low yield of the well, and the fact that the well is closed off at the surface due to artesian conditions (static water level was approximately 12 feet above the ground surface). A rising head slug test was conducted on October 2014. The well was instrumented with a pressure gauge and a pressure transducer. Water was released to reduce pressure at the wellhead to zero and then the well was shut in and allowed to recover. Two separate tests were conducted.

The water level was displaced approximately 8 feet during the PW-7 slug tests. Water levels recovered slowly after closing the spigot, taking approximately 135 minutes to stabilize to within 0.5 inches of the pre-test water level. The PW-7 slug tests were analyzed using analytical solutions for confined and unconfined porous media aquifers and for a dual porosity fractured aquifer. The analyses produced hydraulic conductivities ranging from 0.2 ft/day to 0.1 ft/day (Appendix D). These estimated hydraulic conductivities are similar to results from the other Newland Formation wells. However, they are not consistent with the

recovery of the well after well completion; which took more than 30 days to recover to the static condition.

In addition to the slug test, drawdown was measured during water quality monitoring at PW-7 during the March 2015 monitoring event to provide additional data on the aquifer characteristics of the LCZ. The well was purged for approximately 39 minutes at 1-1.5 gpm prior to shutting down the pump; the drawdown in the well was measured at approximately 36 feet. The drawdown curve did not stabilize during well purging. Water levels did not recover to pre-pumping conditions 14 days after the well was sampled. The PW-7 short-term aquifer tests were analyzed using analytical solutions for fracture bedrock and recovery/residual drawdown analyses. Hydraulic conductivity estimates from the PW-7 aquifer tests ranged from 0.001 ft/day to 0.0003 ft/day. Although the drawdown data from the well sampling is limited in duration, the lower hydraulic conductivity estimates from this test appear to be more representative of the slow water level recovery that was observed after well completion and during well sampling.

PW-8 Aquifer Test

A long-term (31-day) aquifer test was conducted on PW-8 in July and August 2014. Well PW-8 is completed in YNL-A shale just above the contact with the Upper Sulfide Zone (USZ). In addition to characterizing the permeability of the USZ unit, the purpose of the extended test was to assess the extent to which extended pumping would affect water levels in overlying units and at nearby surface water sites. Additional monitoring sites were setup prior to conducting the aquifer test. Three temporary piezometers were installed in the Coon Creek (PZ-12), Sheep Creek (PZ-11), and Dry Creek (PZ-10) alluvial systems (Figure 3). Three surface water sites were also monitored during the PW-8 aquifer test: SW-3 on Coon Creek upgradient of the hay meadow, SW-14-1 on Coon Creek in the hay meadow, and SW-14-2 on Dry Creek directly south of PW-8 (Figure 2). Sites SW-14-1 and SW-14-2 are temporary sites that were established for the aquifer test monitoring program.

Datalogger transducers were installed at 11 observation sites to collect background water levels for 28 days prior to the start of the PW-8 aquifer test. A step test was conducted on

PW-8 on August 7, 2014. The flow rates for the step test were approximately 2.2 gpm, 5.0 gpm, and 10 gpm. The well showed a steep decline in water levels during the final step, indicating the well might not be capable of sustaining flow at 10 gpm.

A 31-day pumping test was conducted at PW-8 from August 8 to September 8, 2014. Water levels were monitored using datalogger transducers at 11 observation sites. Manual water levels were collected at more distant observation sites. The PW-8 aquifer test was started on August 8 at a discharge rate of 5.5 gpm. The discharge rate was increased to approximately 8 gpm on August 11, 2014 as water levels had stabilized at the lower discharge rates. The discharge rate was increased again on August 14, 2014 to 10 gpm to maximize the drawdown within the pumping well and observation wells. The discharge remained at this rate for the remaining 24 days of the test with the exception of a short-term shut down of the well due to a power outage. A power outage occurred at approximately 1:15 on the morning of August 23, 2014, which resulted in the pump being shut down for approximately seven hours before power and pumping could be reestablished. The PW-8 aquifer test was shut down on September 8, after 31 days of pumping.

Wells that exhibited measureable drawdown during the PW-8 aquifer test include pumping well PW-8 and observation wells PW-4, PW-3, and MW-1B (Figure 3). The maximum drawdown at PW-8 was approximately 44 feet. Well PW-4, located 23 feet to the northeast, had a maximum drawdown of 6.5 feet. A maximum drawdown of approximately 2.4 feet was observed at PW-3, which is located 709 feet south of PW-8. Piezometer PZ-10, which is completed in the shallow groundwater system associated with Coon Creek, did not have any measureable drawdown from the PW-8 aquifer test. This suggests that Coon Creek and the shallow groundwater associated with Coon Creek are not directly connected to the deeper groundwater system in the vicinity of the USZ. The remaining observation sites including all piezometers in the shallow aquifer systems associated with Sheep Creek, Coon Creek, and Dry Creek did not show any measureable drawdown from the PW-8 aquifer test. Water levels in all of the wells that exhibited drawdown recovered slightly during the power outage on August 23. With the exception of Well MW-1B, drawdown returned to the same level shortly after the pump was restarted.

Pumping well PW-8 recovered to pre-test levels within two days of shutting down the pump. Water levels recovered 1.4 feet above pretest levels in PW-8. Observation wells PW-4 and PW-3 recovered to within pretest levels in 2.5 days and 3 days, respectively; with water levels in both wells recovering above (1.0 and 0.7 feet, respectively) the pretest levels.

Curve-matching graphs for the wells that had measureable drawdown during the PW-8 and PW-9 aquifer tests are included in Appendix D. The drawdown curves from the PW-8 pumping test indicate that wells PW-8 and PW-3 (both of which are completed in YNL-A) yielded similar permeabilities. Estimated hydraulic conductivity values range from 4.6 to 5.8 ft/day based on the observed drawdown trend at PW-3 during the PW-8 pumping test, and from 1.0 to 2.3 ft/day at the PW-8 pumping well. The PW-3 hydraulic conductivity estimate from the PW-8 test is slightly higher than estimates from the two previous tests conducted on PW-3 in 2011 and 2012, which yielded hydraulic conductivity values of 1.1 to 2.1 ft/day (Table 8). The calculated hydraulic conductivities assume a 50-foot aquifer thickness, which is equal to the thickness of the gravel pack in PW-8. A wide range of storativity estimates (1×10^{-4} to 8×10^{-6}) were derived from the PW-3 drawdown curve. The storativity value from the Theis solution may be overestimated since the drawdown curve is not similar to a typical Theis curve.

PW-9 Aquifer Test

A step test was conducted at PW-9 on September 17, 2014 with discharge rates of approximately 3, 6, and 9 gpm. The discharge rates for each step were sustained for 80 minutes. A long-term aquifer test at PW-9 was conducted for 19 days from September 25 to October 14. The discharge rate for the PW-9 aquifer test was maintained at 5 gpm from September 25, 2014 to October 8, 2014 at which point the discharge rate was increased to 6 gpm in an attempt to maximize the drawdown in the pumping well and observations sites without dewatering the well. The 6 gpm discharge rate was maintained for six days until the pumping test was shut down on October 14, 2014 as drawdown had stabilized in the pumping well and observation wells.

Water levels were monitored during drawdown and recovery phases of the test using datalogger transducers at 11 observation sites. In addition, manual water levels were collected at more distant observation sites. Flow and stage measurements were collected at three surface water sites (SW-14-1, SW-14-2, and SW-3) and one spring (SP-06).

Only four wells exhibited drawdown during the PW-9 pumping test: PW-9, PW-10, MW-3, and MW-9 (Figure 3). Wells PW-9 and MW-3 are completed in the USZ, whereas wells MW-9 and PW-10 are completed above and below the USZ, respectively. The maximum drawdown at well PW-9 was 62.7 feet at the end of the pumping test. Well MW-3, located approximately 380 feet to the west of PW-9, had the largest drawdown (12.4 feet) of the observation wells. Although well PW-10 and MW-9 are located within 16 to 21 feet of PW-9 laterally, the maximum drawdown was much less (7.6 feet and 8.7 feet, respectively) than at MW-3. Well MW-3 is completed in the same hydrostratigraphic unit as PW-9 and could be considered to be fairly well connected to PW-9. The subdued drawdown in nearby well PW-10, completed below the USZ, and MW-9, completed above the USZ, suggests the hydrostratigraphic units above and below the USZ are only partially or poorly connected to the USZ and UCZ subunit. Drawdown was not observed in the more distal observation wells monitored during the PW-9 aquifer test. The analysis of the drawdown curves for PW-9 and MW-3 yielded hydraulic conductivity estimates of 0.2 to 0.7 ft/day and 0.4 to 1.0 ft/day, respectively (Appendix D). Storativity estimates from well MW-3 ranged from 6.0×10^{-5} to 9.0×10^{-5} .

Weekly surface water flow and/or stage monitoring was conducted at three surface water sites (SW-3, SW-14-1, and SW-14-2) and in piezometers completed in the shallow alluvial systems during both the PW-8 and PW-9 aquifer tests. The surface water sites and piezometers showed no influence from extended pumping of the bedrock aquifer at the proposed development depths.

PW-10 Aquifer Test

Aquifer characteristics were evaluated at PW-10 by monitoring water level drawdown during well purging for water quality sampling. The water level in PW-10 drew down

approximately 34 feet after pumping for 26 minutes. Water levels recovered within 0.01 feet approximately 20 minutes after cessation of well purging. Analytical methods were used to estimate hydraulic conductivity of the YNL-B below the UCZ/USZ; these ranged between 0.001 ft/day and 0.007 ft/day, which is in the lower range of results from well completed in the Newland Shale above the Volcano Valley Fault.

In addition to the aquifer tests described above, slug tests were also performed on monitoring wells MW-4A and MW-4B following well completion and development. Slug tests at MW-4A, completed in the Sheep Creek alluvium, produced oscillatory fluctuations in water levels during testing due to the inertial effects from an extremely rapid recovery response. This type of response is common in high permeability aquifers and was analyzed using an analytical solution developed by Springer and Gelhar (1991) that extends the Bouwer-Rice (1976) solution for a slug test in a homogeneous, anisotropic unconfined aquifer to include inertial effects in the test well. The solution yielded an estimated hydraulic conductivity for the Sheep Creek alluvial aquifer on the order of 200 feet per day.

Slug testing at MW-4B, which is completed in the shallow YNL-A bedrock, produced a more conventional response that was analyzed using solutions developed by Bouwer and Rice (1976) and Hvorslev (1951) and yielded an estimated hydraulic conductivity of 7 feet per day for the shallow bedrock.

4.0 GROUNDWATER SURFACE WATER INTERACTIONS

4.1 SHEEP CREEK

Potentiometric data indicate that Sheep Creek is hydrologically connected with the alluvial aquifer in the Sheep Creek Valley. Surface water monitoring data show a general increase in flow from upstream monitoring sites (USGS-SC1 and SW-2) to downstream (SW-1); however, the majority of that increase appears to be attributable to tributary inflow. An initial synoptic survey was conducted in August 2012 to characterize inflows to Sheep Creek, in the project area. The location of the synoptic survey sites are shown in Figure 14. The large decreases and increases in flow are inconsistent with hydrologic conditions in this area. The synoptic results showed over 6 cfs of streamflow loss between SGSC-01 and SGSC-04 and approximately 2 cfs of increase through the canyon (Table 9). Flows would typically be expected to increase in surface systems as alluvial systems are pinched out where streams enters narrow canyons and potentiometric data in the Sheep Creek alluvial system appear to lend support to the concept that Sheep Creek is receiving groundwater recharge in this area. The atypical trends shown in the August synoptic survey may have been related to irrigation effects. The synoptic survey was conducted shortly after irrigation was discontinued in the hay meadow. The cessation of flood irrigation in the hay meadow represents a large stress to the hydrologic system and there may not have been sufficient time for the systems to re-equilibrate.

A second survey was conducted in October 2012 to further evaluate the groundwater/surface water interaction on Sheep Creek and two small drainages (Coon Creek and Brush Creek) adjacent to the project area. The results of the October 2012 survey are tabulated in Table 10. The October 2012 synoptic survey on Sheep Creek included additional monitoring sites on Sheep Creek to provide supplemental data to evaluate the changes seen in the August 2012 survey. During this second synoptic survey changes in discharge on Sheep Creek were generally within the measurement error (10-15%) throughout the survey area. The only exception was at SGSC-03 below little Sheep Creek, where the measured flow was almost 4 cfs lower than would be expected based on the flow in Sheep Creek combined with the

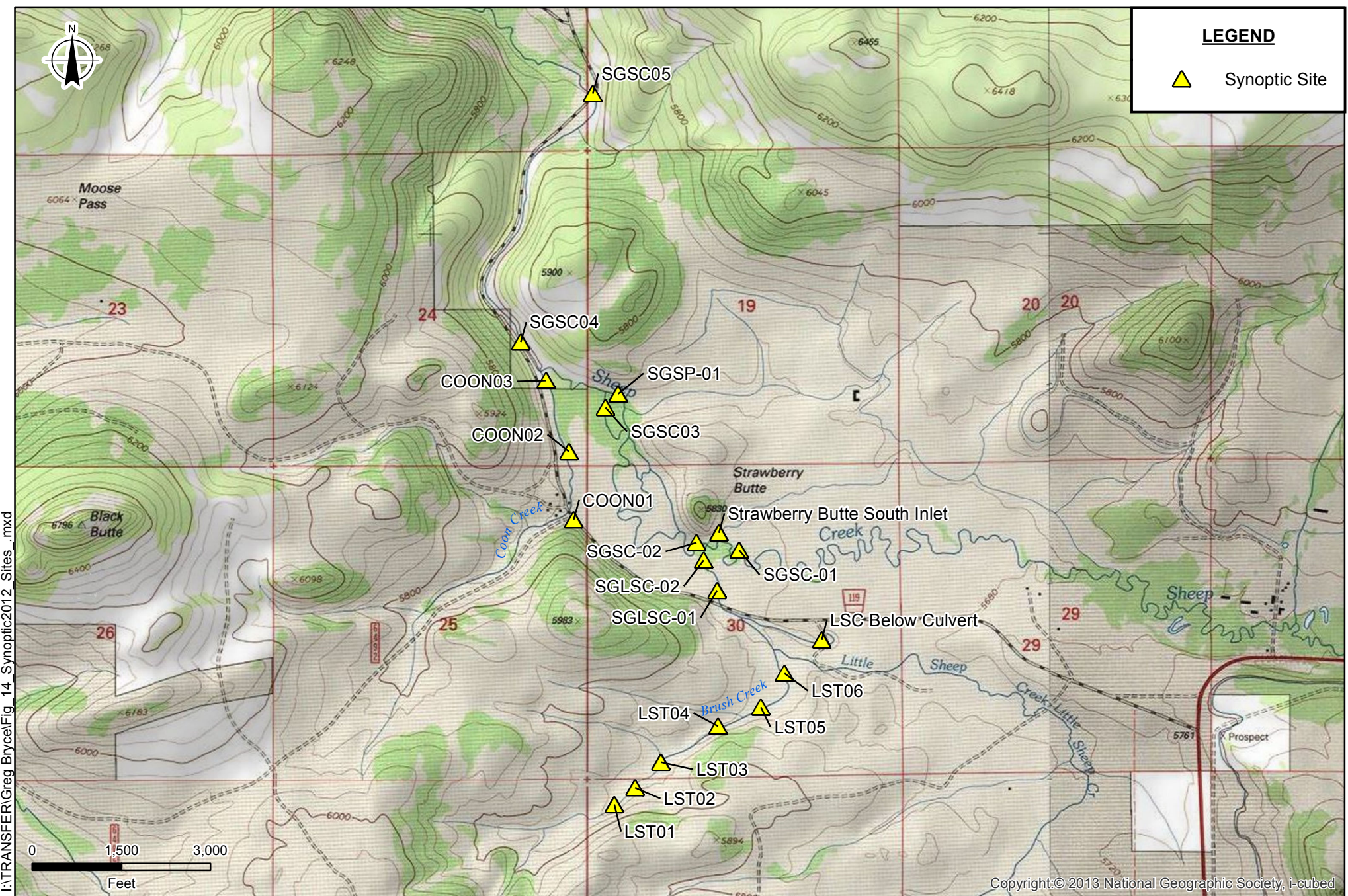

I:\TRANSFER\Greg Bryce\Fig_14_Synoptic2012_Sites_.mxd

Figure 14
2012 Synoptic Survey Sites
Black Butte Copper Project
Meagher County, Montana

TABLE 9. AUGUST 2012 SYNOPTIC SURVEY RESULTS

Site	Sheep Creek Discharge (cfs)	Tributary Discharge (cfs)	Sum of Sheep Creek and Tributary Flow (cfs)	Notes
SGSC-01	14.03	--	--	Sheep Creek above Strawberry Butte South Inlet, most upstream Sheep Creek Site
Strawberry Butte South	--	1.3	15.33	Mouth of Strawberry Butte South Inlet upstream of Sheep Creek Confluence
SGLSC-01	--	2.2	17.53	Little Sheep Creek downstream of the Sheep Creek Rd culvert
SGSP-01	--	1.33	--	Mouth of Spring Creek before Sheep Creek confluence
Coon-03	--	0.52	--	Mouth of Coon Creek upstream of Sheep Creek confluence
SGSC-04	13.02	--	--	Sheep Creek downstream of Coon Creek confluence in canyon north of hay meadow
SGSC-05	15.24	--	--	Sheep Creek at quarterly monitoring site SW-1

TABLE 10. OCTOBER 2012 SYNOPTIC FLOW RESULTS

Site	Sheep Creek Discharge (cfs)	Tributary Discharge (cfs)	Sum of Sheep Creek and Tributary Discharge (cfs)	Notes
Brush Creek Survey				
LST-01	--	Dry	--	Most upstream site on Brush Creek
LST-02	--	0.07	--	Moving downstream ↓
LST-03	--	0.09	--	
LST-04	--	0.1	--	
LST-05	--	0.1	--	
LST-06	--	0.16	--	Most downstream site on Brush Creek
Coon Creek Survey				
Coon-01	--	0.1	--	Coon Creek just as it enters the hay meadow, SW-3
Coon-02	--	0.22	--	Coon Creek mid-point in the hay meadow
Coon-03	--	0.19	--	Coon Creek immediately upstream of Sheep Creek confluence
Sheep Creek Survey				
2SGSC-01	21.5	--	--	Most upstream site in hay meadow
SGSC-02	22.2	--	--	Sheep Creek upstream of Little Sheep Creek confluence (includes discharge from un-named tributary south of Strawberry Butte)
SGLSC-02	--	1.12	23.32	Little Sheep Creek before Sheep Creek confluence
SGSC-03	19.51	--	--	Sheep Creek upstream of Spring Creek confluence
SGSP-01	--	0.44	--	Spring Creek before Sheep Creek confluence
Coon-03	--	0.19	20.14	Coon Creek upstream of Sheep Creek confluence
SGSC-04	20.57	--	--	Sheep Creek downstream of Coon Creek confluence in canyon north of hay meadow
SGSC-05	19.05	--	--	Sheep Creek at quarterly monitoring site SW-1

measured inflow from Little Sheep Creek. This magnitude of change cannot easily be accounted for by stream flow loss near the SGSC-03 measurement site, however, this gaging site is in a location where Sheep Creek is highly braided and the channel is not ideal for obtaining an accurate discharge measurement. The confidence level of the data from this station is therefore low. With this exception, changes in stream flow in Sheep Creek during the October 2012 synoptic survey appear to be largely accounted for by tributary inflows. Groundwater inflow to Sheep Creek within the Project area was not measurable in the 2012 synoptic survey and indicates that groundwater contributions to the stream account for less than 10 to 15% of the total flow rate on this stream reach.

A simple Darcy's flux calculation was used to confirm that the estimated flux from the Sheep Creek alluvial groundwater system to Sheep Creek in this lower reach is consistent with the small fluctuations shown in the synoptic results. Darcy's Law can be used to estimate flow rate given a hydraulic conductivity (K), hydraulic gradient (I) and flow cross sectional area (A) where:

$$\text{Discharge (Q)} = K \times I \times A$$

Given an assumed thickness of the Sheep Creek alluvium of 16 feet as observed at MW-4A, and an assumed maximum width of 1,500 feet, an average hydraulic gradient (I) of groundwater of 0.008 and an average hydraulic conductivity (K) of 200 feet/day, Darcy's Law yields a groundwater flux estimate of 200 gpm (0.44 cfs) flowing through the alluvium towards Sheep Creek within the immediate project area. If all of this discharged to Sheep Creek, it would be equivalent to just over 2% of the baseflow observed in Sheep Creek during the synoptic survey. This confirms that groundwater inputs to Sheep Creek within this reach are too small to physically quantify using open channel flow measurement techniques.

4.2 BRUSH CREEK AND COON CREEK

The synoptic survey on Brush Creek indicates discharge of shallow groundwater at the head of this draw and then no measureable change in flow between sites LST-02 and LST-05

(Figure 14). There was a small increase (0.06 cfs) between LST-05 and LST-06 as Brush Creek approaches the Little Sheep Creek alluvial system. Water quality data were used to further assess groundwater and surface water interactions on Brush Creek in the 2013 investigation, and that evaluation found that the water quality in Brush Creek was not indicative of groundwater from the shallow bedrock groundwater system in the vicinity of the proposed underground LAD area (Hydrometrics, 2013a). The source of the small increase in flow below LST-05 is unknown but may be associated with the Little Sheep Creek alluvial system.

A synoptic survey was conducted on the lower reach of Coon Creek where it enters the Sheep Creek alluvial system to its confluence with Sheep Creek. The discharge in Coon Creek at the most upstream site (COON-01) was approximately 0.1 cfs. Coon Creek discharge approximately doubled between sites COON-01 and COON-02; the discharge remained near 0.2 cfs until its confluence with Sheep Creek (Table 10). Data from the drilling at PW-3 and the PW-8 pumping test and water level elevation data provide evidence that Coon Creek above SW-3 is not in direct connection with the deeper bedrock groundwater system.

5.0 REFERENCES

- ASTM D5084-10, Standard Test Methods for Measurement of Hydraulic Conductivity of Saturated Porous Materials Using a Flexible Wall Permeameter, ASTM International, West Conshohocken, PA, 2010.
- Barker, J.A., 1988. A generalized radial flow model for hydraulic tests in fractured rock, *Water Resources Research*, vol. 24, no. 10, pp. 1796-1804.
- Bouwer, H. and R.C. Rice, 1976. A slug test method for determining hydraulic conductivity of unconfined aquifers with completely or partially penetrating wells, *Water Resources Research*, vol. 12, no. 3, pp. 423-428.
- Chen-Northern, Inc., 1989. Sheep Creek Project – Hydrology Screening Study. Prepared for Cominco American Resources Inc. Report dated June 1989. 13 p. cover letter, appendices of data, and a fold out plate.
- Hvorslev, M.J., 1951. Time Lag and Soil Permeability in Ground-Water Observations, *Bull. No. 36, Waterways Exper. Sta. Corps of Engrs, U.S. Army, Vicksburg, Mississippi*, pp. 1-50.
- Hydrometrics, Inc., 2012a. Proposed Decline Hydrological Assessment, Black Butte Copper Project. January 2012.
- Hydrometrics, Inc., 2012b. 2011 Spring and Seep Inventory, Black Butte Copper Project. January 2012.
- Hydrometrics, Inc., 2012c. Hydrological Assessment of Proposed Exploration Decline, Black Butte Copper Project. August 2012.
- Hydrometrics, Inc., 2013a. Hydrological and Geochemical Assessment of Proposed Underground LAD Area, Black Butte Copper Project. November 2013.
- Hydrometrics, Inc., 2013b. Water Resources Monitoring Field Sampling and Analysis Plan, Black Butte Copper Project. Revised March 2013.
- Hydrometrics, Inc., 2015. 2013 and 2014 Hydrologic Assessment Report, Black Butte Copper Project. April 2015.
- Moench, A.F., 1984. Double-porosity models for a fissured groundwater reservoir with fracture skin, *Water Resources Research*, vol. 20, no. 7, pp. 831-846.
- Montana Bureau of Mines and Geology (MBMG), 2011 <http://mbmggwic.mtech.edu/> Data Website. Viewed August 2011.

- Papadopoulos, I.S. and H.H. Cooper, 1967. Drawdown in a well of large diameter, *Water Resources Research*, vol. 3, no. 1, pp. 241-244.
- Resource Modeling, Inc. (RMI), 2010. Sheep Creek Project – Upper Copper Zone Inferred Resource. Prepared for Tintina Alaska Exploration Inc. December 20, 2010.
- Springer, R.K. and L.W. Gelhar, 1991. Characterization of large-scale aquifer heterogeneity in glacial outwash by analysis of slug tests with oscillatory response, Cape Cod, Massachusetts, U.S. Geol. Surv. Water Res. Invest. Rep. 91-4034, pp. 36-40.
- Tetra Tech, Inc., 2011. Technical Memorandum: DRAFT – Initial Hydraulic Characterization – Sheep Creek Project, Montana. Submitted to Tintina. August 10, 2011.
- Theis, C.V., 1935. The relation between the lowering of the piezometric surface and the rate and duration of discharge of a well using groundwater storage, *Am. Geophys. Union Trans.*, 16, pp. 519-524
- Zieg, J. 2016. Personal communications with Vice President of Exploration for Tintina Montana.

APPENDIX A

**WATER QUALITY MONITORING DATABASE
(LOCATED ON CD)**

APPENDIX B

WATER QUALITY STATISTICS

SW-1 - Statistical Analysis
Reporting Period - 5/2011 - 12/2016

Parameter	Units	No. Samples	No. Detects	Min.	Max.	Mean	25% PCTL	75% PCTL	95% PCTL	SD.
Flow	Cubic Ft Sec	--	--	8.8	613	78	21	104	193	99
pH - Field	s.u.	--	--	5.3	8.71	7.90	7.72	8.30	8.52	0.68
Specific Conductance	umhos/cm	--	--	176	363	284	239	321	349	55
Water Temperature	Deg C	--	--	-0.92	15.5	5.1	0.1	9.0	12.8	4.7
Dissolved Oxygen	mg/l	--	--	3.91	15	10.9	10.0	12.2	13.5	1.9
Total Dissolved Solids	mg/l	48	48	104	227	168	151	186	202	29
Total Suspended Solids	mg/l	42	16	4	43	14	5	18	32	10
Alkalinity as CaCO3	mg/l	48	48	87	200	153	130	180	187	32
Bicarbonate as HCO3	mg/l	7	7	110	220	167	125	200	214	46
Carbonate as CO3	mg/l	7	5	<1	11	8	8	10	11	3
Chloride	mg/l	48	47	1	5	1	1	2	3	1
Fluoride	mg/l	48	13	0.1	0.2	0.1	0.1	0.1	0.1	--
Sulfate	mg/l	48	48	2	18	5	4	6	8	3
Total Hardness	mg/l	48	47	<7	199	149	119	176	191	34
Calcium (DIS)	mg/l	47	47	22	55	42	34	49	54	9
Magnesium (DIS)	mg/l	47	47	6	15	11	9	13	14	3
Sodium (DIS)	mg/l	47	47	1	3	1	2	2	3	0
Potassium (DIS)	mg/l	47	44	1	3	2	1	1	3	1
Nitrate + Nitrite as n	mg/l	48	21	0.01	0.15	0.06	0.02	0.07	0.14	0.04
Nitrogen, Total (Calc)	mg/l	9	4	<0.5	4.5	3.0	2.5	3.2	4.2	1.0
Total Kjeldahl Nitrogen as n	mg/l	10	4	<0.5	4.5	3.0	2.4	3.2	4.2	1.0
Total Persulfate Nitrogen	mg/l	23	21	<0.04	0.23	0.13	0.08	0.18	0.20	0.06
Phosphorus (TOT)	mg/l	32	30	0.005	0.09	0.02	0.01	0.02	0.03	0.02
Aluminum (DIS)	mg/l	47	19	<0.009	0.333	0.100	0.023	0.145	0.321	0.112
Aluminum (TRC)	mg/l	8	8	<0.009	2.11	0.64	0.10	0.87	2.09	0.90
Antimony (DIS)	mg/l	3	0	<0.0005	--	--	--	--	--	--
Antimony (TRC)	mg/l	47	0	<0.0005	--	--	--	--	--	--
Arsenic (DIS)	mg/l	3	0	<0.001	--	--	--	--	--	--
Arsenic (TRC)	mg/l	47	10	<0.001	0.001	0.001	0.001	0.001	0.001	0.000
Barium (DIS)	mg/l	3	3	0.082	0.095	0.090	0.088	0.094	0.095	0.007
Barium (TRC)	mg/l	47	47	0.083	0.127	0.104	0.099	0.110	0.123	0.011
Beryllium (DIS)	mg/l	3	0	<0.0008	--	--	--	--	--	--
Beryllium (TRC)	mg/l	47	0	<0.0008	--	--	--	--	--	--
Cadmium (DIS)	mg/l	3	0	<0.00003	--	--	--	--	--	--
Cadmium (TRC)	mg/l	47	4	<0.00003	0.0002	0.0001	0.0000	0.0001	0.0002	0.0001
Chromium (DIS)	mg/l	3	0	<0.001	--	--	--	--	--	--
Chromium (TRC)	mg/l	47	3	<0.001	0.004	0.003	0.003	0.004	0.004	0.002
Cobalt (DIS)	mg/l	3	0	<0.005	--	--	--	--	--	--
Cobalt (TRC)	mg/l	47	0	<0.005	--	--	--	--	--	--
Copper (DIS)	mg/l	3	0	<0.001	--	--	--	--	--	--
Copper (TRC)	mg/l	47	7	<0.001	0.003	0.002	0.002	0.003	0.003	0.001
Iron (DIS)	mg/l	3	1	<0.03	--	--	--	--	--	--
Iron (TRC)	mg/l	47	47	<0.03	1.86	0.37	0.16	0.41	1.11	0.40
Lead (DIS)	mg/l	3	0	<0.0003	--	--	--	--	--	--
Lead (TRC)	mg/l	47	12	<0.0003	0.0017	0.0007	0.0004	0.0008	0.0016	0.0005
Manganese (DIS)	mg/l	3	3	0.006	0.009	0.007	0.006	0.008	0.009	0.002
Manganese (TRC)	mg/l	47	47	0.009	0.08	0.02	0.01	0.02	0.04	0.01
Mercury (DIS)	mg/l	4	0	<0.00001	--	--	--	--	--	--
Mercury (TRC)	mg/l	47	11	<0.000005	0.00002	0.00001	0.00001	0.00002	0.00002	0.00001
Molybdenum (DIS)	mg/l	3	0	<0.005	--	--	--	--	--	--
Molybdenum (TRC)	mg/l	47	0	<0.001	--	--	--	--	--	--
Nickel (DIS)	mg/l	3	0	<0.01	--	--	--	--	--	--
Nickel (TRC)	mg/l	47	8	<0.001	0.002	0.001	0.001	0.002	0.002	0.001
Selenium (DIS)	mg/l	3	0	<0.001	--	--	--	--	--	--
Selenium (TRC)	mg/l	47	0	<0.001	--	--	--	--	--	--
Silver (DIS)	mg/l	3	0	<0.0005	--	--	--	--	--	--
Silver (TRC)	mg/l	47	0	<0.0002	--	--	--	--	--	--
Strontium (DIS)	mg/l	3	2	<0.1	0.1	0.1	0.1	0.1	0.1	0
Strontium (TRC)	mg/l	47	42	0.0779	0.147	0.116	0.105	0.127	0.131	0.016
Thallium (DIS)	mg/l	3	0	<0.0002	--	--	--	--	--	--
Thallium (TRC)	mg/l	47	0	<0.0002	--	--	--	--	--	--
Uranium (DIS)	mg/l	3	2	<0.0003	0.0004	0.0004	0.0003	0.0004	0.0004	0.0001
Uranium (TRC)	mg/l	47	9	<0.0003	0.0004	0.0004	0.0003	0.0004	0.0004	0.0001
Zinc (DIS)	mg/l	3	0	<0.01	--	--	--	--	--	--
Zinc (TRC)	mg/l	47	18	<0.002	0.006	0.004	0.002	0.005	0.006	0.001

SW-2 - Statistical Analysis
Reporting Period - 5/2011 - 12/2016

Parameter	Units	No. Samples	No. Detects	Min.	Max.	Mean	25% PCTL	75% PCTL	95% PCTL	SD.
Flow	Cubic Ft Sec	--	--	4.0	250	57	16	101	132	55
pH - Field	s.u.	--	--	6.45	8.73	7.96	7.76	8.24	8.53	0.50
Specific Conductance	umhos/cm	--	--	2.55	388	274	225	323	344	68
Water Temperature	Deg C	--	--	-0.9	15.8	5.1	0.0	9.8	13.2	4.9
Dissolved Oxygen	mg/l	--	--	6.35	16.18	11.0	9.9	11.7	13.9	1.7
Total Dissolved Solids	mg/l	50	50	112	223	166	149	186	194	28
Total Suspended Solids	mg/l	45	13	<4	105	23	7	24	70	27
Alkalinity as CaCO3	mg/l	50	50	80	200	154	133	180	186	30
Bicarbonate as HCO3	mg/l	8	8	98	220	172	140	203	217	43
Carbonate as CO3	mg/l	8	7	<1	11	8	7	11	11	3
Chloride	mg/l	50	49	<1	5	1	1	2	2	1
Fluoride	mg/l	50	1	<0.1	0.4	--	--	--	--	--
Sulfate	mg/l	50	50	2	9	5	4	6	8	2
Total Hardness	mg/l	49	48	<7	202	151	127	174	194	32
Calcium (DIS)	mg/l	50	50	21	58	43	36	50	55	9
Magnesium (DIS)	mg/l	50	50	5	15	11	9	13	14	2
Potassium (DIS)	mg/l	50	50	1	3	1	1	1	1	0
Sodium (DIS)	mg/l	50	46	<1	1	2	2	2	2	0
Nitrate + Nitrite as n	mg/l	50	23	<0.01	0.12	0.06	0.03	0.09	0.12	0.04
Nitrogen, Total (Calc)	mg/l	9	4	<0.5	3.6	2.9	2.5	3.2	3.5	0.6
Total Kjeldahl Nitrogen as n	mg/l	10	4	<0.5	3.6	2.9	2.4	3.2	3.5	0.6
Total Persulfate Nitrogen	mg/l	25	22	<0.04	1.39	0.21	0.06	0.16	0.74	0.31
Phosphorus (TOT)	mg/l	34	30	0.003	0.182	0.020	0.006	0.019	0.053	0.033
Aluminum (DIS)	mg/l	50	21	<0.009	0.39	0.09	0.02	0.11	0.30	0.11
Aluminum (TRC)	mg/l	8	8	0.05	2.65	0.48	0.07	0.38	1.86	0.89
Antimony (DIS)	mg/l	5	0	<0.003	--	--	--	--	--	--
Antimony (TRC)	mg/l	49	0	<0.003	--	--	--	--	--	--
Arsenic (DIS)	mg/l	5	0	<0.003	--	--	--	--	--	--
Arsenic (TRC)	mg/l	49	1	<0.001	0.001	--	--	--	--	--
Barium (DIS)	mg/l	5	5	0.077	0.087	0.081	0.077	0.081	0.086	0.004
Barium (TRC)	mg/l	49	49	0.07	0.128	0.09	0.09	0.10	0.11	0.01
Beryllium (DIS)	mg/l	5	0	<0.0008	--	--	--	--	--	--
Beryllium (TRC)	mg/l	49	0	<0.0008	--	--	--	--	--	--
Cadmium (DIS)	mg/l	5	0	0	--	--	--	--	--	--
Cadmium (TRC)	mg/l	49	4	0.00003	0.00006	0.00005	0.00003	0.00006	0.00006	0.00002
Chromium (DIS)	mg/l	5	0	<0.001	--	--	--	--	--	--
Chromium (TRC)	mg/l	49	1	<0.001	0.006	--	--	--	--	--
Cobalt (DIS)	mg/l	5	0	<0.01	--	--	--	--	--	--
Cobalt (TRC)	mg/l	49	0	<0.01	--	--	--	--	--	--
Copper (DIS)	mg/l	5	0	<0.001	--	--	--	--	--	--
Copper (TRC)	mg/l	49	6	<0.001	0.004	0.003	0.002	0.003	0.004	0.001
Iron (DIS)	mg/l	5	2	<0.03	0.04	0.04	0.04	0.04	0.04	0.00
Iron (TRC)	mg/l	49	49	0.09	2.49	0.34	0.13	0.31	1.12	0.43
Lead (DIS)	mg/l	5	0	<0.0003	--	--	--	--	--	--
Lead (TRC)	mg/l	49	12	<0.0003	0.0017	0.0006	0.0004	0.0007	0.0013	0.0004
Manganese (DIS)	mg/l	5	3	<0.005	0.014	0.009	0.007	0.011	0.013	0.004
Manganese (TRC)	mg/l	49	49	0.006	0.116	0.0150	0.0090	0.0140	0.0282	0.0166
Mercury (DIS)	mg/l	6	0	<0.00001	--	--	--	--	--	--
Mercury (TRC)	mg/l	49	9	<0.00001	0.00002	0.00001	0.00001	0.00001	0.00002	0.00000
Molybdenum (DIS)	mg/l	5	0	<0.005	--	--	--	--	--	--
Molybdenum (TRC)	mg/l	49	0	<0.005	--	--	--	--	--	--
Nickel (DIS)	mg/l	5	0	<0.01	--	--	--	--	--	--
Nickel (TRC)	mg/l	49	10	<0.001	0.002	0.002	0.001	0.002	0.002	0.001
Selenium (DIS)	mg/l	5	0	<0.001	--	--	--	--	--	--
Selenium (TRC)	mg/l	49	0	<0.001	--	--	--	--	--	--
Silver (DIS)	mg/l	5	0	<0.0005	--	--	--	--	--	--
Silver (TRC)	mg/l	49	0	<0.0002	--	--	--	--	--	--
Strontium (DIS)	mg/l	5	3	<0.1	0.1	0.1	0.1	0.1	0.1	0.0
Strontium (TRC)	mg/l	49	46	0.0818	0.15	0.12	0.11	0.13	0.14	0.01
Thallium (DIS)	mg/l	5	0	<0.0002	--	--	--	--	--	--
Thallium (TRC)	mg/l	49	0	<0.0002	--	--	--	--	--	--
Uranium (DIS)	mg/l	5	3	<0.0003	0.0004	0.0003	0.0003	0.0004	0.0004	0.0001
Uranium (TRC)	mg/l	49	7	<0.0003	0.0004	0.0003	0.0003	0.0004	0.0004	0.0001
Zinc (DIS)	mg/l	5	0	<0.01	--	--	--	--	--	--
Zinc (TRC)	mg/l	49	16	<0.01	0.014	0.006	0.004	0.007	0.014	0.004

SW-3 - Statistical Analysis
Reporting Period - 5/2011 - 12/2016

Parameter	Units	No. Samples	No. Detects	Min.	Max.	Mean	25% PCTL	75% PCTL	95% PCTL	SD.
Flow	Cubic Ft Sec	--	--	0.069	4.9	0.4	0.1	0.3	1.0	1.1
pH - Field	s.u.	--	--	8.02	8.70	8.29	8.19	8.38	8.52	0.15
Specific Conductance	umhos/cm	--	--	269	408	372	363	393	407	36
Water Temperature	Deg C	--	--	0.01	14.5	8.2	4.5	12.1	13.8	4.9
Dissolved Oxygen	mg/l	--	--	5.95	12.82	9.7	9.2	10.8	11.7	1.5
Total Dissolved Solids	mg/l	21	21	152	231	213	207	224	229	17
Total Suspended Solids	mg/l	18	7	<4	14	9	6	12	14	4
Alkalinity as CaCO3	mg/l	21	21	150	210	197	200	200	210	12
Bicarbonate as HCO3	mg/l	7	7	180	240	224	225	235	240	21
Carbonate as CO3	mg/l	7	7	2	9	7	7	9	9	2
Chloride	mg/l	21	19	<1	2	1	1	2	2	0
Fluoride	mg/l	21	21	0.1	0.2	0.2	0.2	0.2	0.2	--
Sulfate	mg/l	21	21	5	23	14	12	18	23	5
Total Hardness	mg/l	20	20	139	225	206	201	219	225	20
Calcium (DIS)	mg/l	19	19	31	50	46	45	49	50	4
Magnesium (DIS)	mg/l	19	19	15	25	22	22	24	25	2
Potassium (DIS)	mg/l	19	19	2	2	1	1	1	1	0
Sodium (DIS)	mg/l	19	16	<1	1	2	2	2	2	0
Nitrate + Nitrite as n	mg/l	21	19	<0.01	0.12	0.06	0.05	0.07	0.12	0.03
Nitrogen, Total (Calc)	mg/l	3	1	<0.5	2.3	--	--	--	--	--
Total Kjeldahl Nitrogen as n	mg/l	3	1	<0.5	2.2	--	--	--	--	--
Total Persulfate Nitrogen	mg/l	8	7	<0.04	0.22	0.15	0.11	0.17	0.21	0.04
Phosphorus (TOT)	mg/l	11	10	0.008	0.02	0.01	0.01	0.01	0.02	0.00
Aluminum (DIS)	mg/l	19	2	<0.009	0.07	0.04	0.02	0.05	0.07	0.04
Aluminum (TRC)	mg/l	6	5	<0.03	0.72	0.38	0.11	0.68	0.71	0.30
Antimony (DIS)	mg/l	3	0	<0.003	--	--	--	--	--	--
Antimony (TRC)	mg/l	21	0	<0.003	--	--	--	--	--	--
Arsenic (DIS)	mg/l	3	0	<0.003	--	--	--	--	--	--
Arsenic (TRC)	mg/l	21	0	<0.001	--	--	--	--	--	--
Barium (DIS)	mg/l	3	3	0.12	0.14	0.13	0.12	0.13	0.14	0.01
Barium (TRC)	mg/l	21	21	0.122	0.168	0.148	0.138	0.156	0.168	0.013
Beryllium (DIS)	mg/l	3	0	<0.001	--	--	--	--	--	--
Beryllium (TRC)	mg/l	21	0	<0.0008	--	--	--	--	--	--
Cadmium (DIS)	mg/l	3	0	<0.00008	--	--	--	--	--	--
Cadmium (TRC)	mg/l	21	0	<0.00003	--	--	--	--	--	--
Chromium (DIS)	mg/l	3	0	<0.001	--	--	--	--	--	--
Chromium (TRC)	mg/l	21	0	<0.001	--	--	--	--	--	--
Cobalt (DIS)	mg/l	3	0	<0.01	--	--	--	--	--	--
Cobalt (TRC)	mg/l	21	0	<0.01	--	--	--	--	--	--
Copper (DIS)	mg/l	3	0	<0.001	--	--	--	--	--	--
Copper (TRC)	mg/l	21	5	<0.001	0.003	0.002	0.001	0.002	0.003	0.001
Iron (DIS)	mg/l	3	0	<0.03	--	--	--	--	--	--
Iron (TRC)	mg/l	21	21	0.05	1.08	0.25	0.10	0.23	0.86	0.27
Lead (DIS)	mg/l	3	0	<0.0005	--	--	--	--	--	--
Lead (TRC)	mg/l	21	13	<0.0003	0.0031	0.0010	0.0004	0.0010	0.0029	0.0009
Manganese (DIS)	mg/l	3	0	<0.005	--	--	--	--	--	--
Manganese (TRC)	mg/l	21	8	<0.005	0.028	0.013	0.007	0.021	0.026	0.009
Mercury (DIS)	mg/l	5	1	<0.00001	0.00001	--	--	--	--	--
Mercury (TRC)	mg/l	21	2	<0.00001	0.00001	0.00001	0.00001	0.00001	0.00001	0.00000
Molybdenum (DIS)	mg/l	3	0	<0.005	--	--	--	--	--	--
Molybdenum (TRC)	mg/l	21	0	<0.002	--	--	--	--	--	--
Nickel (DIS)	mg/l	3	0	<0.01	--	--	--	--	--	--
Nickel (TRC)	mg/l	21	0	<0.001	--	--	--	--	--	--
Selenium (DIS)	mg/l	3	0	<0.001	--	--	--	--	--	--
Selenium (TRC)	mg/l	21	3	<0.0002	0.0003	0.0002	0.0002	0.0003	0.0003	0.0001
Silver (DIS)	mg/l	3	0	<0.0005	--	--	--	--	--	--
Silver (TRC)	mg/l	21	0	<0.0002	--	--	--	--	--	--
Strontium (DIS)	mg/l	3	0	<0.1	--	--	--	--	--	--
Strontium (TRC)	mg/l	21	18	0.0838	0.119	0.105	0.100	0.110	0.118	0.009
Thallium (DIS)	mg/l	3	0	<0.0002	--	--	--	--	--	--
Thallium (TRC)	mg/l	21	3	<0.0002	0.0004	0.0003	0.0003	0.0004	0.0004	0.0001
Uranium (DIS)	mg/l	3	3	0.0005	0.0006	0.0006	0.0006	0.0006	0.0006	0.0001
Uranium (TRC)	mg/l	21	9	0.0005	0.0007	0.0006	0.0006	0.0007	0.0007	0.0001
Zinc (DIS)	mg/l	3	0	<0.01	--	--	--	--	--	--
Zinc (TRC)	mg/l	21	10	<0.002	0.004	0.003	0.003	0.003	0.004	0.001

SW-4 - Statistical Analysis
Reporting Period - 5/2011 - 12/2016

Parameter	Units	No. Samples	No. Detects	Min.	Max.	Mean	25% PCTL	75% PCTL	95% PCTL	SD.
Flow	Cubic Ft Sec	--	--	--	2.0	0.2	0.0	0.1	0.5	0.5
pH - Field	s.u.	--	--	7.55	8.68	8.04	7.90	8.21	8.33	0.24
Specific Conductance	umhos/cm	--	--	237	390	355	353	375	386	35
Water Temperature	Deg C	--	--	0.08	15	7.9	2.2	12.7	14.2	5.4
Dissolved Oxygen	mg/l	--	--	5.39	12.57	9.2	8.4	10.1	12.3	1.7

SW-5 - Statistical Analysis
Reporting Period - 5/2011 - 12/2016

Parameter	Units	No. Samples	No. Detects	Min.	Max.	Mean	25% PCTL	75% PCTL	95% PCTL	SD.
Flow	Cubic Ft Sec	--	--	0.48	4.7	1.6	0.6	1.7	4.1	2.0
pH - Field	s.u.	--	--	7.29	8.18	7.63	7.47	7.69	8.08	0.38
Specific Conductance	umhos/cm	--	--	49	60	54	50	56	59	5
Water Temperature	Deg C	--	--	2.9	12.1	7.4	5.9	8.9	11.5	3.8
Dissolved Oxygen	mg/l	--	--	8.52	11.35	9.73	9.18	10.08	11.10	1.18
Total Dissolved Solids	mg/l	4	4	66	102	82	72	90	100	16
Total Suspended Solids	mg/l	3	1	<10	25	--	--	--	--	--
Alkalinity as CaCO3	mg/l	4	4	24	27	26	26	27	27	1
Bicarbonate as HCO3	mg/l	2	2	32	33	33	32	33	33	1
Carbonate as CO3	mg/l	2	0	<1	--	--	--	--	--	--
Chloride	mg/l	4	0	<1	--	--	--	--	--	--
Fluoride	mg/l	4	0	<0.1	--	--	--	--	--	--
Sulfate	mg/l	4	2	<1	2	2	1	2	2	1
Total Hardness	mg/l	4	4	19	26	24	24	26	26	4
Calcium (DIS)	mg/l	4	4	6	7	7	7	7	7	1
Magnesium (DIS)	mg/l	4	4	1	2	2	2	2	2	1
Potassium (DIS)	mg/l	4	4	1	2	2	1	2	2	1
Sodium (DIS)	mg/l	4	4	1	1	1	1	1	1	0
Nitrate + Nitrite as n	mg/l	4	3	<0.01	0.06	0.04	0.03	0.05	0.06	0.03
Nitrogen, Total (Calc)	mg/l	1	1	0.7	0.7	--	--	--	--	--
Total Kjeldahl Nitrogen as n	mg/l	1	1	0.7	0.7	--	--	--	--	--
Phosphorus (TOT)	mg/l	1	1	0.04	0.04	--	--	--	--	--
Aluminum (DIS)	mg/l	4	4	0.19	2.09	0.85	0.36	1.04	1.88	0.85
Aluminum (TRC)	mg/l	2	2	0.68	0.99	0.84	0.76	0.91	0.97	0.22
Antimony (DIS)	mg/l	1	0	<0.003	--	--	--	--	--	--
Antimony (TRC)	mg/l	4	0	<0.003	--	--	--	--	--	--
Arsenic (DIS)	mg/l	1	0	<0.003	--	--	--	--	--	--
Arsenic (TRC)	mg/l	4	2	<0.003	0.002	0.002	0.001	0.002	0.002	0.001
Barium (DIS)	mg/l	1	1	0.154	0.154	--	--	--	--	--
Barium (TRC)	mg/l	4	4	0.157	0.214	0.185	0.177	0.192	0.210	0.023
Beryllium (DIS)	mg/l	1	0	<0.001	--	--	--	--	--	--
Beryllium (TRC)	mg/l	4	0	<0.0008	--	--	--	--	--	--
Cadmium (DIS)	mg/l	1	0	<0.00008	--	--	--	--	--	--
Cadmium (TRC)	mg/l	4	0	<0.00003	--	--	--	--	--	--
Chromium (DIS)	mg/l	1	0	<0.001	--	--	--	--	--	--
Chromium (TRC)	mg/l	4	1	<0.001	0.001	--	--	--	--	--
Cobalt (DIS)	mg/l	1	0	<0.01	--	--	--	--	--	--
Cobalt (TRC)	mg/l	4	0	<0.01	--	--	--	--	--	--
Copper (DIS)	mg/l	1	1	0.002	0.002	--	--	--	--	--
Copper (TRC)	mg/l	4	4	0.003	0.004	0.003	0.003	0.003	0.004	0.001
Iron (DIS)	mg/l	1	1	0.18	0.18	--	--	--	--	--
Iron (TRC)	mg/l	4	4	0.47	1.9	1.1	0.7	1.5	1.8	0.6
Lead (DIS)	mg/l	1	0	<0.0005	--	--	--	--	--	--
Lead (TRC)	mg/l	4	2	<0.0005	0.0007	0.0006	0.0006	0.0007	0.0007	0.0001
Manganese (DIS)	mg/l	1	1	0.019	0.019	--	--	--	--	--
Manganese (TRC)	mg/l	4	4	0.011	0.037	0.019	0.013	0.020	0.034	0.012
Mercury (DIS)	mg/l	1	1	0.00001	0.00001	--	--	--	--	--
Mercury (TRC)	mg/l	4	3	6.20E-06	0.000012	0.000009	0.000008	0.000011	0.000012	0.000003
Molybdenum (DIS)	mg/l	1	0	<0.005	--	--	--	--	--	--
Molybdenum (TRC)	mg/l	4	0	<0.002	--	--	--	--	--	--
Nickel (DIS)	mg/l	1	0	<0.01	--	--	--	--	--	--
Nickel (TRC)	mg/l	4	2	0.003	0.004	0.004	0.003	0.004	0.004	0.001
Selenium (DIS)	mg/l	1	0	<0.001	--	--	--	--	--	--
Selenium (TRC)	mg/l	4	1	<0.0002	0.0002	--	--	--	--	--
Silver (DIS)	mg/l	1	0	<0.0005	--	--	--	--	--	--
Silver (TRC)	mg/l	4	0	<0.0005	--	--	--	--	--	--
Strontium (DIS)	mg/l	1	0	<0.1	--	--	--	--	--	--
Strontium (TRC)	mg/l	4	2	0.028	0.0296	0.029	0.028	0.029	0.030	0.001
Thallium (DIS)	mg/l	1	0	<0.0002	--	--	--	--	--	--
Thallium (TRC)	mg/l	4	0	<0.0002	--	--	--	--	--	--
Uranium (DIS)	mg/l	1	0	<0.0003	--	--	--	--	--	--
Uranium (TRC)	mg/l	4	0	<0.008	--	--	--	--	--	--
Zinc (DIS)	mg/l	1	0	<0.01	--	--	--	--	--	--
Zinc (TRC)	mg/l	4	3	0.007	0.015	0.011	0.009	0.013	0.015	0.004

SW-6 - Statistical Analysis
Reporting Period - 5/2011 - 12/2016

Parameter	Units	No. Samples	No. Detects	Min.	Max.	Mean	25% PCTL	75% PCTL	95% PCTL	SD.
Flow	Cubic Ft Sec	--	--	0.04	4.1	0.4	0.1	0.3	1.1	0.9
pH - Field	s.u.	--	--	6.67	8.68	8.03	7.97	8.24	8.55	0.46
Specific Conductance	umhos/cm	--	--	249	433	387	371	411	419	38
Water Temperature	Deg C	--	--	0.01	18.3	8.5	2.1	14.5	16.3	6.3
Dissolved Oxygen	mg/l	--	--	5.82	14.18	9.39	8.41	10.55	11.49	1.87
Total Dissolved Solids	mg/l	22	22	162	254	219	213	232	247	20
Total Suspended Solids	mg/l	17	12	<10	107	28	10	23	102	35
Alkalinity as CaCO3	mg/l	22	22	140	240	214	210	228	230	21
Bicarbonate as HCO3	mg/l	7	7	220	260	246	245	250	257	13
Carbonate as CO3	mg/l	7	7	4	13	9	7	12	13	3
Chloride	mg/l	22	8	<1	2	1	1	1	2	0
Fluoride	mg/l	22	20	<0.1	0.2	0.2	0.1	0.2	0.2	0.0
Sulfate	mg/l	22	22	6	18	10	8	13	15	3
Total Hardness	mg/l	22	22	119	231	210	210	225	230	26
Calcium (DIS)	mg/l	21	21	28	54	49	49	52	53	6
Magnesium (DIS)	mg/l	21	21	12	24	21	21	23	24	3
Potassium (DIS)	mg/l	21	21	2	3	1	1	1	3	1
Sodium (DIS)	mg/l	21	9	<1	3	3	3	3	3	0
Nitrate + Nitrite as n	mg/l	22	20	<0.01	0.11	0.06	0.03	0.09	0.10	0.03
Nitrogen, Total (Calc)	mg/l	4	1	<0.5	3.46	--	--	--	--	--
Total Kjeldahl Nitrogen as n	mg/l	4	1	<0.5	3.4	--	--	--	--	--
Total Persulfate Nitrogen	mg/l	6	6	0.13	0.39	0.20	0.14	0.19	0.34	0.10
Phosphorus (TOT)	mg/l	10	10	0.01	0.044	0.02	0.02	0.02	0.03	0.01
Aluminum (DIS)	mg/l	21	1	<0.009	0.012	--	--	--	--	--
Aluminum (TRC)	mg/l	7	7	0.03	0.20	0.13	0.11	0.16	0.19	0.05
Antimony (DIS)	mg/l	4	0	<0.003	--	--	--	--	--	--
Antimony (TRC)	mg/l	21	0	<0.0005	--	--	--	--	--	--
Arsenic (DIS)	mg/l	4	0	<0.003	--	--	--	--	--	--
Arsenic (TRC)	mg/l	21	0	<0.001	--	--	--	--	--	--
Barium (DIS)	mg/l	4	4	0.107	0.125	0.119	0.118	0.124	0.125	0.008
Barium (TRC)	mg/l	21	21	0.091	0.247	0.132	0.120	0.137	0.160	0.030
Beryllium (DIS)	mg/l	4	0	<0.001	--	--	--	--	--	--
Beryllium (TRC)	mg/l	21	0	<0.0008	--	--	--	--	--	--
Cadmium (DIS)	mg/l	4	0	<0.00008	--	--	--	--	--	--
Cadmium (TRC)	mg/l	21	2	<0.00003	0.00005	0.00004	0.00004	0.00005	0.00005	0.00001
Chromium (DIS)	mg/l	4	0	<0.001	--	--	--	--	--	--
Chromium (TRC)	mg/l	21	0	<0.005	--	--	--	--	--	--
Cobalt (DIS)	mg/l	4	0	<0.005	--	--	--	--	--	--
Cobalt (TRC)	mg/l	21	0	<0.005	--	--	--	--	--	--
Copper (DIS)	mg/l	4	0	<0.001	--	--	--	--	--	--
Copper (TRC)	mg/l	21	1	<0.001	0.001	--	--	--	--	--
Iron (DIS)	mg/l	4	2	<0.03	0.04	0.04	0.04	0.04	0.04	0.00
Iron (TRC)	mg/l	21	21	0.05	1.85	0.45	0.23	0.48	0.83	0.38
Lead (DIS)	mg/l	4	0	<0.0005	--	--	--	--	--	--
Lead (TRC)	mg/l	21	10	<0.0003	0.0023	0.0007	0.0004	0.0007	0.0016	0.0006
Manganese (DIS)	mg/l	4	4	0.005	0.012	0.007	0.005	0.008	0.011	0.003
Manganese (TRC)	mg/l	21	19	<0.005	0.067	0.021	0.014	0.023	0.040	0.013
Mercury (DIS)	mg/l	5	0	<0.00001	--	--	--	--	--	--
Mercury (TRC)	mg/l	21	4	<0.000005	0.00002	0.00001	0.00001	0.00002	0.00002	0.00000
Molybdenum (DIS)	mg/l	4	0	<0.005	--	--	--	--	--	--
Molybdenum (TRC)	mg/l	21	0	<0.002	--	--	--	--	--	--
Nickel (DIS)	mg/l	4	0	<0.01	--	--	--	--	--	--
Nickel (TRC)	mg/l	21	2	<0.001	0.001	0.001	0.001	0.001	0.001	0.000
Selenium (DIS)	mg/l	4	0	<0.001	--	--	--	--	--	--
Selenium (TRC)	mg/l	21	7	<0.0002	0.0005	0.0003	0.0002	0.0003	0.0004	0.0001
Silver (DIS)	mg/l	4	0	<0.0005	--	--	--	--	--	--
Silver (TRC)	mg/l	21	0	<0.0005	--	--	--	--	--	--
Strontium (DIS)	mg/l	4	4	0.10	0.20	0.2	0.2	0.2	0.2	0.1
Strontium (TRC)	mg/l	21	21	0.10	0.329	0.17	0.15	0.18	0.20	0.05
Thallium (DIS)	mg/l	4	0	<0.0002	--	--	--	--	--	--
Thallium (TRC)	mg/l	21	0	<0.0002	--	--	--	--	--	--
Uranium (DIS)	mg/l	4	4	0.0006	0.0007	0.0007	0.0006	0.0007	0.0007	0.0001
Uranium (TRC)	mg/l	21	10	0.0005	0.0007	0.0006	0.0006	0.0007	0.0007	0.0001
Zinc (DIS)	mg/l	4	0	<0.01	--	--	--	--	--	--
Zinc (TRC)	mg/l	21	9	<0.002	0.008	0.004	0.003	0.006	0.007	0.002

SW-7 - Statistical Analysis
Reporting Period - 5/2011 - 12/2016

Parameter	Units	No. Samples	No. Detects	Min.	Max.	Mean	25% PCTL	75% PCTL	95% PCTL	SD.
Flow	gallons per min	--	--	--	128	13	1	15	26	26
pH - Field	s.u.	--	--	6.79	8.30	7.68	7.66	7.88	7.99	0.42
Specific Conductance	umhos/cm	--	--	359	424	397	392	411	416	22
Water Temperature	Deg C	--	--	0.6	15.1	8.4	6.0	10.9	13.5	3.4
Dissolved Oxygen	mg/l	--	--	7.18	12.86	8.84	7.96	9.98	11.21	1.88
Total Dissolved Solids	mg/l	10	10	201	228	219	212	226	235	12
Total Suspended Solids	mg/l	10	2	<10	48	39	34	43	47	13
Alkalinity as CaCO3	mg/l	10	10	200	220	215	213	220	220	8
Bicarbonate as HCO3	mg/l	1	1	270	270	--	--	--	--	--
Carbonate as CO3	mg/l	1	1	1	1	--	--	--	--	--
Chloride	mg/l	10	1	<1	2	--	--	--	--	--
Fluoride	mg/l	10	9	<0.1	0.1	0.1	0.1	0.1	0.1	0.0
Sulfate	mg/l	10	10	6	7	9	7	10	11	2
Total Hardness	mg/l	10	10	193	223	222	210	237	242	17
Calcium (DIS)	mg/l	10	10	51	58	58	56	62	63	4
Magnesium (DIS)	mg/l	10	10	16	19	19	17	20	21	2
Potassium (DIS)	mg/l	10	1	<1	1	--	--	--	--	--
Sodium (DIS)	mg/l	10	10	2	2	2	2	2	2	0
Nitrate + Nitrite as n	mg/l	10	8	0.02	0.13	0.05	0.03	0.05	0.11	0.04
Nitrogen, Total (Calc)	mg/l	1	0	<0.5	--	--	--	--	--	--
Total Kjeldahl Nitrogen as n	mg/l	1	0	<0.5	--	--	--	--	--	--
Total Persulfate Nitrogen	mg/l	1	1	0.24	0.24	--	--	--	--	--
Phosphorus (TOT)	mg/l	2	2	0.005	0.02	0.01	0.01	0.02	0.02	0.01
Aluminum (DIS)	mg/l	10	0	<0.009	--	--	--	--	--	--
Antimony (DIS)	mg/l	6	0	<0.0005	--	--	--	--	--	--
Antimony (TRC)	mg/l	4	0	<0.0005	--	--	--	--	--	--
Arsenic (DIS)	mg/l	6	0	<0.001	--	--	--	--	--	--
Arsenic (TRC)	mg/l	4	0	<0.001	--	--	--	--	--	--
Barium (DIS)	mg/l	4	4	0.048	0.061	0.054	0.050	0.059	0.061	0.006
Barium (TRC)	mg/l	4	4	0.048	0.061	0.054	0.050	0.059	0.061	0.006
Beryllium (DIS)	mg/l	6	0	<0.0008	--	--	--	--	--	--
Beryllium (TRC)	mg/l	4	0	<0.0008	--	--	--	--	--	--
Cadmium (DIS)	mg/l	6	0	<0.00003	--	--	--	--	--	--
Cadmium (TRC)	mg/l	4	1	<0.00003	0.00006	--	--	--	--	--
Chromium (DIS)	mg/l	6	0	<0.01	--	--	--	--	--	--
Chromium (TRC)	mg/l	4	1	0.001	0.001	--	--	--	--	--
Cobalt (DIS)	mg/l	6	0	<0.01	--	--	--	--	--	--
Cobalt (TRC)	mg/l	4	0	<0.01	--	--	--	--	--	--
Copper (DIS)	mg/l	6	0	<0.002	--	--	--	--	--	--
Copper (TRC)	mg/l	4	1	<0.002	0.002	--	--	--	--	--
Iron (DIS)	mg/l	6	0	<0.02	--	--	--	--	--	--
Iron (TRC)	mg/l	4	3	<0.02	0.64	0.27	0.08	0.39	0.59	0.33
Lead (DIS)	mg/l	6	0	<0.0003	--	--	--	--	--	--
Lead (TRC)	mg/l	4	1	<0.0003	0.0009	--	--	--	--	--
Manganese (DIS)	mg/l	6	2	<0.005	--	--	--	--	--	--
Manganese (TRC)	mg/l	4	2	<0.005	0.02	0.01	0.01	0.02	0.02	0.01
Mercury (DIS)	mg/l	6	0	<0.000005	--	--	--	--	--	--
Mercury (TRC)	mg/l	4	0	<0.000005	--	--	--	--	--	--
Molybdenum (DIS)	mg/l	6	0	<0.002	--	--	--	--	--	--
Molybdenum (TRC)	mg/l	4	0	<0.005	--	--	--	--	--	--
Nickel (DIS)	mg/l	6	0	<0.001	--	--	--	--	--	--
Nickel (TRC)	mg/l	4	0	<0.001	--	--	--	--	--	--
Selenium (DIS)	mg/l	6	0	<0.0002	--	--	--	--	--	--
Selenium (TRC)	mg/l	4	1	<0.0002	0.0002	--	--	--	--	--
Silver (DIS)	mg/l	6	0	<0.02	--	--	--	--	--	--
Silver (TRC)	mg/l	4	0	<0.02	--	--	--	--	--	--
Strontium (DIS)	mg/l	6	6	0.121	0.146	0.137	0.137	0.141	0.145	0.009
Strontium (TRC)	mg/l	4	4	0.119	0.13	0.127	0.126	0.131	0.132	0.006
Thallium (DIS)	mg/l	6	0	<0.0002	--	--	--	--	--	--
Thallium (TRC)	mg/l	4	0	<0.0002	--	--	--	--	--	--
Uranium (DIS)	mg/l	6	0	<0.008	--	--	--	--	--	--
Uranium (TRC)	mg/l	4	1	<0.008	0.0009	--	--	--	--	--
Zinc (DIS)	mg/l	6	0	<0.002	--	--	--	--	--	--
Zinc (TRC)	mg/l	4	1	<0.002	0.01	--	--	--	--	--

SW-8 - Statistical Analysis
Reporting Period - 5/2011 - 12/2016

Parameter	Units	No. Samples	No. Detects	Min.	Max.	Mean	25% PCTL	75% PCTL	95% PCTL	SD.
Flow	Cubic Ft Sec	--	--	--	9.1	1.6	0.2	1.2	6.6	2.5
pH - Field	s.u.	--	--	6.90	8.69	7.88	7.75	8.11	8.33	0.40
Specific Conductance	umhos/cm	--	--	164	443	378	338	431	441	79
Water Temperature	Deg C	--	--	0.0	15.7	6.6	1.4	9.6	14.2	5.2
Dissolved Oxygen	mg/l	--	--	5.61	12.76	9.98	9.36	11.02	12.60	1.62

SW-9 - Statistical Analysis
Reporting Period - 5/2011 - 12/2016

Parameter	Units	No. Samples	No. Detects	Min.	Max.	Mean	25% PCTL	75% PCTL	95% PCTL	SD.
Flow	Cubic Ft Sec	--	--	--	12.7	1.5	0.4	1.3	2.5	2.7
pH - Field	s.u.	--	--	7.73	8.51	8.17	8.09	8.26	8.40	0.18
Specific Conductance	umhos/cm	--	--	335	443	418	418	435	441	27
Water Temperature	Deg C	--	--	0.5	14.9	6.4	1.8	10.7	13.4	4.9
Dissolved Oxygen	mg/l	--	--	5.73	12.63	10.11	9.28	11.05	11.65	1.54

SW-10 - Statistical Analysis
Reporting Period - 5/2011 - 12/2016

Parameter	Units	No. Samples	No. Detects	Min.	Max.	Mean	25% PCTL	75% PCTL	95% PCTL	SD.
Flow	Cubic Ft Sec	--	--	0.17	15.2	1.7	0.4	1.5	5.2	3.7
pH - Field	s.u.	--	--	8.01	8.75	8.35	8.24	8.49	8.64	0.20
Specific Conductance	umhos/cm	--	--	353	438	415	414	425	436	19
Water Temperature	Deg C	--	--	0.02	18.6	9.3	5.1	15.4	18.6	6.7
Dissolved Oxygen	mg/l	--	--	6.63	12.27	9.97	9.01	10.97	11.34	1.46
Total Dissolved Solids	mg/l	2	2	236	249	243	239	246	248	9
Total Suspended Solids	mg/l	2	2	6	38	22	14	30	36	23
Alkalinity as CaCO3	mg/l	2	2	210	220	215	213	218	220	7
Chloride	mg/l	2	0	<1	--	--	--	--	--	--
Fluoride	mg/l	2	2	0.2	0.2	0	0	0	0	0
Sulfate	mg/l	2	2	15	19	17	16	18	19	3
Total Hardness	mg/l	2	2	220	220	220	220	220	220	0
Calcium (DIS)	mg/l	2	2	50	52	51	51	52	52	1
Magnesium (DIS)	mg/l	2	2	22	23	23	22	23	23	1
Potassium (DIS)	mg/l	2	1	<1	1	--	--	--	--	--
Sodium (DIS)	mg/l	2	2	2	2	2	2	2	2	0
Nitrate + Nitrite as n	mg/l	2	2	0.1	0.12	0.11	0.11	0.12	0.12	0.01
Total Persulfate Nitrogen	mg/l	2	2	0.21	0.42	0.32	0.26	0.37	0.41	0.15
Phosphorus (TOT)	mg/l	2	2	0.011	0.025	0.018	0.015	0.022	0.024	0.010
Aluminum (DIS)	mg/l	2	0	<0.009	--	--	--	--	--	--
Antimony (TRC)	mg/l	2	0	<0.0005	--	--	--	--	--	--
Arsenic (TRC)	mg/l	2	0	<0.001	--	--	--	--	--	--
Barium (TRC)	mg/l	2	2	0.077	0.089	0.083	0.080	0.086	0.088	0.008
Beryllium (TRC)	mg/l	2	0	<0.0008	--	--	--	--	--	--
Cadmium (TRC)	mg/l	2	1	<0.00003	0.00004	--	--	--	--	--
Chromium (TRC)	mg/l	2	0	<0.01	--	--	--	--	--	--
Cobalt (TRC)	mg/l	2	0	<0.01	--	--	--	--	--	--
Copper (TRC)	mg/l	2	0	<0.002	--	--	--	--	--	--
Iron (TRC)	mg/l	2	2	0.15	0.75	0.45	0.30	0.60	0.72	0.42
Lead (TRC)	mg/l	2	1	<0.0003	0.0011	--	--	--	--	--
Manganese (TRC)	mg/l	2	2	0.01	0.021	0.02	0.01	0.02	0.02	0.01
Mercury (TRC)	mg/l	2	0	<0.000005	--	--	--	--	--	--
Molybdenum (TRC)	mg/l	2	0	<0.002	--	--	--	--	--	--
Nickel (TRC)	mg/l	2	0	<0.001	--	--	--	--	--	--
Selenium (TRC)	mg/l	2	0	<0.0002	--	--	--	--	--	--
Silver (TRC)	mg/l	2	0	<0.02	--	--	--	--	--	--
Strontium (TRC)	mg/l	2	2	0.191	0.209	0.200	0.196	0.205	0.208	0.013
Thallium (TRC)	mg/l	2	0	<0.0002	--	--	--	--	--	--
Uranium (TRC)	mg/l	2	0	<0.008	--	--	--	--	--	--
Zinc (TRC)	mg/l	2	2	0.003	0.008	0.006	0.004	0.007	0.008	0.004

SW-11 - Statistical Analysis
Reporting Period - 5/2011 - 12/2016

Parameter	Units	No. Samples	No. Detects	Min.	Max.	Mean	25% PCTL	75% PCTL	95% PCTL	SD.
Flow	Cubic Ft Sec	--	--	0.31	21.4	2.4	0.4	1.6	7.5	5.0
pH - Field	s.u.	--	--	7.53	8.69	8.25	8.14	8.44	8.59	0.27
Specific Conductance	umhos/cm	--	--	312	487	403	388	425	453	39
Water Temperature	Deg C	--	--	-0.02	16.3	6.7	0.3	12.1	16.3	5.9
Dissolved Oxygen	mg/l	--	--	7.03	15.4	10.9	9.1	11.9	14.1	2.0
Total Dissolved Solids	mg/l	23	23	166	280	227	218	240	258	25
Total Suspended Solids	mg/l	19	6	<4	47	22	13	25	42	14
Alkalinity as CaCO3	mg/l	23	23	160	250	207	200	220	230	21
Bicarbonate as HCO3	mg/l	6	6	210	260	238	225	250	258	19
Carbonate as CO3	mg/l	6	6	4	12	9	7	12	12	3
Chloride	mg/l	23	19	<1	2	1	1	2	2	0
Fluoride	mg/l	23	23	0.1	0.2	0.2	0.2	0.2	0.2	--
Sulfate	mg/l	23	23	9	33	19	14	24	29	7
Total Hardness	mg/l	23	23	156	257	217	201	236	249	28
Calcium (DIS)	mg/l	22	22	36	60	50	47	54	56	6
Magnesium (DIS)	mg/l	22	22	16	27	23	21	25	26	3
Potassium (DIS)	mg/l	22	22	2	3	1	1	1	1	0
Sodium (DIS)	mg/l	22	21	<1	2	3	2	3	3	1
Nitrate + Nitrite as n	mg/l	23	20	0.01	0.19	0.07	0.04	0.11	0.19	0.06
Nitrogen, Total (Calc)	mg/l	4	1	<0.5	3.4	--	--	--	--	--
Total Kjeldahl Nitrogen as n	mg/l	4	1	<0.5	3.4	--	--	--	--	--
Total Persulfate Nitrogen	mg/l	8	8	0.09	0.29	0.18	0.12	0.24	0.28	0.07
Phosphorus (TOT)	mg/l	12	12	0.012	0.06	0.03	0.02	0.03	0.04	0.01
Aluminum (DIS)	mg/l	22	4	<0.009	0.196	0.121	0.098	0.153	0.187	0.069
Aluminum (TRC)	mg/l	6	6	0.08	0.33	0.20	0.14	0.28	0.33	0.10
Antimony (DIS)	mg/l	3	0	<0.003	--	--	--	--	--	--
Antimony (TRC)	mg/l	21	0	<0.0005	--	--	--	--	--	--
Arsenic (DIS)	mg/l	3	0	<0.003	--	--	--	--	--	--
Arsenic (TRC)	mg/l	21	1	<0.001	0.001	--	--	--	--	--
Barium (DIS)	mg/l	3	3	0.092	0.113	0.105	0.101	0.111	0.113	0.011
Barium (TRC)	mg/l	21	21	0.09	0.13	0.11	0.10	0.11	0.13	0.01
Beryllium (DIS)	mg/l	3	0	<0.001	--	--	--	--	--	--
Beryllium (TRC)	mg/l	21	0	<0.0008	--	--	--	--	--	--
Cadmium (DIS)	mg/l	3	0	<0.00008	--	--	--	--	--	--
Cadmium (TRC)	mg/l	21	2	<0.00003	0.00004	0.00004	0.00003	0.00004	0.00004	0.00001
Chromium (DIS)	mg/l	3	0	<0.001	--	--	--	--	--	--
Chromium (TRC)	mg/l	21	0	<0.001	--	--	--	--	--	--
Cobalt (DIS)	mg/l	3	0	<0.01	--	--	--	--	--	--
Cobalt (TRC)	mg/l	21	0	<0.01	--	--	--	--	--	--
Copper (DIS)	mg/l	3	0	<0.001	--	--	--	--	--	--
Copper (TRC)	mg/l	21	4	<0.001	0.002	0.002	0.001	0.002	0.002	0.001
Iron (DIS)	mg/l	3	3	0.04	0.06	0.047	0.040	0.050	0.058	0.012
Iron (TRC)	mg/l	21	21	0.07	1.43	0.33	0.12	0.38	0.87	0.32
Lead (DIS)	mg/l	3	0	<0.0005	--	--	--	--	--	--
Lead (TRC)	mg/l	21	6	<0.0005	0.0018	0.0008	0.0005	0.0008	0.0016	0.0005
Manganese (DIS)	mg/l	3	1	<0.005	0.007	--	--	--	--	--
Manganese (TRC)	mg/l	21	14	<0.005	0.063	0.018	0.007	0.021	0.042	0.015
Mercury (DIS)	mg/l	4	0	<0.00001	--	--	--	--	--	--
Mercury (TRC)	mg/l	21	4	<0.00001	0.00002	0.00001	0.00001	0.00001	0.00002	0.00001
Molybdenum (DIS)	mg/l	3	0	<0.005	--	--	--	--	--	--
Molybdenum (TRC)	mg/l	21	0	<0.005	--	--	--	--	--	--
Nickel (DIS)	mg/l	3	0	<0.01	--	--	--	--	--	--
Nickel (TRC)	mg/l	21	2	<0.001	0.001	0.001	0.001	0.001	0.001	0.000
Selenium (DIS)	mg/l	3	0	<0.001	--	--	--	--	--	--
Selenium (TRC)	mg/l	21	2	<0.0002	0.0002	0.0002	0.0002	0.0002	0.0002	0.0000
Silver (DIS)	mg/l	3	0	<0.0005	--	--	--	--	--	--
Silver (TRC)	mg/l	21	0	<0.0005	--	--	--	--	--	--
Strontium (DIS)	mg/l	3	3	0.1	0.2	0.2	0.2	0.2	0.2	0.1
Strontium (TRC)	mg/l	21	21	0.1	0.2	0.2	0.2	0.2	0.2	0.0
Thallium (DIS)	mg/l	3	0	<0.0002	--	--	--	--	--	--
Thallium (TRC)	mg/l	21	0	<0.0002	--	--	--	--	--	--
Uranium (DIS)	mg/l	3	3	<0.008	0.0009	0.0008	0.0008	0.0009	0.0009	0.0001
Uranium (TRC)	mg/l	21	9	<0.008	0.0009	0.0009	0.0008	0.0009	0.0009	0.0001
Zinc (DIS)	mg/l	3	0	<0.01	--	--	--	--	--	--
Zinc (TRC)	mg/l	21	11	<0.002	0.013	0.004	0.003	0.004	0.010	0.003

SW-12 - Statistical Analysis
 Reporting Period - 5/2011 - 12/2016

Parameter	Units	No. Samples	No. Detects	Min.	Max.	Mean	25% PCTL	75% PCTL	95% PCTL	SD.
Flow	Cubic Ft Sec	--	--	8.84	24.2	16.5	12.7	20.4	23.4	10.9
pH - Field	s.u.	--	--	7.79	7.84	7.82	7.80	7.83	7.84	0.04
Specific Conductance	umhos/cm	--	--	75	97	86	81	92	96	16
Water Temperature	Deg C	--	--	10.8	14.1	12.5	11.6	13.3	13.9	2.3
Dissolved Oxygen	mg/l	--	--	8.69	9.23	8.96	8.83	9.10	9.20	0.38

SW-13 - Statistical Analysis
Reporting Period - 5/2011 - 12/2016

Parameter	Units	No. Samples	No. Detects	Min.	Max.	Mean	25% PCTL	75% PCTL	95% PCTL	SD.
Flow	Cubic Ft Sec	--	--	33.05	77.7	55.38	44.21	66.54	75.47	31.57
pH - Field	s.u.	--	--	7.74	8.66	8.20	7.97	8.43	8.61	0.65
Specific Conductance	umhos/cm	--	--	216	251	234	225	242	249	25
Water Temperature	Deg C	--	--	16.5	17.5	17.0	16.8	17.3	17.5	0.7
Dissolved Oxygen	mg/l	--	--	8.61	8.92	8.77	8.69	8.84	8.90	0.22

SW-14 - Statistical Analysis
Reporting Period - 5/2011 - 12/2016

Parameter	Units	No. Samples	No. Detects	Min.	Max.	Mean	25% PCTL	75% PCTL	95% PCTL	SD.
Flow	Cubic Ft Sec	--	--	0.29	11.75	3.44	0.83	4.54	10.17	3.81
pH - Field	s.u.	--	--	6.07	8.26	7.84	7.84	8.26	8.26	0.68
Specific Conductance	umhos/cm	--	--	284	425	370	332	414	422	50
Water Temperature	Deg C	--	--	0.36	13.7	8.6	7.0	12.4	13.6	4.4
Dissolved Oxygen	mg/l	--	--	7.59	12.74	10.08	9.37	10.39	12.10	1.35
Total Dissolved Solids	mg/l	8	8	175	243	222	214	236	241	23
Total Suspended Solids	mg/l	8	2	<4	15	10	7	12	14	8
Alkalinity as CaCO3	mg/l	8	8	160	220	204	195	220	220	23
Chloride	mg/l	8	8	1	2.5	2	2	2	2	0
Fluoride	mg/l	8	8	0.2	0.2	0	0	0	0	0
Sulfate	mg/l	8	8	7	16	9	7	9	15	3
Total Hardness	mg/l	7	7	159	232	209	205	225	231	--
Calcium (DIS)	mg/l	8	8	44	57	53	52	57	57	5
Magnesium (DIS)	mg/l	8	8	12	23	19	19	21	22	3
Potassium (DIS)	mg/l	8	8	1	1	1	1	1	1	0
Sodium (DIS)	mg/l	8	8	2	3	3	2	3	3	1
Nitrate + Nitrite as n	mg/l	8	8	0.01	0.27	0.07	0.02	0.08	0.21	0.09
Total Persulfate Nitrogen	mg/l	8	8	0.11	0.38	0.19	0.11	0.24	0.36	0.10
Phosphorus (TOT)	mg/l	8	6	<0.003	0.017	0.009	0.007	0.008	0.015	0.004
Aluminum (DIS)	mg/l	8	0	<0.009	--	--	--	--	--	--
Antimony (TRC)	mg/l	8	0	<0.0005	--	--	--	--	--	--
Arsenic (TRC)	mg/l	8	0	<0.001	--	--	--	--	--	--
Barium (TRC)	mg/l	8	8	0.091	0.122	0.111	0.110	0.116	0.120	0.010
Beryllium (TRC)	mg/l	8	0	<0.0008	--	--	--	--	--	--
Cadmium (TRC)	mg/l	8	2	<0.00003	0.00004	0.00004	0.00003	0.00004	0.00004	0.00001
Chromium (TRC)	mg/l	8	0	<0.01	--	--	--	--	--	--
Cobalt (TRC)	mg/l	8	0	<0.01	--	--	--	--	--	--
Copper (TRC)	mg/l	8	0	<0.002	--	--	--	--	--	--
Iron (TRC)	mg/l	8	8	0.02	0.28	0.11	0.06	0.13	0.23	0.08
Lead (TRC)	mg/l	8	1	<0.0003	0.0005	--	--	--	--	--
Manganese (TRC)	mg/l	8	1	<0.005	0.007	--	--	--	--	--
Mercury (TRC)	mg/l	8	0	<0.000005	--	--	--	--	--	--
Molybdenum (TRC)	mg/l	8	0	<0.002	--	--	--	--	--	--
Nickel (TRC)	mg/l	8	0	<0.001	--	--	--	--	--	--
Selenium (TRC)	mg/l	8	1	<0.0002	0.0003	--	--	--	--	--
Silver (TRC)	mg/l	8	0	<0.02	--	--	--	--	--	--
Strontium (TRC)	mg/l	8	8	0.0974	0.136	0.121	0.112	0.130	0.134	0.014
Thallium (TRC)	mg/l	8	0	<0.0002	--	--	--	--	--	--
Uranium (TRC)	mg/l	8	0	<0.008	--	--	--	--	--	--
Zinc (TRC)	mg/l	8	1	0.003	0.003	--	--	--	--	--

USGS-SC1 - Statistical Analysis
Reporting Period - 5/2011 - 12/2016

Parameter	Units	No. Samples	No. Detects	Min.	Max.	Mean	25% PCTL	75% PCTL	95% PCTL	SD.
Flow	Cubic Ft Sec	--	--	9.27	152	50	15	74	128	40
pH - Field	s.u.	--	--	6.82	8.67	8.03	7.83	8.29	8.52	0.42
Specific Conductance	umhos/cm	--	--	235	408	325	283	365	380	49
Water Temperature	Deg C	--	--	-0.98	12.6	4.5	0.4	8.3	10.9	4.0
Dissolved Oxygen	mg/l	--	--	7.12	16.55	10.94	9.96	11.67	13.34	1.71
Total Dissolved Solids	mg/l	36	36	134	230	192	186	204	214	22
Total Suspended Solids	mg/l	36	8	<4	38	16	10	18	33	11
Alkalinity as CaCO3	mg/l	36	36	120	220	178	178	190	200	23
Chloride	mg/l	36	36	1	5	2	1	2	3	1
Fluoride	mg/l	36	0	<0.1	--	--	--	--	--	--
Sulfate	mg/l	36	36	3	8	6	5	7	8	1
Total Hardness	mg/l	33	32	<7	214	178	167	191	210	--
Calcium (DIS)	mg/l	36	36	35	61	51	48	55	59	6
Magnesium (DIS)	mg/l	36	36	9	15	13	12	13	15	2
Potassium (DIS)	mg/l	36	36	2	3	1	1	1	1	0
Sodium (DIS)	mg/l	36	36	1	1	2	2	2	2	0
Nitrate + Nitrite as n	mg/l	36	23	<0.01	0.13	0.06	0.03	0.10	0.13	0.04
Nitrogen, Total (Calc)	mg/l	8	4	<0.5	5	3	2	4	5	1
Total Kjeldahl Nitrogen as n	mg/l	9	4	<0.5	5	3	2	4	5	1
Total Persulfate Nitrogen	mg/l	25	19	<0.04	0.16	0.10	0.07	0.15	0.15	0.04
Phosphorus (TOT)	mg/l	33	24	<0.003	0.04	0.01	0.01	0.01	0.02	0.01
Aluminum (DIS)	mg/l	36	9	<0.009	0.132	0.042	0.021	0.040	0.101	0.036
Antimony (TRC)	mg/l	35	0	<0.0005	--	--	--	--	--	--
Arsenic (TRC)	mg/l	35	1	<0.001	0.001	--	--	--	--	--
Barium (TRC)	mg/l	35	35	0.062	0.079	0.069	0.066	0.072	0.078	0.005
Beryllium (TRC)	mg/l	35	0	<0.0008	--	--	--	--	--	--
Cadmium (TRC)	mg/l	35	2	<0.00003	0.00009	0.00007	0.00005	0.00008	0.00009	0.00004
Chromium (TRC)	mg/l	35	0	<0.005	--	--	--	--	--	--
Cobalt (TRC)	mg/l	35	0	<0.005	--	--	--	--	--	--
Copper (TRC)	mg/l	35	1	<0.002	0.002	--	--	--	--	--
Iron (TRC)	mg/l	35	35	0.07	1.29	0.23	0.10	0.20	0.69	0.26
Lead (TRC)	mg/l	35	4	<0.0003	0.0008	0.0005	0.0003	0.0007	0.0008	0.0003
Manganese (TRC)	mg/l	35	35	0.006	0.03	0.01	0.01	0.01	0.02	0.01
Mercury (TRC)	mg/l	35	2	<0.000005	0.0000058	0.0000058	0.0000058	0.0000058	0.0000058	0.0000000
Molybdenum (TRC)	mg/l	35	0	<0.001	--	--	--	--	--	--
Nickel (TRC)	mg/l	35	4	<0.001	0.003	0.002	0.001	0.002	0.003	0.001
Selenium (TRC)	mg/l	35	0	<0.0002	--	--	--	--	--	--
Silver (TRC)	mg/l	35	0	<0.001	--	--	--	--	--	--
Strontium (TRC)	mg/l	35	35	0.123	0.163	0.142	0.136	0.146	0.159	0.009
Thallium (TRC)	mg/l	35	0	<0.0002	--	--	--	--	--	--
Uranium (TRC)	mg/l	35	2	0.0003	0.0004	0.0004	0.0003	0.0004	0.0004	0.0001
Zinc (TRC)	mg/l	35	9	<0.002	0.005	0.004	0.003	0.005	0.005	0.001

MW-1A - Statistical Analysis
Reporting Period - 5/2011 - 12/2016

Parameter	Units	No. Samples	No. Detects	Min.	Max.	Mean	25% PCTL	75% PCTL	95% PCTL	SD.
Depth To Water	ft	25	25	2.29	8.88	6.54	5.25	8.10	8.79	1.93
pH - Field	s.u.	22	22	6.62	7.66	7.22	7.07	7.41	7.48	0.25
Specific Conductance	umhos/cm	22	22	311	354	339	335	346	353	10
Water Temperature	Deg C	22	22	5.9	7.7	6.8	6.6	7.1	7.5	0.4
Dissolved Oxygen	mg/l	21	21	5	18	10	9	11	15	3
Total Dissolved Solids	mg/l	22	22	176	209	192	187	195	202	8
Total Suspended Solids	mg/l	15	14	10	1380	283	34	260	1049	428
Alkalinity as CaCO3	mg/l	22	22	170	190	175	170	180	180	6
Bicarbonate as HCO3	mg/l	6	6	210	230	217	210	220	228	8
Carbonate as CO3	mg/l	6	0	1	1	--	--	--	--	--
Chloride	mg/l	22	20	1	2	1	1	1	2	0
Fluoride	mg/l	22	22	0.2	0.3	0.2	0.2	0.2	0.2	0.0
Sulfate	mg/l	22	22	8	14	10	9	12	13	2
Total Hardness	mg/l	22	22	157	191	177	172	181	191	9
Calcium (DIS)	mg/l	22	22	38	45	42	41	43	45	2
Magnesium (DIS)	mg/l	22	22	15	21	18	17	18	19	1
Potassium (DIS)	mg/l	22	18	1	6	1	1	1	2	1
Sodium (DIS)	mg/l	22	22	2	11	4	2	5	10	3
Nitrate + Nitrite as n	mg/l	22	22	0.18	0.45	0.41	0.40	0.44	0.45	0.06
Nitrogen, Total (Calc)	mg/l	1	0	0.5	0.5	--	--	--	--	--
Total Kjeldahl Nitrogen as n	mg/l	1	0	0.5	0.5	--	--	--	--	--
Phosphorus (TOT)	mg/l	1	1	0.02	0.02	0.02	0.02	0.02	0.02	--
Aluminum (DIS)	mg/l	22	21	0.013	33.8	1.9	0.037	0.282	2.06	7.32
Antimony (DIS)	mg/l	22	0	0.0005	0.003	--	--	--	--	--
Arsenic (DIS)	mg/l	22	1	0.001	0.015	0.015	0.015	0.015	0.015	--
Barium (DIS)	mg/l	22	22	0.125	1.120	0.235	0.155	0.168	0.829	0.248
Beryllium (DIS)	mg/l	22	1	0.001	0.001	0.001	0.001	0.001	0.001	--
Cadmium (DIS)	mg/l	22	4	0.00003	0.00013	0.00008	0.00006	0.00011	0.00013	0.00004
Chromium (DIS)	mg/l	22	2	0.001	0.01	0.01	0.004	0.008	0.01	0.01
Cobalt (DIS)	mg/l	22	0	0.01	0.01	--	--	--	--	--
Copper (DIS)	mg/l	22	22	0.002	0.129	0.016	0.004	0.007	0.098	0.033
Iron (DIS)	mg/l	22	16	0.02	26.50	1.81	0.04	0.19	7.49	6.59
Lead (DIS)	mg/l	22	15	0.0003	0.157	0.02	0.0006	0.0022	0.09	0.04
Manganese (DIS)	mg/l	22	4	0.001	0.096	0.045	0.025	0.056	0.088	0.037
Mercury (DIS)	mg/l	22	3	0.000005	0.0001	0.00004	0.0000	0.0001	0.0001	0.0001
Molybdenum (DIS)	mg/l	22	0	0.001	0.005	--	--	--	--	--
Nickel (DIS)	mg/l	22	0	0.001000	0.010000	--	--	--	--	--
Selenium (DIS)	mg/l	22	5	0.0002	0.0010	0.0002	0.0002	0.0002	0.0003	0.0000
Silicon (DIS)	mg/l	1	1	15.5	15.5	15.5	15.5	15.5	15.5	--
Silver (DIS)	mg/l	22	0	0.0002	0.02	--	--	--	--	--
Strontium (DIS)	mg/l	22	22	0.0949	0.120	0.103	0.098	0.108	0.117	0.007
Thallium (DIS)	mg/l	22	22	0.0003	0.0048	0.0009	0.0005	0.0008	0.0019	0.0009
Uranium (DIS)	mg/l	22	7	0.0009	0.0080	0.0016	0.0012	0.0017	0.0028	0.0008
Zinc (DIS)	mg/l	22	7	0.002	0.040	0.015	0.003	0.025	0.037	0.015

MW-1B - Statistical Analysis
Reporting Period - 5/2011 - 12/2016

Parameter	Units	No. Samples	No. Detects	Min.	Max.	Mean	25% PCTL	75% PCTL	95% PCTL	SD.
Depth To Water	ft	25	23	20.93	24.11	22.60	21.96	23.28	23.51	0.82
pH - Field	s.u.	22	22	6.02	6.51	6.26	6.18	6.34	6.47	0.14
Specific Conductance	umhos/cm	22	22	556	661	600	586	616	626	24
Water Temperature	Deg C	22	22	6.5	8.8	7.4	7.0	7.9	8.2	0.6
Dissolved Oxygen	mg/l	21	21	0.1	2.8	0.6	0.2	0.7	1.2	0.6
Total Dissolved Solids	mg/l	25	25	336	435	404	401	425	429	26
Total Suspended Solids	mg/l	17	6	10	402	97	17	83	327	153
Alkalinity as CaCO3	mg/l	25	25	49	99	82	77	91	97	12
Bicarbonate as HCO3	mg/l	6	6	60	120	92	91	94	114	19
Carbonate as CO3	mg/l	6	0	1	1	--	--	--	--	--
Chloride	mg/l	25	21	1	3	1	1	1	2	1
Fluoride	mg/l	25	25	0.2	0.3	0.2	0.2	0.2	0.2	0.0
Sulfate	mg/l	25	25	200	247	225	220	233	239	11
Total Hardness	mg/l	25	25	234	291	267	263	275	287	14
Calcium (DIS)	mg/l	25	25	51	62	58	56	59	61	3
Magnesium (DIS)	mg/l	25	25	26	33	30	29	31	33	2
Potassium (DIS)	mg/l	25	25	3	3	3	3	3	3	0
Sodium (DIS)	mg/l	25	25	3	5	4	3	4	5	1
Nitrate + Nitrite as n	mg/l	25	11	0.01	0.60	0.11	0.04	0.08	0.38	0.17
Nitrogen, Total (Calc)	mg/l	1	0	0.5	0.5	--	--	--	--	--
Total Kjeldahl Nitrogen as n	mg/l	1	0	0.5	0.5	--	--	--	--	--
Phosphorus (TOT)	mg/l	1	1	0.03	0.03	0.03	0.03	0.03	0.03	--
Aluminum (DIS)	mg/l	25	6	0.009	0.039	0.018	0.012	0.017	0.034	0.010
Antimony (DIS)	mg/l	25	16	0.0005	0.003	0.0007	0.0007	0.0008	0.0009	0.0001
Arsenic (DIS)	mg/l	25	25	0.054	0.069	0.063	0.061	0.066	0.067	0.003
Arsenic +3 (TOT)	mg/l	1	1	0.060	0.060	0.060	0.060	0.060	0.060	--
Arsenic +5 (TOT)	mg/l	1	1	0.013	0.013	0.013	0.013	0.013	0.013	0.003
Barium (DIS)	mg/l	25	25	0.011	0.015	0.013	0.012	0.014	0.015	0.001
Beryllium (DIS)	mg/l	25	0	0.0008	0.001	--	--	--	--	--
Cadmium (DIS)	mg/l	25	0	0.00003	0.00008	--	--	--	--	--
Chromium (DIS)	mg/l	25	0	0.001	0.01	--	--	--	--	--
Cobalt (DIS)	mg/l	25	25	0.02	0.03	0.03	0.03	0.03	0.03	0.00
Copper (DIS)	mg/l	25	0	0.001	0.002	--	--	--	--	--
Iron (DIS)	mg/l	25	25	19.1	27.1	22.4	20.2	24.0	25.7	2.4
Lead (DIS)	mg/l	25	5	0.0003	0.0008	0.00046	0.0004	0.0004	0.0007	0.0002
Manganese (DIS)	mg/l	25	25	0.078	0.122	0.089	0.082	0.091	0.104	0.010
Mercury (DIS)	mg/l	25	2	0.000005	0.000010	0.000009	0.000009	0.000010	0.000010	0.000001
Molybdenum (DIS)	mg/l	25	0	0.001	0.005	--	--	--	--	--
Nickel (DIS)	mg/l	25	25	0.010	0.013	0.011	0.011	0.012	0.012	0.001
Selenium (DIS)	mg/l	25	0	0.0002	0.001	--	--	--	--	--
Silicon (DIS)	mg/l	1	1	13.4	13.4	13.4	13.4	13.4	13.4	--
Silver (DIS)	mg/l	25	0	0.0002	0.02	--	--	--	--	--
Strontium (DIS)	mg/l	25	25	1.4	1.72	1.6	1.6	1.6	1.7	0.1
Thallium (DIS)	mg/l	25	25	0.0104	0.0145	0.0125	0.0120	0.0131	0.0139	0.0009
Uranium (DIS)	mg/l	25	0	0.0002	0.008	--	--	--	--	--
Zinc (DIS)	mg/l	25	25	0.013	0.033	0.018	0.015	0.020	0.029	0.005

MW-2A - Statistical Analysis
Reporting Period - 5/2011 - 12/2016

Parameter	Units	No. Samples	No. Detects	Min.	Max.	Mean	25% PCTL	75% PCTL	95% PCTL	SD.
Depth To Water	ft	24	24	40.81	43.18	42.20	42.02	42.45	42.68	0.45
pH - Field	s.u.	20	20	7.07	7.52	7.28	7.20	7.36	7.52	0.14
Specific Conductance	umhos/cm	20	20	353	394	380	374	387	392	10
Water Temperature	Deg C	20	20	6.3	7.6	6.9	6.6	7.3	7.6	0.5
Total Dissolved Solids	mg/l	21	21	191	219	207	205	211	214	7
Total Suspended Solids	mg/l	14	3	10	14	13	12.5	13.5	13.9	1
Alkalinity as CaCO3	mg/l	21	21	180	210	192	190	200	200	7
Dissolved Oxygen	mg/l	20	20	4.30	12.96	7.28	6.59	7.65	9.66	1.82
Bicarbonate as HCO3	mg/l	6	6	230	250	237	230	240	248	8
Carbonate as CO3	mg/l	6	0	1	1	--	--	--	--	--
Chloride	mg/l	21	21	1	2	1	1	2	2	1
Fluoride	mg/l	21	21	0.3	0.4	0.4	0.3	0.4	0.4	0.1
Sulfate	mg/l	21	21	15	23	18	16	20	22	2
Total Hardness	mg/l	21	21	190	211	202	199	205	209	5
Calcium (DIS)	mg/l	21	21	40	45	43	42	44	44	1
Magnesium (DIS)	mg/l	21	21	22	24	23	23	23	24	1
Potassium (DIS)	mg/l	21	21	1	1	1	1	1	1	0
Sodium (DIS)	mg/l	21	21	2	3	3	2	3	3	0
Nitrate + Nitrite as n	mg/l	21	21	0.15	0.24	0.21	0.20	0.22	0.23	0.02
Nitrogen, Total (Calc)	mg/l	1	0	0.5	0.5	--	--	--	--	--
Total Kjeldahl Nitrogen as n	mg/l	1	0	0.5	0.5	--	--	--	--	--
Phosphorus (TOT)	mg/l	1	0	0.01	0.01	--	--	--	--	--
Aluminum (DIS)	mg/l	21	1	0.009	0.05	0.05	0.05	0.05	0.05	--
Antimony (DIS)	mg/l	21	0	0.0005	0.003	--	--	--	--	--
Arsenic (DIS)	mg/l	21	1	0.001	0.003	0.003	0.003	0.003	0.003	--
Barium (DIS)	mg/l	21	21	0.071	0.097	0.083	0.080	0.084	0.089	0.005
Beryllium (DIS)	mg/l	21	0	0.001	0.001	--	--	--	--	--
Cadmium (DIS)	mg/l	21	0	0.000	0.000	--	--	--	--	--
Chromium (DIS)	mg/l	21	0	0.001	0.01	--	--	--	--	--
Cobalt (DIS)	mg/l	21	0	0.01	0.01	--	--	--	--	--
Copper (DIS)	mg/l	21	1	0.001	0.002	0.001	0.001	0.001	0.001	--
Iron (DIS)	mg/l	21	1	0.02	0.18	0.18	0.18	0.18	0.18	--
Lead (DIS)	mg/l	21	1	0.0003	0.0009	0.0009	0.0009	0.0009	0.0009	--
Manganese (DIS)	mg/l	21	4	0.005	0.235	0.072	0.008	0.087	0.205	0.110
Mercury (DIS)	mg/l	21	2	0.000005	0.000015	0.000013	0.000011	0.000014	0.000015	0.000004
Molybdenum (DIS)	mg/l	21	0	0.002	0.005	--	--	--	--	--
Nickel (DIS)	mg/l	21	0	0.001000	0.01	--	--	--	--	--
Selenium (DIS)	mg/l	21	14	0.0002	0.0014	0.0008	0.0006	0.0010	0.0013	0.0003
Silicon (DIS)	mg/l	1	1	10.6	10.6	10.6	10.6	10.6	10.6	--
Silver (DIS)	mg/l	21	0	0.0002	0.02	--	--	--	--	--
Strontium (DIS)	mg/l	21	16	0.0836	0.10	0.09	0.09	0.09	0.09	0.00
Thallium (DIS)	mg/l	21	21	0.0002	0.0013	0.0004	0.0002	0.0004	0.0010	0.0003
Uranium (DIS)	mg/l	21	6	0.0004	0.008	0.0005	0.0004	0.0005	0.0006	0.0001
Zinc (DIS)	mg/l	21	0	0.00	0.01	--	--	--	--	--

MW-2B - Statistical Analysis
Reporting Period - 5/2011 - 12/2016

Parameter	Units	No. Samples	No. Detects	Min.	Max.	Mean	25% PCTL	75% PCTL	95% PCTL	SD.
Depth To Water	ft	24	24	40.77	43.14	42.03	41.81	42.29	42.57	0.47
pH - Field	s.u.	20	20	6.98	7.51	7.24	7.18	7.30	7.36	0.12
Specific Conductance	umhos/cm	20	20	425	525	461	441	470	514	28
Water Temperature	Deg C	20	20	3	7.6	6.7	6.5	7.4	7.5	1.0
Dissolved Oxygen	mg/l	20	20	0.2	1.33	1	0	1	1	0
Total Dissolved Solids	mg/l	21	21	234	292	261	250	270	287	15
Total Suspended Solids	mg/l	15	1	10	17	17	17	17	17	--
Alkalinity as CaCO3	mg/l	21	21	200	260	221	210	230	240	14
Bicarbonate as HCO3	mg/l	5	5	270	310	284	270	290	306	17
Carbonate as CO3	mg/l	5	0	1	1	--	--	--	--	--
Chloride	mg/l	21	19	1	2	1	1	2	2	0
Fluoride	mg/l	21	21	0.3	0.4	0.4	0.3	0.4	0.4	0.0
Sulfate	mg/l	21	21	35	51	41	37	44	47	4
Total Hardness	mg/l	21	21	236	280	256	245	265	276	12
Calcium (DIS)	mg/l	21	21	50	58	54	52	55	58	2
Magnesium (DIS)	mg/l	21	21	27	33	30	28	31	32	2
Potassium (DIS)	mg/l	21	21	1	2	2	2	2	2	0
Sodium (DIS)	mg/l	21	21	3	3	3	3	3	3	0
Nitrate + Nitrite as n	mg/l	21	0	0.01	0.5	--	--	--	--	--
Nitrogen, Total (Calc)	mg/l	1	0	0.5	0.5	--	--	--	--	--
Total Kjeldahl Nitrogen as n	mg/l	1	0	0.5	0.5	--	--	--	--	--
Phosphorus (TOT)	mg/l	1	0	0.01	0.01	--	--	--	--	--
Aluminum (DIS)	mg/l	21	1	0.009	0.03	0.01	0.013	0.013	0.01	--
Antimony (DIS)	mg/l	21	0	0.0005	0.003	--	--	--	--	--
Arsenic (DIS)	mg/l	21	20	0.003	0.018	0.004	0.003	0.004	0.007	0.003
Barium (DIS)	mg/l	21	21	0.028	0.048	0.041	0.040	0.042	0.045	0.00
Beryllium (DIS)	mg/l	21	0	0.0008	0.001	--	--	--	--	--
Cadmium (DIS)	mg/l	21	0	0.00003	0.00008	--	--	--	--	--
Chromium (DIS)	mg/l	21	0	0.001	0.01	--	--	--	--	--
Cobalt (DIS)	mg/l	21	0	0.01	0.01	--	--	--	--	--
Copper (DIS)	mg/l	21	0	0.001	0.002	--	--	--	--	--
Iron (DIS)	mg/l	21	21	0.02	1.08	0.14	0.04	0.13	0.25	0.23
Lead (DIS)	mg/l	21	0	0.0003	0.0005	--	--	--	--	--
Manganese (DIS)	mg/l	21	21	0.008	0.026	0.013	0.010	0.013	0.020	0.005
Mercury (DIS)	mg/l	21	1	0.000005	0.00001	0.00001	0.000009	0.000009	0.000009	--
Molybdenum (DIS)	mg/l	21	0	0.002	0.005	--	--	--	--	--
Nickel (DIS)	mg/l	21	0	0.001	0.01	--	--	--	--	--
Selenium (DIS)	mg/l	21	15	0.0002	0.0028	0.0011	0.0005	0.0017	0.0027	0.0009
Silicon (DIS)	mg/l	1	1	8.3	8.3	8.3	8.3	8.3	8.3	--
Silver (DIS)	mg/l	21	0	0.0002	0.02	--	--	--	--	--
Strontium (DIS)	mg/l	21	20	0.0903	0.106	0.099	0.095	0.100	0.104	0.004
Thallium (DIS)	mg/l	21	21	0.0024	0.004	0.0035	0.0034	0.0037	0.0040	0.0004
Uranium (DIS)	mg/l	21	5	0.002	0.008	0.002	0.002	0.002	0.002	0.000
Zinc (DIS)	mg/l	21	0	0.002	0.01	--	--	--	--	--

MW-3 - Statistical Analysis
Reporting Period - 5/2011 - 12/2016

Parameter	Units	No. Samples	No. Detects	Min.	Max.	Mean	25% PCTL	75% PCTL	95% PCTL	SD.
Depth To Water	ft	23	23	0.00	46.13	38.29	31.98	43.54	45.98	6.74
pH - Field	s.u.	19	19	6.77	7.31	7.05	6.98	7.11	7.27	0.12
Specific Conductance	umhos/cm	19	19	771	883	838	826	857	878	28
Water Temperature	Deg C	19	19	8.1	10.3	9.3	8.8	9.7	10.0	0.6
Total Dissolved Solids	mg/l	22	22	535	607	584	577	599	607	20
Total Suspended Solids	mg/l	15	0	10	10	--	--	--	--	--
Alkalinity as CaCO3	mg/l	22	22	210	230	218	220	220	220	5
Dissolved Oxygen	mg/l	19	19	0.07	2.09	0.40	0.15	0.36	1.49	0.50
Bicarbonate as HCO3	mg/l	7	7	260	290	271	270	270	284	9
Carbonate as CO3	mg/l	7	0	1	1	--	--	--	--	--
Chloride	mg/l	22	22	1	2	1.28	1	1.8	2.00	0.45
Fluoride	mg/l	22	22	0.6	0.8	0.7	0.7	0.8	0.8	0.1
Sulfate	mg/l	22	22	230	280	265	260	280	280	14
Total Hardness	mg/l	22	22	400	523	435	422	441	459	25
Calcium (DIS)	mg/l	22	22	76	124	85	81	84	99	10
Magnesium (DIS)	mg/l	22	22	51	58	54	53	56	58	2
Potassium (DIS)	mg/l	22	22	3	4	3	3	3	4	0
Sodium (DIS)	mg/l	22	22	14	17	16	15	16	17	1
Nitrate + Nitrite as n	mg/l	22	2	0.01	0.02	0.02	0.01	0.02	0.02	0.01
Nitrogen, Total (Calc)	mg/l	2	0	0.5	0.5	--	--	--	--	--
Total Kjeldahl Nitrogen as n	mg/l	2	0	0.5	0.5	--	--	--	--	--
Phosphorus (TOT)	mg/l	2	2	0.01	0.01	0.01	0.01	0.01	0.01	0.00
Aluminum (DIS)	mg/l	22	0	0.009	0.03	--	--	--	--	--
Antimony (DIS)	mg/l	22	0	0.0005	0.003	--	--	--	--	--
Arsenic (DIS)	mg/l	22	22	0.062	0.078	0.067	0.064	0.070	0.072	0.004
Arsenic +3 (TOT)	mg/l	1	1	0.064	0.064	0.064	0.064	0.064	0.064	--
Arsenic +5 (TOT)	mg/l	1	1	0.005	0.005	0.005	0.005	0.005	0.005	0.004
Barium (DIS)	mg/l	22	22	0.010	0.013	0.011	0.010	0.011	0.012	0.001
Beryllium (DIS)	mg/l	22	0	0.0008	0.001	--	--	--	--	--
Cadmium (DIS)	mg/l	22	0	0.00003	0.00008	--	--	--	--	--
Chromium (DIS)	mg/l	22	0	0.001	0.01	--	--	--	--	--
Cobalt (DIS)	mg/l	22	0	0.01	0.01	--	--	--	--	--
Copper (DIS)	mg/l	22	0	0.001	0.002	--	--	--	--	--
Iron (DIS)	mg/l	22	22	1.02	1.23	1.13	1.05	1.20	1.23	0.08
Lead (DIS)	mg/l	22	0	0.0003	0.0005	--	--	--	--	--
Manganese (DIS)	mg/l	22	22	0.018	0.035	0.025	0.020	0.027	0.035	0.005
Mercury (DIS)	mg/l	22	1	0.000005	0.00001	0.00001	0.00001	0.00001	0.00001	--
Molybdenum (DIS)	mg/l	22	1	0.001	0.005	0.001	0.001	0.001	0.001	--
Nickel (DIS)	mg/l	22	6	0.001	0.010	0.001	0.001	0.001	0.001	0.000
Selenium (DIS)	mg/l	22	0	0.0002	0.001	--	--	--	--	--
Silicon (DIS)	mg/l	1	1	8.3	8.3	8.3	8.3	8.3	8.3	--
Silver (DIS)	mg/l	22	0	0.0002	0.02	--	--	--	--	--
Strontium (DIS)	mg/l	22	22	13.0	16.2	14.5	14.0	15.0	15.8	0.8
Thallium (DIS)	mg/l	22	22	0.0003	0.0006	0.0004	0.0004	0.0004	0.0005	0.0001
Uranium (DIS)	mg/l	22	7	0.001	0.008	0.001	0.001	0.001	0.001	0.000
Zinc (DIS)	mg/l	22	1	0.002	0.010	0.008	0.008	0.008	0.008	--

MW-4A - Statistical Analysis
Reporting Period - 5/2011 - 12/2016

Parameter	Units	No. Samples	No. Detects	Min.	Max.	Mean	25% PCTL	75% PCTL	95% PCTL	SD.
Depth To Water	ft	30	30	3.36	6.02	4.95	4.77	5.49	5.79	0.70
pH - Field	s.u.	18	18	6.24	7.53	7.20	7.16	7.35	7.50	0.30
Specific Conductance	umhos/cm	18	18	481	551	508	490	522	537	20
Water Temperature	Deg C	18	18	4.3	8.5	6.4	4.7	7.6	8.2	1.5
Total Dissolved Solids	mg/l	19	19	270	302	288	280	296	301	10
Total Suspended Solids	mg/l	15	1	10	23	23	23	23	23	--
Alkalinity as CaCO3	mg/l	19	19	250	290	272	265	280	290	11
Dissolved Oxygen	mg/l	18	18	0.15	3.57	1.20	0.59	1.42	2.70	0.89
Bicarbonate as HCO3	mg/l	4	4	330	360	343	330	353	359	15
Carbonate as CO3	mg/l	4	0	1	1	--	--	--	--	--
Chloride	mg/l	19	19	2	4	2	2	3	3	1
Fluoride	mg/l	19	19	0.1	0.2	0.1	0.1	0.2	0.2	0.1
Sulfate	mg/l	19	19	8	21	14	12	17	20	4
Total Hardness	mg/l	18	18	253	292	278	275	284	290	10
Calcium (DIS)	mg/l	20	20	70	80	76	76	78	79	3
Magnesium (DIS)	mg/l	20	20	19	23	21	21	22	22	1
Potassium (DIS)	mg/l	20	20	1	2	1	1	2	2	1
Sodium (DIS)	mg/l	20	20	2	3	3	3	3	3	0
Nitrate + Nitrite as n	mg/l	19	2	0.01	0.02	0.02	0.01	0.02	0.02	0.01
Nitrogen, Total (Calc)	mg/l	1	0	0.5	0.5	--	--	--	--	--
Total Kjeldahl Nitrogen as n	mg/l	1	0	0.5	0.5	--	--	--	--	--
Phosphorus (TOT)	mg/l	1	0	0.01	0.01	--	--	--	--	--
Aluminum (DIS)	mg/l	20	2	0.009	0.087	0.060	0.046	0.073	0.084	0.039
Antimony (DIS)	mg/l	20	0	0.0005	0.003	--	--	--	--	--
Arsenic (DIS)	mg/l	20	0	0.001	0.003	--	--	--	--	--
Barium (DIS)	mg/l	20	20	0.172	0.203	0.185	0.183	0.189	0.192	0.006
Beryllium (DIS)	mg/l	20	0	0.0008	0.001	--	--	--	--	--
Cadmium (DIS)	mg/l	20	0	0.00003	0.00008	--	--	--	--	--
Chromium (DIS)	mg/l	20	0	0.001	0.01	--	--	--	--	--
Cobalt (DIS)	mg/l	20	0	0.01	0.01	--	--	--	--	--
Copper (DIS)	mg/l	20	0	0.001	0.002	--	--	--	--	--
Iron (DIS)	mg/l	20	16	0.02	0.16	0.04	0.03	0.04	0.09	0.03
Lead (DIS)	mg/l	20	1	0.0003	0.0005	0.0005	0.0005	0.0005	0.0005	--
Manganese (DIS)	mg/l	20	20	0.057	0.291	0.188	0.169	0.232	0.260	0.056
Mercury (DIS)	mg/l	20	1	0.000005	0.000010	0.000006	0.000006	0.000006	0.000006	--
Molybdenum (DIS)	mg/l	20	0	0.001	0.005	--	--	--	--	--
Nickel (DIS)	mg/l	20	0	0.00	0.01	--	--	--	--	--
Selenium (DIS)	mg/l	20	0	0.0002	0.001	--	--	--	--	--
Silicon (DIS)	mg/l	1	1	13.3	13.3	13.3	13.3	13.3	13.3	--
Silver (DIS)	mg/l	20	0	0.0002	0.02	--	--	--	--	--
Strontium (DIS)	mg/l	20	20	0.164	0.2	0.2	0.2	0.2	0.2	0.0
Thallium (DIS)	mg/l	20	0	0.0002	0.0002	--	--	--	--	--
Uranium (DIS)	mg/l	20	5	0.0004	0.008	0.0004	0.0004	0.0004	0.0004	0.0000
Zinc (DIS)	mg/l	20	1	0.002	0.010	0.010	0.010	0.010	0.010	--

MW-4B - Statistical Analysis
Reporting Period - 5/2011 - 12/2016

Parameter	Units	No. Samples	No. Detects	Min.	Max.	Mean	25% PCTL	75% PCTL	95% PCTL	SD.
Depth To Water	ft	30	30	3.02	7.26	4.54	4.30	5.02	5.44	0.81
pH - Field	s.u.	18	18	6.84	7.76	7.42	7.40	7.59	7.65	0.24
Specific Conductance	umhos/cm	18	18	419	510	459	446	472	505	25
Water Temperature	Deg C	18	18	5.3	6.5	6.1	5.9	6.3	6.5	0.3
Dissolved Oxygen	mg/l	18	18	0	3	1	0	1	2	1
Total Dissolved Solids	mg/l	19	19	231	275	253	246	260	272	12
Total Suspended Solids	mg/l	14	0	10	10	--	--	--	--	--
Alkalinity as CaCO3	mg/l	19	19	220	270	245	235	250	270	15
Bicarbonate as HCO3	mg/l	5	5	300	330	316	300	330	330	15
Carbonate as CO3	mg/l	5	0	1	1	--	--	--	--	--
Chloride	mg/l	19	19	1	2	2	1	2	2	0
Fluoride	mg/l	19	19	0.1	0.2	0.1	0.1	0.1	0.1	0.0
Sulfate	mg/l	19	19	11	26	15	13	17	22	4
Total Hardness	mg/l	19	19	167	265	244	237	256	265	22
Calcium (DIS)	mg/l	19	19	59	70	66	63	69	70	3
Magnesium (DIS)	mg/l	19	19	19	23	21	20	22	22	1
Potassium (DIS)	mg/l	19	19	1	2	1	1	1	2	0
Sodium (DIS)	mg/l	19	19	2	3	2	2	3	3	0
Nitrate + Nitrite as n	mg/l	19	13	0.01	0.06	0.04	0.03	0.05	0.06	0.02
Nitrogen, Total (Calc)	mg/l	1	0	0.5	0.5	--	--	--	--	--
Total Kjeldahl Nitrogen as n	mg/l	1	0	0.5	0.5	--	--	--	--	--
Phosphorus (TOT)	mg/l	1	0	0.01	0.01	--	--	--	--	--
Aluminum (DIS)	mg/l	19	1	0.009	0.03	0.03	0.027	0.027	0.03	--
Antimony (DIS)	mg/l	19	0	0.0005	0.003	--	--	--	--	--
Arsenic (DIS)	mg/l	19	0	0.001	0.003	--	--	--	--	--
Barium (DIS)	mg/l	19	19	0.117	0.147	0.128	0.122	0.131	0.146	0.008
Beryllium (DIS)	mg/l	19	0	0.001	0.001	--	--	--	--	--
Cadmium (DIS)	mg/l	19	0	0.000	0.000	--	--	--	--	--
Chromium (DIS)	mg/l	19	0	0.001	0.01	--	--	--	--	--
Cobalt (DIS)	mg/l	19	0	0.01	0.01	--	--	--	--	--
Copper (DIS)	mg/l	19	0	0.001	0.002	--	--	--	--	--
Iron (DIS)	mg/l	19	0	0.02	0.03	--	--	--	--	--
Lead (DIS)	mg/l	19	0	0.0003	0.0005	--	--	--	--	--
Manganese (DIS)	mg/l	19	3	0.00	0.01	0.00	0.00	0.01	0.01	0.00
Mercury (DIS)	mg/l	19	1	0.000005	0.000012	0.000012	0.000012	0.000012	0.000012	--
Molybdenum (DIS)	mg/l	19	0	0.001	0.005	--	--	--	--	--
Nickel (DIS)	mg/l	19	0	0.001000	0.010000	--	--	--	--	--
Selenium (DIS)	mg/l	19	0	0.000	0.020	--	--	--	--	--
Silicon (DIS)	mg/l	1	1	10.6	10.6	10.6	10.6	10.6	10.6	--
Silver (DIS)	mg/l	19	0	0.0002	0.02	--	--	--	--	--
Strontium (DIS)	mg/l	19	19	0.2	0.2	0.2	0.2	0.2	0.2	0.0
Thallium (DIS)	mg/l	19	2	0.0002	0.0002	0.0002	0.0002	0.0002	0.0002	0.0000
Uranium (DIS)	mg/l	19	5	0.0	0.0	0.0	0.0	0.0	0.0	0.0
Zinc (DIS)	mg/l	19	0	0.00	0.01	--	--	--	--	--

MW-6A - Statistical Analysis
Reporting Period - 5/2011 - 12/2016

Parameter	Units	No. Samples	No. Detects	Min.	Max.	Mean	25% PCTL	75% PCTL	95% PCTL	SD.
Depth To Water	ft	17	17	7.06	14.70	9.13	8.58	9.51	10.68	1.66
pH - Field	s.u.	12	12	6.61	7.64	7.35	7.19	7.50	7.63	0.30
Specific Conductance	umhos/cm	12	12	409	489	437	416	457	480	27
Water Temperature	Deg C	12	12	4.9	7.6	6.6	5.8	7.4	7.6	0.9
Total Dissolved Solids	mg/l	12	12	238	266	247	241	250	262	8
Total Suspended Solids	mg/l	10	7	10	193	99	50	143	191	68
Alkalinity as CaCO3	mg/l	12	12	210	250	234	228	243	250	13
Dissolved Oxygen	mg/l	12	12	3.07	8.09	5.77	5.13	6.79	7.67	1.47
Chloride	mg/l	12	10	1	1	1	1	1	1	0
Fluoride	mg/l	12	12	0.2	0.2	0.2	0.2	0.2	0.2	0.0
Sulfate	mg/l	12	11	1	17	13	11	15	17	2
Total Hardness	mg/l	12	12	224	264	243	231	254	264	14
Calcium (DIS)	mg/l	12	12	52	61	56	53	59	61	3
Magnesium (DIS)	mg/l	12	12	23	27	25	24	26	27	1
Potassium (DIS)	mg/l	12	1	1	1	1	1	1	1	--
Sodium (DIS)	mg/l	12	12	3	3	3	3	3	3	0
Nitrate + Nitrite as n	mg/l	12	12	0	0	0	0	0	0	0
Nitrogen, Total (Calc)	mg/l	1	0	1	1	--	--	--	--	--
Total Kjeldahl Nitrogen as n	mg/l	1	0	0.50	0.50	--	--	--	--	--
Phosphorus (TOT)	mg/l	1	1	0.06	0.06	0.06	0.06	0.06	0.06	--
Aluminum (DIS)	mg/l	12	3	0.009	1.55	0.52	0.01	0.78	1.40	0.89
Antimony (DIS)	mg/l	12	0	0.00	0.00	--	--	--	--	--
Arsenic (DIS)	mg/l	12	0	0.001	0.001	--	--	--	--	--
Arsenic +3 (TOT)	mg/l	1	0	0.005	0.005	--	--	--	--	--
Arsenic +5 (TOT)	mg/l	1	0	0.005	0.005	--	--	--	--	--
Barium (DIS)	mg/l	12	12	0.16	0.194	0.18	0.17	0.18	0.19	0.01
Beryllium (DIS)	mg/l	12	0	0.001	0.001	--	--	--	--	--
Cadmium (DIS)	mg/l	12	1	0.00003	0.00005	0.00005	0.00005	0.00005	0.00005	--
Chromium (DIS)	mg/l	12	0	0.01	0.01	--	--	--	--	--
Cobalt (DIS)	mg/l	12	0	0.01	0.01	--	--	--	--	--
Copper (DIS)	mg/l	12	0	0.002	0.002	--	--	--	--	--
Iron (DIS)	mg/l	12	1	0.02	0.7	0.7	0.7	0.7	0.7	--
Lead (DIS)	mg/l	12	1	0.0003	0.0009	0.0009	0.0009	0.0009	0.0009	--
Manganese (DIS)	mg/l	12	1	0.001	0.01	0.01	0.01	0.01	0.01	--
Mercury (DIS)	mg/l	12	0	0.000005	0.000005	--	--	--	--	--
Molybdenum (DIS)	mg/l	12	0	0.001	0.002	--	--	--	--	--
Nickel (DIS)	mg/l	12	1	0.001	0.001	0.001	0.001	0.001	0.001	--
Selenium (DIS)	mg/l	12	6	0.0002	0.0003	0.0003	0.0002	0.0003	0.0003	0.0001
Silicon (DIS)	mg/l	1	1	8.8	8.8	8.8	8.8	8.8	8.8	--
Silver (DIS)	mg/l	12	0	0.001	0.02	--	--	--	--	--
Strontium (DIS)	mg/l	12	12	0.149	0.175	0.162	0.158	0.165	0.174	0.008
Thallium (DIS)	mg/l	12	0	0.0002	0.0002	--	--	--	--	--
Uranium (DIS)	mg/l	12	1	0.0006	0.008	0.001	0.001	0.001	0.001	--
Zinc (DIS)	mg/l	12	1	0.002	0.005	0.005	0.005	0.005	0.005	--

MW-6B - Statistical Analysis
Reporting Period - 5/2011 - 12/2016

Parameter	Units	No. Samples	No. Detects	Min.	Max.	Mean	25% PCTL	75% PCTL	95% PCTL	SD.
Depth To Water	ft	16	16	10.24	17.93	12.31	11.66	12.75	14.16	1.72
pH - Field	s.u.	12	12	7.16	7.72	7.50	7.40	7.66	7.71	0.20
Specific Conductance	umhos/cm	12	12	422	508	456	444	467	500	26
Dissolved Oxygen	mg/l	12	12	1.8	4.6	3.4	2.7	4.0	4.5	0.9
Water Temperature	Deg C	12	12	5.4	6.7	6.3	6.3	6.5	6.7	0.3
Total Dissolved Solids	mg/l	12	12	236	272	255	251	262	269	10
Total Suspended Solids	mg/l	10	8	10	1260	205	14	96	897	432
Alkalinity as CaCO3	mg/l	12	12	220	240	232	230	240	240	7
Chloride	mg/l	12	10	1	2	1	1	1	2	0
Fluoride	mg/l	12	12	0.5	0.7	0.6	0.6	0.6	0.7	0.1
Sulfate	mg/l	12	12	16	26	21	18	23	26	3
Total Hardness	mg/l	12	12	203	230	218	211	225	230	9
Calcium (DIS)	mg/l	12	12	45	51	48	47	50	51	2
Magnesium (DIS)	mg/l	12	12	22	25	24	23	25	25	1
Potassium (DIS)	mg/l	12	12	1	2	1	1	1	1	0
Sodium (DIS)	mg/l	12	12	9	19	16	15	18	18	3
Nitrate + Nitrite as n	mg/l	12	12	0.06	0.14	0.10	0.07	0.11	0.13	0.03
Nitrogen, Total (Calc)	mg/l	1	0	0.5	0.5	--	--	--	--	--
Total Kjeldahl Nitrogen as n	mg/l	1	0	0.5	0.5	--	--	--	--	--
Phosphorus (TOT)	mg/l	1	1	0.04	0.04	0.04	0.04	0.04	0.04	--
Aluminum (DIS)	mg/l	12	6	0.009	0.275	0.060	0.010	0.036	0.217	0.106
Antimony (DIS)	mg/l	12	0	0.0005	0.0005	--	--	--	--	--
Arsenic (DIS)	mg/l	12	0	0.001	0.001	--	--	--	--	--
Arsenic +3 (TOT)	mg/l	1	0	0.005	0.005	--	--	--	--	--
Arsenic +5 (TOT)	mg/l	1	0	0.005	0.005	--	--	--	--	--
Barium (DIS)	mg/l	12	12	0.088	0.120	0.104	0.098	0.109	0.116	0.01
Beryllium (DIS)	mg/l	12	0	0.0008	0.0008	--	--	--	--	--
Cadmium (DIS)	mg/l	12	0	0.00003	0.00003	--	--	--	--	--
Chromium (DIS)	mg/l	12	0	0.01	0.01	--	--	--	--	--
Cobalt (DIS)	mg/l	12	0	0.01	0.01	--	--	--	--	--
Copper (DIS)	mg/l	12	0	0.002	0.002	--	--	--	--	--
Iron (DIS)	mg/l	12	2	0.02	0.15	0.09	0.06	0.12	0.14	0.08
Lead (DIS)	mg/l	12	1	0.0003	0.0003	0.0003	0.0003	0.0003	0.0003	--
Manganese (DIS)	mg/l	12	12	0.009	0.064	0.023	0.013	0.026	0.050	0.015
Mercury (DIS)	mg/l	12	0	0.000005	0.000005	--	--	--	--	--
Molybdenum (DIS)	mg/l	12	2	0.001	0.002	0.002	0.001	0.002	0.002	0.001
Nickel (DIS)	mg/l	12	0	0.001000	0.001000	--	--	--	--	--
Selenium (DIS)	mg/l	12	3	0.0002	0.0003	0.0002	0.0002	0.0003	0.0003	0.0001
Silicon (DIS)	mg/l	1	1	8.6	8.6	8.6	8.6	8.6	8.6	--
Silver (DIS)	mg/l	12	0	0.001	0.02	--	--	--	--	--
Strontium (DIS)	mg/l	12	12	0.181	0.254	0.223	0.209	0.240	0.249	0.022
Thallium (DIS)	mg/l	12	0	0.0002	0.0002	--	--	--	--	--
Uranium (DIS)	mg/l	12	1	0.0007	0.008	0.001	0.001	0.001	0.001	--
Zinc (DIS)	mg/l	12	0	0.002	0.002	--	--	--	--	--

MW-7 - Statistical Analysis
Reporting Period - 5/2011 - 12/2016

Parameter	Units	No. Samples	No. Detects	Min.	Max.	Mean	25% PCTL	75% PCTL	95% PCTL	SD.
Depth To Water	ft	17	17	30.92	37.90	32.44	31.84	32.64	34.23	1.56
pH - Field	s.u.	12	12	6.83	7.60	7.42	7.39	7.54	7.57	0.22
Specific Conductance	umhos/cm	12	12	490	582	537	518	554	574	28
Water Temperature	Deg C	12	12	6.3	8.3	7.3	6.9	7.9	8.1	0.6
Dissolved Oxygen	mg/l	12	12	0.14	2.09	0.96	0.49	1.35	1.94	0.61
Total Dissolved Solids	mg/l	12	12	304	348	322	309	332	345	15
Total Suspended Solids	mg/l	10	9	10	1440	374	111	418	1084	432
Alkalinity as CaCO3	mg/l	12	12	230	280	242	230	240	275	16
Chloride	mg/l	12	12	3	5	4	3	4	5	1
Fluoride	mg/l	12	12	0.3	0.7	0.4	0.3	0.3	0.5	0.1
Sulfate	mg/l	12	12	54	84	66	61	71	81	10
Total Hardness	mg/l	12	12	279	322	300	289	310	318	14
Calcium (DIS)	mg/l	12	12	54	63	58	58	60	62	3
Magnesium (DIS)	mg/l	12	12	35	40	38	36	39	39	2
Potassium (DIS)	mg/l	12	12	1	3	1	1	1	2	1
Sodium (DIS)	mg/l	12	12	2	4	3	3	3	3	1
Nitrate + Nitrite as n	mg/l	12	2	0.01	0.05	0.03	0.03	0.03	0.03	0.00
Nitrogen, Total (Calc)	mg/l	1	0	0.5	0.5	--	--	--	--	--
Total Kjeldahl Nitrogen as n	mg/l	1	0	0.5	0.5	--	--	--	--	--
Phosphorus (TOT)	mg/l	1	1	0.04	0.04	0.04	0.04	0.04	0.04	--
Aluminum (DIS)	mg/l	12	10	0.009	0.097	0.039	0.014	0.068	0.088	0.033
Antimony (DIS)	mg/l	12	2	0.0005	0.0094	0.0054	0.0034	0.0074	0.0090	0.0057
Arsenic (DIS)	mg/l	12	12	0.002	0.003	0.002	0.002	0.002	0.003	0.000
Arsenic +3 (TOT)	mg/l	1	0	0.005	0.005	--	--	--	--	--
Arsenic +5 (TOT)	mg/l	1	0	0.005	0.005	--	--	--	--	--
Barium (DIS)	mg/l	12	12	0.042	0.066	0.049	0.043	0.051	0.065	0.008
Beryllium (DIS)	mg/l	12	0	0.0008	0.0008	--	--	--	--	--
Cadmium (DIS)	mg/l	12	0	0.00003	0.00003	--	--	--	--	--
Chromium (DIS)	mg/l	12	0	0.01	0.01	--	--	--	--	--
Cobalt (DIS)	mg/l	12	0	0.01	0.01	--	--	--	--	--
Copper (DIS)	mg/l	12	0	0.002	0.002	--	--	--	--	--
Iron (DIS)	mg/l	12	11	0.02	0.15	0.06	0.05	0.07	0.14	0.04
Lead (DIS)	mg/l	12	7	0.0003	0.0012	0.0006	0.0004	0.00085	0.0011	0.0003
Manganese (DIS)	mg/l	12	12	0.021	0.369	0.090	0.044	0.100	0.230	0.093
Mercury (DIS)	mg/l	12	1	0.000005	0.000005	0.000005	0.000005	0.000005	0.000005	--
Molybdenum (DIS)	mg/l	12	10	0.002	0.012	0.004	0.002	0.003	0.009	0.003
Nickel (DIS)	mg/l	12	1	0.001	0.001	0.001	0.001	0.001	0.001	--
Selenium (DIS)	mg/l	12	1	0.0002	0.0005	0.0005	0.0005	0.0005	0.0005	--
Silicon (DIS)	mg/l	1	1	8.2	8.2	8.2	8.2	8.2	8.2	--
Silver (DIS)	mg/l	12	0	0.001	0.02	--	--	--	--	--
Strontium (DIS)	mg/l	12	12	0.158	0.205	0.170	0.162	0.169	0.198	0.014
Thallium (DIS)	mg/l	12	0	0.0002	0.0002	--	--	--	--	--
Uranium (DIS)	mg/l	12	1	0.0031	0.008	0.003	0.003	0.003	0.003	--
Zinc (DIS)	mg/l	12	0	0.002	0.002	--	--	--	--	--

MW-8 - Statistical Analysis
Reporting Period - 5/2011 - 12/2016

Parameter	Units	No. Samples	No. Detects	Min.	Max.	Mean	25% PCTL	75% PCTL	95% PCTL	SD.
Depth To Water	ft	17	17	27.55	36.92	30.93	30.26	31.38	33.43	2.02
pH - Field	s.u.	12	12	7.46	8.04	7.81	7.63	7.96	8.03	0.20
Specific Conductance	umhos/cm	12	12	280	330	308	301	314	329	15
Water Temperature	Deg C	12	12	6.0	7.3	6.8	6.7	7.1	7.2	0.4
Dissolved Oxygen	mg/l	12	12	0.05	1.30	0.39	0.13	0.48	1.06	0.37
Total Dissolved Solids	mg/l	12	12	153	171	164	163	166	170	5
Total Suspended Solids	mg/l	10	4	10	65	30	16	34	59	24
Alkalinity as CaCO3	mg/l	12	12	150	170	158	150	160	170	8
Chloride	mg/l	12	0	1	1	--	--	--	--	--
Fluoride	mg/l	12	12	0.2	0.3	0.25	0.2	0.3	0.3	0.1
Sulfate	mg/l	12	12	11	16	14	12	15	16	2
Total Hardness	mg/l	12	12	153	173	163	161	166	170	6
Calcium (DIS)	mg/l	12	12	25	29	27	27	27	28	1
Magnesium (DIS)	mg/l	12	12	22	25	23	23	24	24	1
Potassium (DIS)	mg/l	12	2	1	1	1	1	1	1	0
Sodium (DIS)	mg/l	12	12	3	6	3	3	3	5	1
Nitrate + Nitrite as n	mg/l	12	1	0.01	0.01	0.01	0.01	0.01	0.01	--
Nitrogen, Total (Calc)	mg/l	1	0	0.5	0.5	--	--	--	--	--
Total Kjeldahl Nitrogen as n	mg/l	1	0	0.5	0.5	--	--	--	--	--
Phosphorus (TOT)	mg/l	1	1	0.01	0.01	0.01	0.01	0.01	0.01	--
Aluminum (DIS)	mg/l	12	3	0.009	0.036	0.021	0.014	0.026	0.034	0.013
Antimony (DIS)	mg/l	12	6	0.0005	0.0179	0.0039	0.0006	0.0023	0.0141	0.0069
Arsenic (DIS)	mg/l	12	12	0.002	0.004	0.003	0.002	0.003	0.003	0.001
Arsenic +3 (TOT)	ug/l	1	0	0.005	0.005	--	--	--	--	--
Arsenic +5 (TOT)	mg/l	1	0	0.005	0.005	--	--	--	--	--
Barium (DIS)	mg/l	12	12	0.069	0.078	0.074	0.073	0.075	0.078	0.003
Beryllium (DIS)	mg/l	12	0	0.0008	0.0008	--	--	--	--	--
Cadmium (DIS)	mg/l	12	0	0.00003	0.00003	--	--	--	--	--
Chromium (DIS)	mg/l	12	0	0.01	0.01	--	--	--	--	--
Cobalt (DIS)	mg/l	12	0	0.01	0.01	--	--	--	--	--
Copper (DIS)	mg/l	12	0	0.002	0.002	--	--	--	--	--
Iron (DIS)	mg/l	12	12	0.02	0.1	0.1	0.1	0.1	0.1	0.0
Lead (DIS)	mg/l	12	0	0.0003	0.0003	--	--	--	--	--
Manganese (DIS)	mg/l	12	12	0.02	0.26	0.07	0.03	0.07	0.17	0.06
Mercury (DIS)	mg/l	12	0	0.000005	0.000005	--	--	--	--	--
Molybdenum (DIS)	mg/l	12	9	0.002	0.015	0.004	0.003	0.004	0.011	0.004
Nickel (DIS)	mg/l	12	1	0.001	0.001	0.001	0.001	0.001	0.001	--
Selenium (DIS)	mg/l	12	2	0.0002	0.0328	0.0173	0.0095	0.0250	0.0312	0.0220
Silicon (DIS)	mg/l	1	1	8.7	8.7	8.7	8.7	8.7	8.7	--
Silver (DIS)	mg/l	12	0	0.001	0.02	--	--	--	--	--
Strontium (DIS)	mg/l	12	12	0.082	0.0984	0.088	0.086	0.089	0.094	0.004
Thallium (DIS)	mg/l	12	0	0.0002	0.0002	--	--	--	--	--
Uranium (DIS)	mg/l	12	1	0.0	0.0	0.0	0.0	0.0	0.0	--
Zinc (DIS)	mg/l	12	1	0.002	0.002	0.002	0.002	0.002	0.002	--

MW-9 - Statistical Analysis
Reporting Period - 5/2011 - 12/2016

Parameter	Units	No. Samples	No. Detects	Min.	Max.	Mean	25% PCTL	75% PCTL	95% PCTL	SD.
Depth To Water	ft	13	13	49.14	51.90	50.65	49.95	51.31	51.86	0.93
pH - Field	s.u.	9	9	6.72	7.15	6.99	6.92	7.07	7.13	0.13
Specific Conductance	umhos/cm	9	9	470	793	739	756	789	791	104
Water Temperature	Deg C	9	9	6.8	9.1	8.1	7.5	8.7	9.0	0.7
Dissolved Oxygen	mg/l	9	9	0	1	1	0	1	1	0
Total Dissolved Solids	mg/l	9	9	501	548	526	520	533	542	13
Total Suspended Solids	mg/l	8	1	10	51	51	51	51	51	--
Alkalinity as CaCO3	mg/l	9	9	240	250	242	240	240	250	4
Chloride	mg/l	9	9	1	2	1	1	1	2	0
Fluoride	mg/l	9	9	0.5	0.6	0.6	0.6	0.6	0.6	0.0
Sulfate	mg/l	9	9	198	216	207	203	213	215	6
Total Hardness	mg/l	9	9	403	454	433	427	443	450	14
Calcium (DIS)	mg/l	9	9	83	91	88	88	90	91	2
Magnesium (DIS)	mg/l	9	9	48	55	52	51	53	54	2
Potassium (DIS)	mg/l	9	9	4	5	4	4	4	5	0
Sodium (DIS)	mg/l	9	9	5	6	5	5	5	6	0
Nitrate + Nitrite as n	mg/l	9	1	0.01	0.02	0.02	0.02	0.02	0.02	--
Aluminum (DIS)	mg/l	9	3	0.009	0.042	0.027	0.019	0.032	0.040	0.014
Antimony (DIS)	mg/l	9	0	0.00	0.00	--	--	--	--	--
Arsenic (DIS)	mg/l	9	9	0.012	0.014	0.013	0.012	0.014	0.014	0.001
Barium (DIS)	mg/l	9	9	0.012	0.021	0.01	0.014	0.015	0.019	0.003
Beryllium (DIS)	mg/l	9	0	0.0008	0.0008	--	--	--	--	--
Cadmium (DIS)	mg/l	9	0	0.00003	0.00003	--	--	--	--	--
Chromium (DIS)	mg/l	9	0	0.01	0.01	--	--	--	--	--
Cobalt (DIS)	mg/l	9	0	0.010	0.010	--	--	--	--	--
Copper (DIS)	mg/l	9	0	0.002	0.002	--	--	--	--	--
Iron (DIS)	mg/l	9	9	0.78	0.87	0.82	0.81	0.85	0.86	--
Lead (DIS)	mg/l	9	6	0.0003	0.0034	0.0016	0.0007	0.0024	0.0033	0.0012
Manganese (DIS)	mg/l	9	9	0.088	0.129	0.102	0.096	0.105	0.121	0.012
Mercury (DIS)	mg/l	9	0	0.000005	0.000005	--	--	--	--	--
Molybdenum (DIS)	mg/l	9	0	0.002	0.002	--	--	--	--	--
Nickel (DIS)	mg/l	9	8	0.001	0.001	0.001	0.001	0.001	0.001	0
Selenium (DIS)	mg/l	9	0	0.0002	0.0002	--	--	--	--	--
Silicon (DIS)	mg/l	1	1	7.4	7.4	7.4	7.4	7.4	7.4	--
Silver (DIS)	mg/l	9	0	0.02	0.02	--	--	--	--	--
Strontium (DIS)	mg/l	9	9	1.13	1.40	1.24	1.19	1.29	1.37	0.09
Thallium (DIS)	mg/l	9	9	0.0034	0.0041	0.0038	0.0037	0.0038	0.0041	0.0002
Uranium (DIS)	mg/l	9	0	0.008	0.008	--	--	--	--	--
Zinc (DIS)	mg/l	9	4	0.002	0.003	0.003	0.003	0.003	0.003	0.001

MW-10 - Statistical Analysis
Reporting Period - 5/2011 - 12/2016

Parameter	Units	No. Samples	No. Detects	Min.	Max.	Mean	25% PCTL	75% PCTL	95% PCTL	SD.
Depth To Water	ft	4	4	64.97	79.10	74.12	72.37	77.96	78.87	6.35
pH - Field	s.u.	4	4	7.56	7.87	7.72	7.60	7.86	7.87	0.16
Specific Conductance	umhos/cm	4	4	319	364	337	321	348	361	21
Water Temperature	Deg C	4	4	5.9	8.6	7.4	7.0	7.8	8.4	1.1
Dissolved Oxygen	mg/l	4	4	6.24	9.74	7.30	6.34	7.56	9.30	1.65
Total Dissolved Solids	mg/l	4	4	174	244	204	192	211	237	29
Total Suspended Solids	mg/l	4	4	48	466	189	60	250	423	194
Alkalinity as CaCO3	mg/l	4	4	170	180	175	170	180	180	6
Chloride	mg/l	4	3	1	4	3	3	4	4	1
Fluoride	mg/l	4	4	0.3	0.5	0.4	0.4	0.4	0.5	0.1
Sulfate	mg/l	4	4	4.7	8.0	6.7	5.7	8.0	8.0	1.6
Total Hardness	mg/l	4	4	157	185	167	158	172	182	13
Calcium (DIS)	mg/l	4	4	35	46	39	37	41	45	5
Magnesium (DIS)	mg/l	4	4	16	17	17	17	17	17	1
Potassium (DIS)	mg/l	4	4	3	7	4	3	5	7	2
Sodium (DIS)	mg/l	4	4	7	11	9	8	11	11	2
Nitrate + Nitrite as n	mg/l	4	4	0.46	0.53	0.51	0.49	0.53	0.53	0.03
Aluminum (DIS)	mg/l	4	4	0.031	3.660	0.973	0.075	0.998	3.128	1.792
Antimony (DIS)	mg/l	4	0	0.0005	0.0005	--	--	--	--	--
Arsenic (DIS)	mg/l	4	0	0.001	0.001	--	--	--	--	--
Barium (DIS)	mg/l	4	4	0.135	0.211	0.161	0.144	0.167	0.202	0.034
Beryllium (DIS)	mg/l	4	0	0.0008	0.0008	--	--	--	--	--
Cadmium (DIS)	mg/l	4	1	0.00003	0.00008	0.0001	0.00008	0.00008	0.0001	--
Chromium (DIS)	mg/l	4	1	0.01	0.01	0.01	0.01	0.01	0.01	--
Cobalt (DIS)	mg/l	4	0	0.01	0.01	--	--	--	--	--
Copper (DIS)	mg/l	4	1	0.002	0.010	0.010	0.010	0.010	0.010	--
Iron (DIS)	mg/l	4	4	0.03	3.58	0.94	0.05	0.98	3.06	--
Lead (DIS)	mg/l	4	1	0.0003	0.0021	0.0021	0.0021	0.0021	0.0021	--
Manganese (DIS)	mg/l	4	4	0.005	0.168	0.061	0.014	0.083	0.151	0.074
Mercury (DIS)	mg/l	4	1	0.000005	0.0000066	0.00001	0.0000066	0.0000066	0.00001	--
Molybdenum (DIS)	mg/l	4	4	0.007	0.012	0.010	0.008	0.011	0.012	0.002
Nickel (DIS)	mg/l	4	4	0.001	0.009	0.004	0.002	0.004	0.008	0.004
Selenium (DIS)	mg/l	4	2	0.0002	0.0002	0.0002	0.0002	0.0002	0.0002	0.0000
Silver (DIS)	mg/l	4	0	0.02	0.02	--	--	--	--	--
Strontium (DIS)	mg/l	4	4	0.796	1.35	1.07	0.97	1.17	1.31	0.23
Thallium (DIS)	mg/l	4	0	0.0002	0.0002	--	--	--	--	--
Uranium (DIS)	mg/l	4	4	0.008	0.016	0.014	0.013	0.016	0.016	0.004
Zinc (DIS)	mg/l	4	2	0.002	0.015	0.009	0.006	0.012	0.014	0.008

MW-11 - Statistical Analysis
Reporting Period - 5/2011 - 12/2016

Parameter	Units	No. Samples	No. Detects	Min.	Max.	Mean	25% PCTL	75% PCTL	95% PCTL	SD.
Depth To Water	ft	4	4	25.74	34.56	32.04	31.49	34.49	34.55	4.76
pH - Field	s.u.	4	4	7.40	7.71	7.54	7.42	7.64	7.70	0.16
Specific Conductance	umhos/cm	4	4	309	393	343	324	354	385	16
Water Temperature	Deg C	4	4	6.7	7.6	7.2	6.9	7.6	7.6	0.5
Dissolved Oxygen	mg/l	4	4	5.66	7.99	7.13	6.63	7.92	7.98	0.58
Total Dissolved Solids	mg/l	5	5	174	238	194.8	186	188	228	7
Total Suspended Solids	mg/l	5	4	10	436	132	16	157	380	204
Alkalinity as CaCO3	mg/l	5	5	160	180	170	160	180	180	12
Chloride	mg/l	5	1	1	2	2	2	2	2	--
Fluoride	mg/l	5	5	0.1	0.1	0.1	0.1	0.1	0.1	0
Sulfate	mg/l	5	5	7.7	31.0	14.5	8.0	13.0	27.4	3.0
Total Hardness	mg/l	5	5	148	163	156	153	161	163	5
Calcium (DIS)	mg/l	5	5	40	43	42	41	43	43	1
Magnesium (DIS)	mg/l	5	5	11	15	12	11	14	15	2
Potassium (DIS)	mg/l	5	5	2	2	2	2	2	2	0
Sodium (DIS)	mg/l	5	5	7	21	11	9	10	19	1
Nitrate + Nitrite as n	mg/l	5	5	0.37	0.39	0.38	0.37	0.39	0.39	0.01
Aluminum (DIS)	mg/l	5	5	0.024	0.658	0.212	0.028	0.263	0.579	0.307
Antimony (DIS)	mg/l	5	0	0.0005	0.0005	--	--	--	--	--
Arsenic (DIS)	mg/l	5	0	0.001	0.001	--	--	--	--	--
Barium (DIS)	mg/l	5	5	0.126	0.148	0.14	0.144	0.145	0.1474	0.009
Beryllium (DIS)	mg/l	5	0	0.0008	0.0008	--	--	--	--	--
Cadmium (DIS)	mg/l	5	0	0.00003	0.00003	--	--	--	--	--
Chromium (DIS)	mg/l	5	0	0.01	0.01	--	--	--	--	--
Cobalt (DIS)	mg/l	5	0	0.01	0.01	--	--	--	--	--
Copper (DIS)	mg/l	5	0	0.002	0.002	--	--	--	--	--
Iron (DIS)	mg/l	5	3	0.02	0.22	0.11	0.06	0.15	0.21	--
Lead (DIS)	mg/l	5	1	0.0003	0.0004	0.0004	0.0004	0.0004	0.0004	--
Manganese (DIS)	mg/l	5	2	0.005	0.020	0.013	0.009	0.016	0.019	--
Mercury (DIS)	mg/l	5	0	0.000005	0.000005	--	--	--	--	--
Molybdenum (DIS)	mg/l	5	0	0.002	0.002	--	--	--	--	--
Nickel (DIS)	mg/l	5	2	0.00100	0.00200	0.00150	0.00125	0.00175	0.00195	0.00071
Selenium (DIS)	mg/l	5	0	0.0002	0.0002	--	--	--	--	--
Silver (DIS)	mg/l	5	0	0.02	0.02	--	--	--	--	--
Strontium (DIS)	mg/l	5	5	0.261	1.370	0.680	0.284	1.200	1.336	0.582
Thallium (DIS)	mg/l	5	0	0.0002	0.0002	--	--	--	--	--
Uranium (DIS)	mg/l	5	0	0.008	0.008	--	--	--	--	--
Zinc (DIS)	mg/l	5	0	0.002	0.002	--	--	--	--	--

MW-12 - Statistical Analysis
Reporting Period - 5/2011 - 12/2016

Parameter	Units	No. Samples	No. Detects	Min.	Max.	Mean	25% PCTL	75% PCTL	95% PCTL	SD.
Depth To Water	ft	4	4	21.96	30.20	26.88	25.86	28.69	29.90	3.51
pH - Field	s.u.	4	4	7.25	7.55	7.41	7.32	7.51	7.54	0.14
Specific Conductance	umhos/cm	4	4	399	437	416	407	424	434	16
Water Temperature	Deg C	4	4	5.4	7.0	6.2	5.9	6.4	6.9	0.7
Dissolved Oxygen	mg/l	4	4	6.27	9.78	8.34	7.21	9.78	9.78	1.74
Total Dissolved Solids	mg/l	5	5	217	228	222	219	227	228	5
Total Suspended Solids	mg/l	5	1	10	26	26	26	26	26	--
Alkalinity as CaCO3	mg/l	5	5	210	220	212	210	210	218	4
Chloride	mg/l	5	0	1	1	--	--	--	--	--
Fluoride	mg/l	5	5	0.1	0.1	0.1	0.1	0.1	0.1	0
Sulfate	mg/l	5	5	10	13	12	12	13	13	1
Total Hardness	mg/l	5	5	223	235	226	223	227	233	5
Calcium (DIS)	mg/l	5	5	58	61	59	58	58	60	1
Magnesium (DIS)	mg/l	5	5	19	20	19	19	20	20	1
Potassium (DIS)	mg/l	5	0	1	1	--	--	--	--	--
Sodium (DIS)	mg/l	5	5	2	2	2	2	2	2	0
Nitrate + Nitrite as n	mg/l	5	5	0.15	0.16	0.15	0.15	0.15	0.16	0.00
Aluminum (DIS)	mg/l	5	0	0.009	0.009	--	--	--	--	--
Antimony (DIS)	mg/l	5	0	0.0005	0.0005	--	--	--	--	--
Arsenic (DIS)	mg/l	5	0	0.001	0.001	--	--	--	--	--
Barium (DIS)	mg/l	5	5	0.048	0.054	0.05	0.05	0.054	0.054	0.003
Beryllium (DIS)	mg/l	5	0	0.0008	0.0008	--	--	--	--	--
Cadmium (DIS)	mg/l	5	0	0.00003	0.00003	--	--	--	--	--
Chromium (DIS)	mg/l	5	0	0.01	0.01	--	--	--	--	--
Cobalt (DIS)	mg/l	5	0	0.010	0.010	--	--	--	--	--
Copper (DIS)	mg/l	5	0	0.002	0.002	--	--	--	--	--
Iron (DIS)	mg/l	5	0	0.02	0.02	--	--	--	--	--
Lead (DIS)	mg/l	5	0	0.0003	0.0003	--	--	--	--	--
Manganese (DIS)	mg/l	5	0	0.005	0.005	--	--	--	--	--
Mercury (DIS)	mg/l	5	0	0.000005	0.000005	--	--	--	--	--
Molybdenum (DIS)	mg/l	5	0	0.002	0.002	--	--	--	--	--
Nickel (DIS)	mg/l	5	0	0.001	0.001	--	--	--	--	--
Selenium (DIS)	mg/l	5	1	0.0002	0.0002	0.0002	0.0002	0.0002	0.0002	--
Silver (DIS)	mg/l	5	0	0.02	0.02	--	--	--	--	--
Strontium (DIS)	mg/l	5	5	0.14	0.144	0.14	0.14	0.14	0.14	0.00
Thallium (DIS)	mg/l	5	0	0.0002	0.0002	--	--	--	--	--
Uranium (DIS)	mg/l	5	0	0.008	0.008	--	--	--	--	--
Zinc (DIS)	mg/l	5	0	0.002	0.002	--	--	--	--	--

MW-13 - Statistical Analysis
Reporting Period - 5/2011 - 12/2016

Parameter	Units	No. Samples	No. Detects	Min.	Max.	Mean	25% PCTL	75% PCTL	95% PCTL	SD.
Depth To Water	ft	4	4	17.92	22.28	20.75	20.35	21.80	22.18	1.94
pH - Field	s.u.	4	4	6.74	7.52	7.29	7.22	7.52	7.52	0.37
Specific Conductance	umhos/cm	4	4	392	451	425	416	438	448	25
Water Temperature	Deg C	4	4	5.8	6.3	6.0	5.9	6.1	6.3	0.2
Dissolved Oxygen	mg/l	4	4	6.32	8.73	7.63	6.95	8.40	8.66	1.09
Total Dissolved Solids	mg/l	5	5	226	248	236	227	240	246	9
Total Suspended Solids	mg/l	5	3	10	319	123	25	173	290	170
Alkalinity as CaCO3	mg/l	5	5	210	220	216	210	220	220	5
Chloride	mg/l	5	1	1	1	1	1	1	1	--
Fluoride	mg/l	5	5	0.1	0.1	0.1	0.1	0.1	0.1	0.0
Sulfate	mg/l	5	5	14	18	16	15	16	18	1
Total Hardness	mg/l	4	4	230	244	237	232	240	243	6
Calcium (DIS)	mg/l	5	5	59	63	61	59	63	63	2
Magnesium (DIS)	mg/l	5	5	20	21	21	21	21	21	0
Potassium (DIS)	mg/l	5	0	1	1	--	--	--	--	--
Sodium (DIS)	mg/l	5	5	1	2	1	1	2	2	1
Nitrate + Nitrite as n	mg/l	5	5	0.18	0.22	0.19	0.18	0.19	0.21	0.02
Aluminum (DIS)	mg/l	5	4	0.009	0.036	0.017	0.010	0.020	0.033	0.013
Antimony (DIS)	mg/l	5	0	0.0005	0.0005	--	--	--	--	--
Arsenic (DIS)	mg/l	5	0	0.001	0.001	--	--	--	--	--
Barium (DIS)	mg/l	5	5	0.054	0.056	0.055	0.055	0.055	0.056	0.001
Beryllium (DIS)	mg/l	5	0	0.0008	0.0008	--	--	--	--	--
Cadmium (DIS)	mg/l	5	0	0.00003	0.00003	--	--	--	--	--
Chromium (DIS)	mg/l	5	0	0.01	0.01	--	--	--	--	--
Cobalt (DIS)	mg/l	5	0	0.01	0.01	--	--	--	--	--
Copper (DIS)	mg/l	5	0	0.002	0.002	--	--	--	--	--
Iron (DIS)	mg/l	5	1	0.02	0.02	0.02	0.02	0.02	0.02	--
Lead (DIS)	mg/l	5	0	0.0003	0.0003	--	--	--	--	--
Manganese (DIS)	mg/l	5	1	0.005	0.01	0.01	0.01	0.01	0.01	--
Mercury (DIS)	mg/l	5	0	0.000005	0.000005	--	--	--	--	--
Molybdenum (DIS)	mg/l	5	0	0.002	0.002	--	--	--	--	--
Nickel (DIS)	mg/l	5	1	0.001	0.001	0.001	0.001	0.001	0.001	--
Selenium (DIS)	mg/l	5	1	0.0002	0.0002	0.00	0.0002	0.0002	0.0002	--
Silver (DIS)	mg/l	5	0	0.02	0.02	--	--	--	--	--
Strontium (DIS)	mg/l	5	5	0.10	0.11	0.10	0.10	0.11	0.11	0.00
Thallium (DIS)	mg/l	5	0	0.0002	0.0002	--	--	--	--	--
Uranium (DIS)	mg/l	5	0	0.008	0.008	--	--	--	--	--
Zinc (DIS)	mg/l	5	0	0.002	0.002	--	--	--	--	--

MW-14 - Statistical Analysis
Reporting Period - 5/2011 - 12/2016

Parameter	Units	No. Samples	No. Detects	Min.	Max.	Mean	25% PCTL	75% PCTL	95% PCTL	SD.
Depth To Water	ft	2	2	38.35	40.43	39.39	38.87	39.91	40.33	1.47
pH - Field	s.u.	2	2	7.65	7.79	7.72	7.69	7.76	7.78	0.10
Specific Conductance	umhos/cm	2	2	411	464	438	424	451	461	37
Water Temperature	Deg C	2	2	5.4	8.0	6.7	6.1	7.4	7.9	1.8
Dissolved Oxygen	mg/l	2	2	0.49	1.89	1.19	0.84	1.54	1.82	0.99
Total Dissolved Solids	mg/l	1	1	236	236	236	236	236	236	--
Total Suspended Solids	mg/l	1	1	800	800	800	800	800	800	--
Alkalinity as CaCO3	mg/l	1	1	360	360	360	360	360	360	--
Chloride	mg/l	1	1	5.4	5.4	5.4	5.4	5.4	5.4	--
Fluoride	mg/l	1	1	0.6	0.6	0.6	0.6	0.6	0.6	--
Sulfate	mg/l	1	1	15	15	15	15	15	15	--
Total Hardness	mg/l	1	1	226	226	226	226	226	226	--
Calcium (DIS)	mg/l	1	1	41	41	41	41	41	41	--
Magnesium (DIS)	mg/l	1	1	30	30	30	30	30	30	--
Potassium (DIS)	mg/l	1	1	2	2	2	2	2	2	--
Sodium (DIS)	mg/l	1	1	3	3	3	3	3	3	--
Nitrate + Nitrite as n	mg/l	1	1	0.05	0.05	0.05	0.05	0.05	0.05	--
Aluminum (DIS)	mg/l	1	1	0.046	0.046	0.046	0.046	0.046	0.046	--
Antimony (DIS)	mg/l	1	1	0.0008	0.0008	0.0008	0.0008	0.0008	0.0008	--
Arsenic (DIS)	mg/l	1	1	0.002	0.002	0.002	0.002	0.002	0.002	--
Barium (DIS)	mg/l	1	1	0.06	0.06	0.06	0.06	0.06	0.06	--
Beryllium (DIS)	mg/l	1	0	0.0008	0.0008	--	--	--	--	--
Cadmium (DIS)	mg/l	1	0	0.00003	0.00003	--	--	--	--	--
Chromium (DIS)	mg/l	1	0	0.01	0.01	--	--	--	--	--
Cobalt (DIS)	mg/l	1	0	0.01	0.01	--	--	--	--	--
Copper (DIS)	mg/l	1	0	0.002	0.002	--	--	--	--	--
Iron (DIS)	mg/l	1	1	0.02	0.02	0.02	0.02	0.02	0.02	--
Lead (DIS)	mg/l	1	1	0.0007	0.0007	0.0007	0.0007	0.0007	0.0007	--
Manganese (DIS)	mg/l	1	1	0.022	0.022	0.022	0.022	0.022	0.022	--
Mercury (DIS)	mg/l	1	0	0.000005	0.000005	--	--	--	--	--
Molybdenum (DIS)	mg/l	1	1	0.002	0.002	0.002	0.002	0.002	0.002	--
Nickel (DIS)	mg/l	1	1	0.001	0.001	0.001	0.001	0.001	0.001	--
Selenium (DIS)	mg/l	1	1	0.0004	0.0004	0.0004	0.0004	0.0004	0.0004	--
Silver (DIS)	mg/l	1	0	0.02	0.02	--	--	--	--	--
Strontium (DIS)	mg/l	1	1	0.176	0.176	0.176	0.176	0.176	0.176	--
Thallium (DIS)	mg/l	1	0	0.0002	0.0002	--	--	--	--	--
Uranium (DIS)	mg/l	1	0	0.008	0.008	--	--	--	--	--
Zinc (DIS)	mg/l	1	1	0.01	0.01	0.01	0.01	0.01	0.01	--

MW-15 - Statistical Analysis
Reporting Period - 5/2011 - 12/2016

Parameter	Units	No. Samples	No. Detects	Min.	Max.	Mean	25% PCTL	75% PCTL	95% PCTL	SD.
Depth To Water	ft	2	2	39.21	40.11	39.66	39.44	39.89	40.07	0.64
pH - Field	s.u.	2	2	7.45	7.60	7.53	7.49	7.56	7.59	0.11
Specific Conductance	umhos/cm	2	2	458	498	478	468	488	496	28
Water Temperature	Deg C	2	2	6.2	8.9	7.6	6.9	8.2	8.8	1.9
Dissolved Oxygen	mg/l	2	2	0.16	0.38	0.27	0.22	0.33	0.37	0.16
Total Dissolved Solids	mg/l	1	1	257	257	257	257	257	257	--
Total Suspended Solids	mg/l	1	1	17	17	17	17	17	17	--
Alkalinity as CaCO3	mg/l	1	1	230	230	230	230	230	230	--
Chloride	mg/l	1	1	1.3	1.3	1.3	1.3	1.3	1.3	--
Fluoride	mg/l	1	1	0.4	0.4	0.4	0.4	0.4	0.4	--
Sulfate	mg/l	1	1	22	22	22	22	22	22	--
Total Hardness	mg/l	1	1	257	257	257	257	257	257	--
Calcium (DIS)	mg/l	1	1	47	47	47	47	47	47	--
Magnesium (DIS)	mg/l	1	1	34	34	34	34	34	34	--
Potassium (DIS)	mg/l	1	1	2	2	2	2	2	2	--
Sodium (DIS)	mg/l	1	1	3	3	3	3	3	3	--
Nitrate + Nitrite as n	mg/l	1	0	0.01	0.01	--	--	--	--	--
Aluminum (DIS)	mg/l	1	1	0.045	0.045	0.045	0.045	0.045	0.045	--
Antimony (DIS)	mg/l	1	0	0.0005	0.0005	--	--	--	--	--
Arsenic (DIS)	mg/l	1	1	0.004	0.004	0.0040	0.004	0.004	0.004	--
Barium (DIS)	mg/l	1	1	0.051	0.051	0.05	0.051	0.051	0.051	--
Beryllium (DIS)	mg/l	1	0	0.0008	0.0008	--	--	--	--	--
Cadmium (DIS)	mg/l	1	0	0.00003	0.00003	--	--	--	--	--
Chromium (DIS)	mg/l	1	0	0.01	0.01	--	--	--	--	--
Cobalt (DIS)	mg/l	1	0	0.01	0.01	--	--	--	--	--
Copper (DIS)	mg/l	1	0	0.002	0.002	--	--	--	--	--
Iron (DIS)	mg/l	1	1	0.17	0.17	0.17	0.17	0.17	0.17	--
Lead (DIS)	mg/l	1	0	0.0003	0.0003	--	--	--	--	--
Manganese (DIS)	mg/l	1	1	0.032	0.032	0.032	0.032	0.032	0.032	--
Mercury (DIS)	mg/l	1	0	0.000005	0.000005	--	--	--	--	--
Molybdenum (DIS)	mg/l	1	0	0.002	0.002	--	--	--	--	--
Nickel (DIS)	mg/l	1	0	0.001	0.001	--	--	--	--	--
Selenium (DIS)	mg/l	1	0	0.0002	0.0002	--	--	--	--	--
Silver (DIS)	mg/l	1	0	0.02	0.02	--	--	--	--	--
Strontium (DIS)	mg/l	1	1	0.168	0.168	0.168	0.168	0.168	0.168	--
Thallium (DIS)	mg/l	1	0	0.0002	0.0002	--	--	--	--	--
Uranium (DIS)	mg/l	1	0	0.008	0.008	--	--	--	--	--
Zinc (DIS)	mg/l	1	1	0.009	0.009	0.009	0.009	0.009	0.009	--

DS-2 - Statistical Analysis
Reporting Period - 5/2011 - 12/2016

Parameter	Units	No. Samples	No. Detects	Min.	Max.	Mean	25% PCTL	75% PCTL	95% PCTL	SD.
Flow	gallons per min	7	5	0.002	11.7	2.9	0.4	1.8	9.7	4.4
pH - Field	s.u.	6	6	6.45	7.95	7.28	6.89	7.78	7.94	0.55
Specific Conductance	umhos/cm	6	6	331	392	365	338	390	392	27
Water Temperature	Deg C	6	6	5.73	17.4	13.2	12.8	15.9	17.2	3.8
Dissolved Oxygen	mg/l	6	6	3.42	9.58	7.13	4.97	9.38	9.56	2.48
Total Dissolved Solids	mg/l	2	2	182	200	191	187	196	199	9
Total Suspended Solids	mg/l	1	0	<10	--	--	--	--	--	--
Alkalinity as CaCO3	mg/l	2	2	180	200	190	185	195	199	10
Bicarbonate as HCO3	mg/l	1	1	240	240	--	--	--	--	--
Carbonate as CO3	mg/l	1	0	<1	--	--	--	--	--	--
Chloride	mg/l	2	1	<1	2	2	2	2	2	0
Fluoride	mg/l	2	0	<0.1	--	--	--	--	--	--
Sulfate	mg/l	2	2	3	4	4	3	4	4	1
Total Hardness	mg/l	2	2	167	188	178	172	183	187	11
Calcium (DIS)	mg/l	2	2	34	36	35	35	36	36	1
Magnesium (DIS)	mg/l	2	2	20	24	22	21	23	24	2
Potassium (DIS)	mg/l	2	2	1	1	--	--	--	--	--
Sodium (DIS)	mg/l	2	2	3	3	3	3	3	3	0
Nitrate + Nitrite as n	mg/l	2	2	0.02	0.04	0.03	0.03	0.04	0.04	0.01
Aluminum (DIS)	mg/l	2	0	<0.009	--	--	--	--	--	--
Antimony (DIS)	mg/l	2	0	<0.0005	--	--	--	--	--	--
Arsenic (DIS)	mg/l	2	0	<0.001	--	--	--	--	--	--
Barium (DIS)	mg/l	2	2	0.332	0.341	0.337	0.334	0.339	0.341	0.005
Beryllium (DIS)	mg/l	2	0	<0.0008	--	--	--	--	--	--
Cadmium (DIS)	mg/l	2	0	<0.00003	--	--	--	--	--	--
Chromium (DIS)	mg/l	2	0	<0.001	--	--	--	--	--	--
Cobalt (DIS)	mg/l	2	0	<0.005	--	--	--	--	--	--
Copper (DIS)	mg/l	2	0	<0.001	--	--	--	--	--	--
Iron (DIS)	mg/l	2	2	0.09	0.13	0.11	0.10	0.12	0.13	0.02
Lead (DIS)	mg/l	2	0	<0.0003	--	--	--	--	--	--
Manganese (DIS)	mg/l	2	2	0.018	0.042	0.030	0.024	0.036	0.041	0.012
Mercury (DIS)	mg/l	2	0	<0.000005	--	--	--	--	--	--
Molybdenum (DIS)	mg/l	2	1	<0.005	0.001	--	--	--	--	--
Nickel (DIS)	mg/l	2	0	<0.001	--	--	--	--	--	--
Selenium (DIS)	mg/l	2	0	<0.0002	--	--	--	--	--	--
Silver (DIS)	mg/l	2	0	<0.0005	--	--	--	--	--	--
Strontium (DIS)	mg/l	2	1	<0.1	0.0646	--	--	--	--	--
Thallium (DIS)	mg/l	2	0	<0.0002	--	--	--	--	--	--
Uranium (DIS)	mg/l	2	2	0.0004	0.0007	0.0006	0.0005	0.0006	0.0007	0.0002
Zinc (DIS)	mg/l	2	1	<0.01	0.014	--	--	--	--	--

DS-3 - Statistical Analysis
Reporting Period - 5/2011 - 12/2016

Parameter	Units	No. Samples	No. Detects	Min.	Max.	Mean	25% PCTL	75% PCTL	95% PCTL	SD.
Flow	gallons per min	32	24	--	22.0	6.9	0.9	10.6	19.2	6.8
pH - Field	s.u.	26	26	5.46	8.46	6.92	6.00	7.66	8.30	0.95
Specific Conductance	umhos/cm	26	26	42	132	60	50	59	116	21
Water Temperature	Deg C	26	26	3.8	14.4	8.9	7.3	10.5	13.7	2.6
Dissolved Oxygen	mg/l	26	26	3.72	11.56	7.09	5.05	8.96	10.75	2.38
Total Dissolved Solids	mg/l	19	19	47	117	71	56	78	113	21
Total Suspended Solids	mg/l	19	4	9	95	45	11	73	91	36
Alkalinity as CaCO3	mg/l	19	19	17	29	23	22	25	28	3
Chloride	mg/l	19	3	<1	1	1	1	1	1	0
Fluoride	mg/l	19	2	0.04	0.04	0.04	0.04	0.04	0.04	0.00
Sulfate	mg/l	19	19	1	2	1	1	2	2	0
Total Hardness	mg/l	19	19	21	26	24	23	23	26	1
Calcium (DIS)	mg/l	19	19	5	7	6	6	6	7	0
Magnesium (DIS)	mg/l	19	19	2	2	2	2	2	2	0
Potassium (DIS)	mg/l	19	18	<1	2	1	1	1	1	0
Sodium (DIS)	mg/l	19	19	1	2	--	--	--	--	--
Nitrate + Nitrite as n	mg/l	19	19	0.19	0.48	0.30	0.22	0.36	0.45	0.08
Aluminum (DIS)	mg/l	19	19	0.391	4.64	1.89	0.79	2.73	4.15	1.29
Antimony (DIS)	mg/l	18	0	<0.0005	--	--	--	--	--	--
Antimony (TRC)	mg/l	1	0	<0.0005	--	--	--	--	--	--
Arsenic (DIS)	mg/l	18	4	<0.001	0.002	0.001	0.001	0.001	0.002	0.000
Arsenic (TRC)	mg/l	1	1	0.001	0.001	0.001	0.001	0.001	0.001	0.000
Barium (DIS)	mg/l	18	18	0.259	0.345	0.284	0.273	0.290	0.319	0.020
Barium (TRC)	mg/l	1	1	0.276	0.276	--	--	--	--	--
Beryllium (DIS)	mg/l	18	0	<0.0008	--	--	--	--	--	--
Beryllium (TRC)	mg/l	1	0	<0.0008	--	--	--	--	--	--
Cadmium (DIS)	mg/l	18	2	<0.00003	0.00003	0.00003	0.00003	0.00003	0.00003	0.00000
Cadmium (TRC)	mg/l	1	0	<0.00003	--	--	--	--	--	--
Chromium (DIS)	mg/l	18	0	<0.005	--	--	--	--	--	--
Chromium (TRC)	mg/l	1	0	<0.01	--	--	--	--	--	--
Cobalt (DIS)	mg/l	18	0	<0.005	--	--	--	--	--	--
Cobalt (TRC)	mg/l	1	0	<0.01	--	--	--	--	--	--
Copper (DIS)	mg/l	18	11	<0.002	0.004	0.003	0.002	0.003	0.004	0.001
Copper (TRC)	mg/l	1	1	0.004	0.004	0.004	0.004	0.004	0.004	0.000
Iron (DIS)	mg/l	18	18	0.18	2.78	0.94	0.37	1.39	2.44	0.73
Iron (TRC)	mg/l	1	1	1.87	1.87	--	--	--	--	--
Lead (DIS)	mg/l	18	8	<0.0003	0.001	0.000	0.000	0.001	0.001	0.000
Lead (TRC)	mg/l	1	1	0.0007	0.0007	--	--	--	--	--
Manganese (DIS)	mg/l	18	15	<0.001	0.024	0.007	0.003	0.010	0.019	0.006
Manganese (TRC)	mg/l	1	1	0.01	0.013	0.013	0.013	0.013	0.013	0.000
Mercury (DIS)	mg/l	18	9	<0.000005	0.0000173	0.0000082	0.0000055	0.0000106	0.0000148	0.0000042
Mercury (TRC)	mg/l	1	1	0.00	0.0000102	--	--	--	--	--
Molybdenum (DIS)	mg/l	18	0	<0.002	--	--	--	--	--	--
Molybdenum (TRC)	mg/l	1	0	<0.002	--	--	--	--	--	--
Nickel (DIS)	mg/l	18	17	<0.001	0.006	0.003	0.003	0.003	0.006	0.001
Nickel (TRC)	mg/l	1	1	0.01	0.005	--	--	--	--	--
Selenium (DIS)	mg/l	18	5	<0.0002	0.0002	0.0002	0.0002	0.0002	0.0002	0.0000
Selenium (TRC)	mg/l	1	0	<0.0002	--	--	--	--	--	--
Silicon (DIS)	mg/l	1	1	23.70	23.7	--	--	--	--	--
Silver (DIS)	mg/l	18	0	<0.001	--	--	--	--	--	--
Silver (TRC)	mg/l	1	0	<0.02	--	--	--	--	--	--
Strontium (DIS)	mg/l	18	18	0.03	0.0324	0.03	0.03	0.03	0.03	0.00
Strontium (TRC)	mg/l	1	1	0.03	0.0275	0.03	0.03	0.03	0.03	0.00
Thallium (DIS)	mg/l	18	0	<0.0002	--	--	--	--	--	--
Thallium (TRC)	mg/l	1	0	<0.0002	--	--	--	--	--	--
Uranium (DIS)	mg/l	18	0	<0.0003	--	--	--	--	--	--
Uranium (TRC)	mg/l	1	0	<0.008	--	--	--	--	--	--
Zinc (DIS)	mg/l	18	15	<0.002	0.013	0.005	0.003	0.006	0.012	0.003
Zinc (TRC)	mg/l	1	1	0.01	0.01	--	--	--	--	--

DS-4 - Statistical Analysis
Reporting Period - 5/2011 - 12/2016

Parameter	Units	No. Samples	No. Detects	Min.	Max.	Mean	25% PCTL	75% PCTL	95% PCTL	SD.
Flow	gallons per min	31	9	--	19.7	4.8	2.0	4.0	14.8	5.6
pH - Field	s.u.	24	24	5.86	8.83	7.15	6.60	7.69	8.22	0.70
Specific Conductance	umhos/cm	24	24	8.32	203	107	91	119	159	35
Water Temperature	Deg C	24	24	0.2	20.24	9.5	6.3	12.0	19.3	4.6
Dissolved Oxygen	mg/l	23	23	2.45	11.98	7.30	5.67	8.94	11.03	2.23
Total Dissolved Solids	mg/l	19	19	60	122	92	83	106	118	16
Total Suspended Solids	mg/l	18	11	<10	868	197	62	203	642	240
Alkalinity as CaCO3	mg/l	19	19	37	84	50	43	53	67	10
Bicarbonate as HCO3	mg/l	1	1	63	63	--	--	--	--	--
Carbonate as CO3	mg/l	1	0	<1	--	--	--	--	--	--
Chloride	mg/l	19	4	<1	2	2	1	2	2	1
Fluoride	mg/l	19	8	<0.1	0.1	0	0	0	0	0
Sulfate	mg/l	19	18	<1	4	2	2	3	3	1
Total Hardness	mg/l	19	19	38	71	49	46	52	61	7
Calcium (DIS)	mg/l	19	19	11	22	15	14	16	19	2
Magnesium (DIS)	mg/l	19	19	2	4	3	3	3	4	0
Potassium (DIS)	mg/l	19	9	<1	2	1	1	1	2	0
Sodium (DIS)	mg/l	19	19	1	2	1	1	2	2	0
Nitrate + Nitrite as n	mg/l	19	14	<0.01	0.47	0.23	0.08	0.34	0.40	0.14
Aluminum (DIS)	mg/l	19	17	<0.009	3.82	0.93	0.07	0.75	3.68	1.32
Antimony (DIS)	mg/l	18	1	0.0001	0.0001	--	--	--	--	--
Antimony (TRC)	mg/l	1	0	<0.0005	--	--	--	--	--	--
Arsenic (DIS)	mg/l	18	12	<0.001	0.004	0.002	0.002	0.003	0.003	0.001
Arsenic (TRC)	mg/l	1	1	0.001	0.001	--	--	--	--	--
Barium (DIS)	mg/l	18	18	0.241	0.428	0.314	0.273	0.349	0.379	0.047
Barium (TRC)	mg/l	1	1	0.255	0.255	--	--	--	--	--
Beryllium (DIS)	mg/l	18	0	<0.001	--	--	--	--	--	--
Beryllium (TRC)	mg/l	1	0	<0.0008	--	--	--	--	--	--
Cadmium (DIS)	mg/l	18	0	<0.00003	--	--	--	--	--	--
Cadmium (TRC)	mg/l	1	0	<0.00003	--	--	--	--	--	--
Chromium (DIS)	mg/l	18	0	<0.01	--	--	--	--	--	--
Chromium (TRC)	mg/l	1	0	<0.01	--	--	--	--	--	--
Cobalt (DIS)	mg/l	18	2	<0.005	0.001	0.001	0.001	0.001	0.001	0.000
Cobalt (TRC)	mg/l	1	0	<0.01	--	--	--	--	--	--
Copper (DIS)	mg/l	18	4	<0.002	0.004	0.003	0.003	0.003	0.004	0.001
Copper (TRC)	mg/l	1	0	<0.002	--	--	--	--	--	--
Iron (DIS)	mg/l	18	17	<0.02	2.17	0.74	0.24	1.11	2.11	0.70
Iron (TRC)	mg/l	1	1	0.47	0.47	--	--	--	--	--
Lead (DIS)	mg/l	18	4	<0.0003	0.0011	0.0008	0.0007	0.0009	0.0011	0.0002
Lead (TRC)	mg/l	1	0	<0.0003	--	--	--	--	--	--
Manganese (DIS)	mg/l	18	18	0.007	0.86	0.11	0.01	0.11	0.40	0.20
Manganese (TRC)	mg/l	1	1	0.018	0.018	--	--	--	--	--
Mercury (DIS)	mg/l	17	4	<0.00001	0.00001	0.00001	0.00001	0.00001	0.00001	0.00000
Mercury (TRC)	mg/l	2	0	<0.000005	--	--	--	--	--	--
Molybdenum (DIS)	mg/l	18	0	<0.001	--	--	--	--	--	--
Molybdenum (TRC)	mg/l	1	0	<0.002	--	--	--	--	--	--
Nickel (DIS)	mg/l	18	17	0.001	0.004	0.002	0.001	0.002	0.004	0.001
Nickel (TRC)	mg/l	1	1	0.002	0.002	--	--	--	--	--
Selenium (DIS)	mg/l	18	0	<0.001	--	--	--	--	--	--
Selenium (TRC)	mg/l	1	0	<0.0002	--	--	--	--	--	--
Silicon (DIS)	mg/l	1	1	27.7	27.7	--	--	--	--	--
Silver (DIS)	mg/l	18	0	<0.001	--	--	--	--	--	--
Silver (TRC)	mg/l	1	0	<0.02	--	--	--	--	--	--
Strontium (DIS)	mg/l	18	17	0.0408	0.0702	0.0490	0.0448	0.0513	0.0611	0.0071
Strontium (TRC)	mg/l	1	1	0.0398	0.0398	--	--	--	--	--
Thallium (DIS)	mg/l	18	0	<0.0002	--	--	--	--	--	--
Thallium (TRC)	mg/l	1	0	<0.0002	--	--	--	--	--	--
Uranium (DIS)	mg/l	18	0	<0.0003	--	--	--	--	--	--
Uranium (TRC)	mg/l	1	0	<0.008	--	--	--	--	--	--
Zinc (DIS)	mg/l	18	11	<0.002	0.012	0.006	0.004	0.009	0.011	0.003
Zinc (TRC)	mg/l	1	1	0.003	0.003	--	--	--	--	--

DS-5 - Statistical Analysis
Reporting Period - 5/2011 - 12/2016

Parameter	Units	No. Samples	No. Detects	Min.	Max.	Mean	25% PCTL	75% PCTL	95% PCTL	SD.
Flow	gallons per min	7	5	--	17.9	5.3	1.4	4.5	15.2	6.4
pH - Field	s.u.	6	6	6.44	7.81	7.13	6.85	7.47	7.74	0.46
Specific Conductance	umhos/cm	6	6	206	232	217	211	221	230	9
Water Temperature	Deg C	6	6	7.1	9.7	8.5	7.5	9.4	9.7	1.0
Dissolved Oxygen	mg/l	6	6	8.41	12.62	9.88	8.60	10.58	12.16	1.49

DS-6 - Statistical Analysis
Reporting Period - 5/2011 - 12/2016

Parameter	Units	No. Samples	No. Detects	Min.	Max.	Mean	25% PCTL	75% PCTL	95% PCTL	SD.
Flow	gallons per min	6	6	0.22	17.9	3.8	0.4	2.8	14.3	6.4
pH - Field	s.u.	6	6	5.9	6.60	6.26	6.13	6.36	6.54	0.22
Specific Conductance	umhos/cm	6	6	75	142	92	79	92	130	23
Water Temperature	Deg C	6	6	5.64	12.8	10.7	9.4	12.6	12.8	2.7
Dissolved Oxygen	mg/l	6	6	2	6.42	5.06	4.52	6.23	6.39	1.55

SP-1 - Statistical Analysis
Reporting Period - 5/2011 - 12/2016

Parameter	Units	No. Samples	No. Detects	Min.	Max.	Mean	25% PCTL	75% PCTL	95% PCTL	SD.
Flow	gallons per min	11	7	1.39	64.6	17.8	2.8	22.2	54.6	21.4
pH - Field	s.u.	11	11	7.36	7.83	7.67	7.62	7.76	7.82	0.14
Specific Conductance	umhos/cm	11	11	349	489	414	393	428	461	36
Water Temperature	Deg C	11	11	1.1	13.25	6.9	5.8	8.5	11.6	3.3
Dissolved Oxygen	mg/l	11	11	0.3	13.3	8.30	6.75	11.30	13.30	3.92
Total Dissolved Solids	mg/l	6	6	202	256	226	213	235	251	18
Total Suspended Solids	mg/l	3	2	<10	270	153	94	211	258	118
Alkalinity as CaCO3	mg/l	6	6	170	240	203	185	218	235	24
Bicarbonate as HCO3	mg/l	2	2	210	270	240	225	255	267	30
Carbonate as CO3	mg/l	3	1	<1	6	--	--	--	--	--
Chloride	mg/l	6	1	<1	1	--	--	--	--	--
Fluoride	mg/l	6	6	0.1	0.2	0.2	0.2	0.2	0.2	0.0
Sulfate	mg/l	6	6	6	21	15	15	17	20	5
Total Hardness	mg/l	6	6	180	237	213	200	225	235	20
Calcium (DIS)	mg/l	6	6	39	52	45	42	48	51	4
Magnesium (DIS)	mg/l	6	6	20	26	24	23	26	26	2
Potassium (DIS)	mg/l	6	3	<1	2	1.33	1.00	1.50	1.90	0.47
Sodium (DIS)	mg/l	6	6	1	2	1	1	1	2	0
Nitrate + Nitrite as n	mg/l	6	4	<0.01	0.09	0.07	0.06	0.09	0.09	0.03
Aluminum (DIS)	mg/l	6	2	<0.009	0.021	0.016	0.013	0.018	0.020	0.006
Aluminum (TRC)	mg/l	1	1	0.19	0.19	--	--	--	--	--
Antimony (DIS)	mg/l	5	0	<0.0005	--	--	--	--	--	--
Antimony (TRC)	mg/l	1	0	<0.003	--	--	--	--	--	--
Arsenic (DIS)	mg/l	5	0	<0.001	--	--	--	--	--	--
Arsenic (TRC)	mg/l	1	0	<0.003	--	--	--	--	--	--
Barium (DIS)	mg/l	5	5	0.093	0.121	0.111	0.106	0.121	0.121	0.011
Barium (TRC)	mg/l	1	1	0.128	0.128	--	--	--	--	--
Beryllium (DIS)	mg/l	5	0	<0.0008	--	--	--	--	--	--
Beryllium (TRC)	mg/l	1	0	<0.001	--	--	--	--	--	--
Cadmium (DIS)	mg/l	5	0	<0.00003	--	--	--	--	--	--
Cadmium (TRC)	mg/l	1	0	<0.00008	--	--	--	--	--	--
Chromium (DIS)	mg/l	5	0	<0.001	--	--	--	--	--	--
Chromium (TRC)	mg/l	1	0	<0.001	--	--	--	--	--	--
Cobalt (DIS)	mg/l	5	0	<0.005	--	--	--	--	--	--
Cobalt (TRC)	mg/l	1	0	<0.01	--	--	--	--	--	--
Copper (DIS)	mg/l	5	0	<0.001	--	--	--	--	--	--
Copper (TRC)	mg/l	1	1	0.001	0.001	--	--	--	--	--
Iron (DIS)	mg/l	5	4	<0.02	0.69	0.22	0.06	0.23	0.60	0.27
Iron (TRC)	mg/l	1	1	1.81	1.81	--	--	--	--	--
Lead (DIS)	mg/l	5	0	<0.0005	--	--	--	--	--	--
Lead (TRC)	mg/l	1	1	0.0008	0.0008	--	--	--	--	--
Manganese (DIS)	mg/l	5	5	0.005	0.325	0.091	0.032	0.060	0.272	0.118
Manganese (TRC)	mg/l	1	1	0.091	0.091	--	--	--	--	--
Mercury (DIS)	mg/l	5	0	<0.000005	--	--	--	--	--	--
Mercury (TRC)	mg/l	1	0	<0.00001	--	--	--	--	--	--
Molybdenum (DIS)	mg/l	5	0	<0.001	--	--	--	--	--	--
Molybdenum (TRC)	mg/l	1	0	<0.005	--	--	--	--	--	--
Nickel (DIS)	mg/l	5	0	<0.001	--	--	--	--	--	--
Nickel (TRC)	mg/l	1	0	<0.01	--	--	--	--	--	--
Selenium (DIS)	mg/l	5	1	<0.001	0.0003	--	--	--	--	--
Selenium (TRC)	mg/l	1	0	<0.001	--	--	--	--	--	--
Silver (DIS)	mg/l	5	0	<0.0005	--	--	--	--	--	--
Silver (TRC)	mg/l	1	0	<0.0005	--	--	--	--	--	--
Strontium (DIS)	mg/l	5	3	0.0592	0.0701	0.0655	0.0632	0.0687	0.0698	0.0046
Strontium (TRC)	mg/l	1	0	<0.1	--	--	--	--	--	--
Thallium (DIS)	mg/l	5	0	<0.0002	--	--	--	--	--	--
Thallium (TRC)	mg/l	1	0	<0.0002	--	--	--	--	--	--
Uranium (DIS)	mg/l	5	3	0.0004	0.0005	0.0005	0.0005	0.0005	0.0005	0.0000
Uranium (TRC)	mg/l	1	1	0.0004	0.0004	--	--	--	--	--
Zinc (DIS)	mg/l	5	0	<0.002	--	--	--	--	--	--
Zinc (TRC)	mg/l	1	0	<0.01	--	--	--	--	--	--

SP-2 - Statistical Analysis
Reporting Period - 5/2011 - 12/2016

Parameter	Units	No. Samples	No. Detects	Min.	Max.	Mean	25% PCTL	75% PCTL	95% PCTL	SD.
Flow	gallons per min	9	7	--	9.4	4.5	1.4	8.0	9.0	3.5
pH - Field	s.u.	8	8	6.93	8.14	7.56	7.06	7.96	8.09	0.45
Specific Conductance	umhos/cm	8	8	296	418	346	313	372	407	40
Water Temperature	Deg C	8	8	6.5	17.9	12.7	10.9	15.7	17.6	3.6
Dissolved Oxygen	mg/l	8	8	3.81	9.64	6.62	5.08	8.12	9.19	2.02
Total Dissolved Solids	mg/l	5	5	181	232	204	185	210	228	19
Total Suspended Solids	mg/l	2	2	38	342	190	114	266	327	152
Alkalinity as CaCO3	mg/l	5	5	150	210	184	180	190	206	20
Bicarbonate as HCO3	mg/l	2	2	230	230	230	230	230	230	0
Carbonate as CO3	mg/l	3	3	2	4	3	2	3	4	1
Chloride	mg/l	5	3	<1	1	--	--	--	--	--
Fluoride	mg/l	5	5	0.1	0.2	0	0	0	0	0
Sulfate	mg/l	5	5	2	11	5	3	6	10	3
Total Hardness	mg/l	5	5	159	210	186	176	196	207	17
Calcium (DIS)	mg/l	5	5	39	51	46	44	49	51	4
Magnesium (DIS)	mg/l	5	5	15	20	17	16	18	20	2
Potassium (DIS)	mg/l	5	0	<1	--	--	--	--	--	--
Sodium (DIS)	mg/l	5	5	2	2	2	2	2	2	0
Nitrate + Nitrite as n	mg/l	5	5	0.03	0.16	0.06	0.03	0.04	0.14	0.05
Aluminum (DIS)	mg/l	5	0	<0.009	--	--	--	--	--	--
Antimony (DIS)	mg/l	5	0	<0.0005	--	--	--	--	--	--
Arsenic (DIS)	mg/l	5	0	<0.001	--	--	--	--	--	--
Barium (DIS)	mg/l	5	5	0.076	0.153	0.099	0.076	0.109	0.144	0.030
Beryllium (DIS)	mg/l	5	0	<0.0008	--	--	--	--	--	--
Cadmium (DIS)	mg/l	5	0	<0.00003	--	--	--	--	--	--
Chromium (DIS)	mg/l	5	0	<0.001	--	--	--	--	--	--
Cobalt (DIS)	mg/l	5	0	<0.005	--	--	--	--	--	--
Copper (DIS)	mg/l	5	0	<0.001	--	--	--	--	--	--
Iron (DIS)	mg/l	5	4	<0.02	0.11	0.07	0.06	0.07	0.10	0.03
Lead (DIS)	mg/l	5	0	<0.0005	--	--	--	--	--	--
Manganese (DIS)	mg/l	5	4	<0.005	0.068	0.043	0.033	0.046	0.064	0.015
Mercury (DIS)	mg/l	5	0	<0.000005	--	--	--	--	--	--
Molybdenum (DIS)	mg/l	5	0	<0.001	--	--	--	--	--	--
Nickel (DIS)	mg/l	5	0	<0.001	--	--	--	--	--	--
Selenium (DIS)	mg/l	5	0	<0.0002	--	--	--	--	--	--
Silver (DIS)	mg/l	5	0	<0.0005	--	--	--	--	--	--
Strontium (DIS)	mg/l	5	2	0.0676	0.0842	0.0759	0.0718	0.0801	0.0834	0.0083
Thallium (DIS)	mg/l	5	1	<0.0002	0.0004	--	--	--	--	--
Uranium (DIS)	mg/l	5	4	0.0003	0.0005	0.0004	0.0004	0.0004	0.0005	0.0001
Zinc (DIS)	mg/l	5	0	<0.002	--	--	--	--	--	--

SP-2B - Statistical Analysis
Reporting Period - 5/2011 - 12/2016

Parameter	Units	No. Samples	No. Detects	Min.	Max.	Mean	25% PCTL	75% PCTL	95% PCTL	SD.
Flow	gallons per min	1	1	0.045	0.045	--	--	--	--	--
pH - Field	s.u.	1	1	7.82	7.82	--	--	--	--	--
Specific Conductance	umhos/cm	1	1	341	341	--	--	--	--	--
Water Temperature	Deg C	1	1	4.64	4.64	--	--	--	--	--
Dissolved Oxygen	mg/l	1	1	13.67	13.67	--	--	--	--	--
Total Dissolved Solids	mg/l	1	1	198	198	--	--	--	--	--
Alkalinity as CaCO3	mg/l	1	1	180	180	--	--	--	--	--
Bicarbonate as HCO3	mg/l	1	1	220	220	--	--	--	--	--
Carbonate as CO3	mg/l	1	1	2	2	--	--	--	--	--
Chloride	mg/l	1	0	<1	--	--	--	--	--	--
Fluoride	mg/l	1	1	0.2	0.2	--	--	--	--	--
Sulfate	mg/l	1	1	7	7	--	--	--	--	--
Total Hardness	mg/l	1	1	175	175	--	--	--	--	--
Calcium (DIS)	mg/l	1	1	39	39	--	--	--	--	--
Magnesium (DIS)	mg/l	1	1	19	19	--	--	--	--	--
Potassium (DIS)	mg/l	1	1	1	1	--	--	--	--	--
Sodium (DIS)	mg/l	1	1	2	2	--	--	--	--	--
Nitrate + Nitrite as n	mg/l	1	1	0.05	0.05	--	--	--	--	--
Aluminum (DIS)	mg/l	1	0	<0.03	--	--	--	--	--	--
Antimony (DIS)	mg/l	1	0	<0.003	--	--	--	--	--	--
Arsenic (DIS)	mg/l	1	0	<0.003	--	--	--	--	--	--
Barium (DIS)	mg/l	1	1	0.102	0.102	--	--	--	--	--
Beryllium (DIS)	mg/l	1	0	<0.001	--	--	--	--	--	--
Cadmium (DIS)	mg/l	1	0	<0.00008	--	--	--	--	--	--
Chromium (DIS)	mg/l	1	0	<0.001	--	--	--	--	--	--
Cobalt (DIS)	mg/l	1	0	<0.01	--	--	--	--	--	--
Copper (DIS)	mg/l	1	0	<0.001	--	--	--	--	--	--
Iron (DIS)	mg/l	1	1	0.06	0.06	--	--	--	--	--
Lead (DIS)	mg/l	1	0	<0.0005	--	--	--	--	--	--
Manganese (DIS)	mg/l	1	1	0.019	0.019	--	--	--	--	--
Mercury (DIS)	mg/l	1	0	<0.00001	--	--	--	--	--	--
Molybdenum (DIS)	mg/l	1	0	<0.005	--	--	--	--	--	--
Nickel (DIS)	mg/l	1	0	<0.01	--	--	--	--	--	--
Selenium (DIS)	mg/l	1	0	<0.001	--	--	--	--	--	--
Silver (DIS)	mg/l	1	0	<0.0005	--	--	--	--	--	--
Strontium (DIS)	mg/l	1	0	<0.1	--	--	--	--	--	--
Thallium (DIS)	mg/l	1	0	<0.0002	--	--	--	--	--	--
Uranium (DIS)	mg/l	1	1	0.0004	0.0004	--	--	--	--	--
Zinc (DIS)	mg/l	1	0	<0.01	--	--	--	--	--	--

SP-3 - Statistical Analysis
Reporting Period - 5/2011 - 12/2016

Parameter	Units	No. Samples	No. Detects	Min.	Max.	Mean	25% PCTL	75% PCTL	95% PCTL	SD.
Flow	gallons per min	26	20	--	5.39	1.89	0.42	3.40	5.39	1.79
pH - Field	s.u.	22	22	6.2	8.18	7.53	7.30	7.91	8.11	0.51
Specific Conductance	umhos/cm	22	22	102	223	163	130	205	220	39
Water Temperature	Deg C	22	22	0.79	13.9	7.3	3.9	9.8	12.7	3.5
Dissolved Oxygen	mg/l	22	22	5.41	12.2	9.72	9.17	10.48	11.96	1.46
Total Dissolved Solids	mg/l	17	17	124	214	144	130	144	184	23
Total Suspended Solids	mg/l	15	9	<10	602	153	37	164	438	168
Alkalinity as CaCO3	mg/l	17	17	50	100	83	67	100	100	19
Bicarbonate as HCO3	mg/l	2	2	110	120	115	112.5	117.5	119.5	5
Carbonate as CO3	mg/l	3	0	<1	--	--	--	--	--	--
Chloride	mg/l	17	3	<1	2	1	1	2	2	0
Fluoride	mg/l	17	17	0.1	0.1	0	0	0	0	0
Sulfate	mg/l	17	17	3	7	5	4	6	7	1
Total Hardness	mg/l	16	16	56	109	84	71	97	107	17
Calcium (DIS)	mg/l	17	17	16	32	25	21	29	32	5
Magnesium (DIS)	mg/l	17	17	4	7	6	5	6	7	1
Potassium (DIS)	mg/l	17	17	1	3	1.53	1.00	2.00	2.20	0.61
Sodium (DIS)	mg/l	17	17	2	3	3	2	3	3	0
Nitrate + Nitrite as n	mg/l	17	17	0.2	0.43	0.30	0.27	0.33	0.37	0.06
Aluminum (DIS)	mg/l	17	17	0.037	3.95	0.77	0.06	0.98	3.14	1.14
Antimony (DIS)	mg/l	16	0	<0.0005	--	--	--	--	--	--
Antimony (TRC)	mg/l	1	0	<0.0005	--	--	--	--	--	--
Arsenic (DIS)	mg/l	16	14	0.001	0.003	0.002	0.001	0.002	0.002	0.001
Arsenic (TRC)	mg/l	1	1	0.002	0.002	--	--	--	--	--
Barium (DIS)	mg/l	16	16	0.24	0.327	0.29	0.26	0.32	0.32	0.03
Barium (TRC)	mg/l	1	1	0.246	0.246	--	--	--	--	--
Beryllium (DIS)	mg/l	16	0	<0.0008	--	--	--	--	--	--
Beryllium (TRC)	mg/l	1	0	<0.0008	--	--	--	--	--	--
Cadmium (DIS)	mg/l	16	0	<0.00003	--	--	--	--	--	--
Cadmium (TRC)	mg/l	1	0	<0.00003	--	--	--	--	--	--
Chromium (DIS)	mg/l	16	1	<0.001	0.001	--	--	--	--	--
Chromium (TRC)	mg/l	1	0	<0.01	--	--	--	--	--	--
Cobalt (DIS)	mg/l	16	0	<0.005	--	--	--	--	--	--
Cobalt (TRC)	mg/l	1	0	<0.01	--	--	--	--	--	--
Copper (DIS)	mg/l	16	5	<0.001	0.007	0.004	0.003	0.007	0.007	0.002
Copper (TRC)	mg/l	1	1	0.005	0.005	--	--	--	--	--
Iron (DIS)	mg/l	16	16	0.02	2.55	0.39	0.03	0.29	1.97	0.70
Iron (TRC)	mg/l	1	1	1.36	1.36	--	--	--	--	--
Lead (DIS)	mg/l	16	2	<0.0003	0.0009	0.0009	0.0008	0.0009	0.0009	0.0001
Lead (TRC)	mg/l	1	1	0.0005	0.0005	--	--	--	--	--
Manganese (DIS)	mg/l	16	3	<0.005	0.02	0.01	0.01	0.02	0.02	0.01
Manganese (TRC)	mg/l	1	1	0.011	0.01	--	--	--	--	--
Mercury (DIS)	mg/l	15	3	<0.000005	0.000015	0.000011	0.000009	0.000014	0.000015	0.000004
Mercury (TRC)	mg/l	2	1	<0.000005	0.0000108	--	--	--	--	--
Molybdenum (DIS)	mg/l	16	0	<0.002	--	--	--	--	--	--
Molybdenum (TRC)	mg/l	1	0	<0.002	--	--	--	--	--	--
Nickel (DIS)	mg/l	16	5	<0.001	0.005	0.003	0.001	0.005	0.005	0.002
Nickel (TRC)	mg/l	1	1	0.004	0.004	--	--	--	--	--
Selenium (DIS)	mg/l	16	2	<0.0002	0.0003	0.0003	0.0002	0.0003	0.0003	0.0001
Selenium (TRC)	mg/l	1	1	0.0002	0.0002	--	--	--	--	--
Silver (DIS)	mg/l	16	0	<0.0005	--	--	--	--	--	--
Silver (TRC)	mg/l	1	0	<0.02	--	--	--	--	--	--
Strontium (DIS)	mg/l	16	14	0.0484	0.0894	0.0761	0.0675	0.0865	0.0894	0.0136
Strontium (TRC)	mg/l	1	1	0.0524	0.0524	--	--	--	--	--
Thallium (DIS)	mg/l	16	0	<0.0002	--	--	--	--	--	--
Thallium (TRC)	mg/l	1	0	<0.0002	--	--	--	--	--	--
Uranium (DIS)	mg/l	16	0	<0.0003	--	--	--	--	--	--
Uranium (TRC)	mg/l	1	0	<0.008	--	--	--	--	--	--
Zinc (DIS)	mg/l	16	3	<0.002	0.01	0.01	0.01	0.01	0.01	0.00
Zinc (TRC)	mg/l	1	1	0.009	0.009	--	--	--	--	--

SP-4 - Statistical Analysis
Reporting Period - 5/2011 - 12/2016

Parameter	Units	No. Samples	No. Detects	Min.	Max.	Mean	25% PCTL	75% PCTL	95% PCTL	SD.
Flow	gallons per min	26	22	1.39	26.9	7.6	3.4	9.1	15.2	5.8
pH - Field	s.u.	26	26	6.95	8.05	7.62	7.44	7.75	8.03	0.26
Specific Conductance	umhos/cm	26	26	273	474	420	412	436	445	34
Water Temperature	Deg C	26	26	3.8	12.2	7.1	6.2	8.3	9.1	1.7
Dissolved Oxygen	mg/l	26	26	6.7	13.95	9.62	8.69	9.74	12.49	1.50
Total Dissolved Solids	mg/l	24	24	202	272	245	239	255	267	15
Total Suspended Solids	mg/l	21	11	5	890	106	20	36	483	249
Alkalinity as CaCO3	mg/l	24	24	200	210	201	200	200	210	3
Bicarbonate as HCO3	mg/l	3	3	240	250	243	240	245	249	5
Carbonate as CO3	mg/l	4	2	<1	7	6.0	5.5	6.5	6.9	1.0
Chloride	mg/l	24	13	<1	1	1	1	1	1	0
Fluoride	mg/l	24	24	0.2	0.3	0	0	0	0	0
Sulfate	mg/l	24	24	10	45	34	30	40	43	9
Total Hardness	mg/l	24	24	208	255	234	225	246	253	13
Calcium (DIS)	mg/l	24	24	42	56	50	49	52	54	3
Magnesium (DIS)	mg/l	24	24	24	29	26	25	28	28	1
Potassium (DIS)	mg/l	24	24	1	2	2	2	2	2	0
Sodium (DIS)	mg/l	24	24	2	2	2	2	2	2	0
Nitrate + Nitrite as n	mg/l	24	24	0.22	0.35	0.26	0.24	0.27	0.31	0.03
Aluminum (DIS)	mg/l	24	2	<0.009	0.129	0.071	0.041	0.100	0.123	0.059
Antimony (DIS)	mg/l	23	0	<0.0005	--	--	--	--	--	--
Antimony (TRC)	mg/l	1	0	<0.0005	--	--	--	--	--	--
Arsenic (DIS)	mg/l	23	0	<0.001	--	--	--	--	--	--
Arsenic (TRC)	mg/l	1	0	<0.001	--	--	--	--	--	--
Barium (DIS)	mg/l	23	23	0.102	0.12	0.11	0.11	0.11	0.12	0.00
Barium (TRC)	mg/l	1	1	0.122	0.122	--	--	--	--	--
Beryllium (DIS)	mg/l	23	0	<0.0008	--	--	--	--	--	--
Beryllium (TRC)	mg/l	1	0	<0.0008	--	--	--	--	--	--
Cadmium (DIS)	mg/l	23	1	<0.00003	0.00003	--	--	--	--	--
Cadmium (TRC)	mg/l	1	0	<0.00003	--	--	--	--	--	--
Chromium (DIS)	mg/l	23	0	<0.001	--	--	--	--	--	--
Chromium (TRC)	mg/l	1	0	<0.01	--	--	--	--	--	--
Cobalt (DIS)	mg/l	23	0	<0.01	--	--	--	--	--	--
Cobalt (TRC)	mg/l	1	0	<0.01	--	--	--	--	--	--
Copper (DIS)	mg/l	23	0	<0.001	--	--	--	--	--	--
Copper (TRC)	mg/l	1	0	<0.002	--	--	--	--	--	--
Iron (DIS)	mg/l	23	6	<0.02	0.17	0.08	0.03	0.12	0.16	0.06
Iron (TRC)	mg/l	1	1	0.21	0.21	--	--	--	--	--
Lead (DIS)	mg/l	23	1	<0.0003	0.0006	--	--	--	--	--
Lead (TRC)	mg/l	1	0	<0.0003	--	--	--	--	--	--
Manganese (DIS)	mg/l	23	14	0.004	0.038	0.012	0.006	0.014	0.029	0.009
Manganese (TRC)	mg/l	1	1	0.065	0.065	--	--	--	--	--
Mercury (DIS)	mg/l	22	1	<0.000005	0.00	--	--	--	--	--
Mercury (TRC)	mg/l	2	0	<0.000005	--	--	--	--	--	--
Molybdenum (DIS)	mg/l	23	0	<0.002	--	--	--	--	--	--
Molybdenum (TRC)	mg/l	1	0	<0.002	--	--	--	--	--	--
Nickel (DIS)	mg/l	23	0	<0.001	--	--	--	--	--	--
Nickel (TRC)	mg/l	1	0	<0.001	--	--	--	--	--	--
Selenium (DIS)	mg/l	23	19	<0.0002	0.0005	0.0004	0.0004	0.0004	0.0005	0.0001
Selenium (TRC)	mg/l	1	1	0.0003	0.0003	--	--	--	--	--
Silicon (DIS)	mg/l	1	1	10.5	10.5	--	--	--	--	--
Silver (DIS)	mg/l	23	0	<0.001	--	--	--	--	--	--
Silver (TRC)	mg/l	1	0	<0.02	--	--	--	--	--	--
Strontium (DIS)	mg/l	23	20	0.0672	0.076	0.071	0.070	0.074	0.075	0.003
Strontium (TRC)	mg/l	1	1	0.0764	0.0764	--	--	--	--	--
Thallium (DIS)	mg/l	23	23	0.0002	0.0004	0.0003	0.0003	0.0003	0.0004	0.0001
Thallium (TRC)	mg/l	1	0	<0.0002	--	--	--	--	--	--
Uranium (DIS)	mg/l	23	4	0.0004	0.0005	0.0005	0.0005	0.0005	0.0005	0.0000
Uranium (TRC)	mg/l	1	0	<0.008	--	--	--	--	--	--
Zinc (DIS)	mg/l	23	7	<0.002	0.005	0.003	0.002	0.004	0.005	0.001
Zinc (TRC)	mg/l	1	0	<0.002	--	--	--	--	--	--

SP-6 - Statistical Analysis
Reporting Period - 5/2011 - 12/2016

Parameter	Units	No. Samples	No. Detects	Min.	Max.	Mean	25% PCTL	75% PCTL	95% PCTL	SD.
Flow	gallons per min	31	18	--	3.0	1.2	0.6	1.5	2.4	0.7
pH - Field	s.u.	28	28	5.81	7.89	7.18	6.82	7.69	7.81	0.60
Specific Conductance	umhos/cm	28	28	241	327	270	261	276	293	16
Water Temperature	Deg C	28	28	5.3	10.29	7.5	6.7	8.3	9.3	1.2
Dissolved Oxygen	mg/l	28	28	6.7	282	19.38	8.68	10.00	14.08	50.57
Total Dissolved Solids	mg/l	27	27	145	188	163	157	169	173	9
Total Suspended Solids	mg/l	25	13	<10	216	86	27	121	197	62
Alkalinity as CaCO3	mg/l	27	27	130	160	137	130	140	147	7
Bicarbonate as HCO3	mg/l	3	3	170	200	183	175	190	198	12
Carbonate as CO3	mg/l	3	0	<1	--	--	--	--	--	--
Chloride	mg/l	27	10	<1	2	1	1	1	2	0
Fluoride	mg/l	27	27	0.2	0.2	0	0	0	0	0
Sulfate	mg/l	27	27	7	11	8	7	10	11	2
Total Hardness	mg/l	27	27	129	160	141	137	143	156	7
Calcium (DIS)	mg/l	27	27	32	38	35	34	36	37	1
Magnesium (DIS)	mg/l	27	27	12	16	13	13	13	15	1
Potassium (DIS)	mg/l	27	7	<1	1	1	1	1	1	0
Sodium (DIS)	mg/l	27	27	2	2	2	2	2	2	0
Nitrate + Nitrite as n	mg/l	27	27	0.31	0.68	0.39	0.35	0.39	0.52	0.08
Aluminum (DIS)	mg/l	27	13	0.004	0.142	0.027	0.010	0.022	0.090	0.035
Antimony (DIS)	mg/l	26	0	<0.0005	--	--	--	--	--	--
Antimony (TRC)	mg/l	1	0	<0.0005	--	--	--	--	--	--
Arsenic (DIS)	mg/l	26	0	<0.001	--	--	--	--	--	--
Arsenic (TRC)	mg/l	1	0	<0.001	--	--	--	--	--	--
Barium (DIS)	mg/l	26	26	0.176	0.217	0.192	0.186	0.196	0.205	0.008
Barium (TRC)	mg/l	1	1	0.176	0.176	--	--	--	--	--
Beryllium (DIS)	mg/l	26	0	<0.0008	--	--	--	--	--	--
Beryllium (TRC)	mg/l	1	0	<0.0008	--	--	--	--	--	--
Cadmium (DIS)	mg/l	26	0	<0.00003	--	--	--	--	--	--
Cadmium (TRC)	mg/l	1	0	<0.00003	--	--	--	--	--	--
Chromium (DIS)	mg/l	26	0	<0.001	--	--	--	--	--	--
Chromium (TRC)	mg/l	1	0	<0.01	--	--	--	--	--	--
Cobalt (DIS)	mg/l	26	0	<0.005	--	--	--	--	--	--
Cobalt (TRC)	mg/l	1	0	<0.01	--	--	--	--	--	--
Copper (DIS)	mg/l	26	0	<0.001	--	--	--	--	--	--
Copper (TRC)	mg/l	1	0	<0.002	--	--	--	--	--	--
Iron (DIS)	mg/l	26	8	<0.02	0.13	0.05	0.03	0.06	0.11	0.03
Iron (TRC)	mg/l	1	1	0.04	0.04	--	--	--	--	--
Lead (DIS)	mg/l	26	1	<0.0003	0.0003	--	--	--	--	--
Lead (TRC)	mg/l	1	0	<0.0003	--	--	--	--	--	--
Manganese (DIS)	mg/l	26	4	<0.001	0.033	0.014	0.006	0.018	0.030	0.011
Manganese (TRC)	mg/l	1	0	<0.005	--	--	--	--	--	--
Mercury (DIS)	mg/l	25	1	<0.000005	0.0000053	--	--	--	--	--
Mercury (TRC)	mg/l	2	0	<0.000005	--	--	--	--	--	--
Molybdenum (DIS)	mg/l	26	0	<0.001	--	--	--	--	--	--
Molybdenum (TRC)	mg/l	1	0	<0.002	--	--	--	--	--	--
Nickel (DIS)	mg/l	26	1	<0.001	0.002	--	--	--	--	--
Nickel (TRC)	mg/l	1	0	<0.001	--	--	--	--	--	--
Selenium (DIS)	mg/l	26	9	<0.0002	0.0003	0.0002	0.0002	0.0002	0.0003	0.0000
Selenium (TRC)	mg/l	1	0	<0.0002	--	--	--	--	--	--
Silicon (DIS)	mg/l	1	1	18.7	18.7	--	--	--	--	--
Silver (DIS)	mg/l	26	0	<0.001	--	--	--	--	--	--
Silver (TRC)	mg/l	1	0	<0.02	--	--	--	--	--	--
Strontium (DIS)	mg/l	26	24	0.0683	0.0764	0.0727	0.0710	0.0746	0.0758	0.0021
Strontium (TRC)	mg/l	1	1	0.0676	0.0676	--	--	--	--	--
Thallium (DIS)	mg/l	26	26	0.0004	0.0007	0.0005	0.0005	0.0005	0.0006	0.0001
Thallium (TRC)	mg/l	1	1	0.0004	0.0004	--	--	--	--	--
Uranium (DIS)	mg/l	26	9	<0.0003	0.0005	0.0004	0.0004	0.0004	0.0005	0.0000
Uranium (TRC)	mg/l	1	0	<0.008	--	--	--	--	--	--
Zinc (DIS)	mg/l	26	3	0.001	0.003	0.002	0.002	0.003	0.003	0.001
Zinc (TRC)	mg/l	1	0	<0.002	--	--	--	--	--	--

SP-7 - Statistical Analysis
Reporting Period - 5/2011 - 12/2016

Parameter	Units	No. Samples	No. Detects	Min.	Max.	Mean	25% PCTL	75% PCTL	95% PCTL	SD.
Flow	gallons per min	25	21	9.42	112.2	28.1	13.0	25.1	75.4	25.6
pH - Field	s.u.	25	25	6.17	8.18	7.39	7.22	7.55	8.03	0.37
Specific Conductance	umhos/cm	25	25	244	347	327	324	336	345	19
Water Temperature	Deg C	25	25	5.3	7.4	6.8	6.6	7.1	7.4	0.5
Dissolved Oxygen	mg/l	25	25	2.44	10.98	4.23	2.82	5.05	8.36	2.05
Total Dissolved Solids	mg/l	26	26	175	200	189	185	194	200	7
Total Suspended Solids	mg/l	26	2	<10	146	84	52	115	140	63
Alkalinity as CaCO3	mg/l	26	26	160	170	167	163	170	170	4
Chloride	mg/l	26	26	1	2	2	1	2	2	0
Fluoride	mg/l	26	26	0.3	0.4	0.3	0.3	0.3	0.4	0.0
Sulfate	mg/l	26	26	7	11	9	8	11	11	1
Total Hardness	mg/l	22	22	153	178	168	163	174	176	7
Calcium (DIS)	mg/l	26	26	40	46	43	42	44	45	2
Magnesium (DIS)	mg/l	26	26	13	16	15	14	15	16	1
Potassium (DIS)	mg/l	26	26	2	3	3	3	3	3	0
Sodium (DIS)	mg/l	26	26	4	5	5	5	5	5	0
Nitrate + Nitrite as n	mg/l	26	26	0.27	0.41	0.30	0.28	0.32	0.35	0.03
Aluminum (DIS)	mg/l	26	0	<0.009	--	--	--	--	--	--
Antimony (DIS)	mg/l	25	0	<0.0005	--	--	--	--	--	--
Antimony (TRC)	mg/l	1	0	<0.0005	--	--	--	--	--	--
Arsenic (DIS)	mg/l	25	25	0.003	0.004	0.004	0.003	0.004	0.004	0.000
Arsenic (TRC)	mg/l	1	1	0.003	0.003	--	--	--	--	--
Barium (DIS)	mg/l	25	25	0.102	0.121	0.111	0.108	0.113	0.120	0.005
Barium (TRC)	mg/l	1	1	0.112	0.112	--	--	--	--	--
Beryllium (DIS)	mg/l	25	0	<0.0008	--	--	--	--	--	--
Beryllium (TRC)	mg/l	1	0	<0.0008	--	--	--	--	--	--
Cadmium (DIS)	mg/l	25	0	<0.00003	--	--	--	--	--	--
Cadmium (TRC)	mg/l	1	0	<0.00003	--	--	--	--	--	--
Chromium (DIS)	mg/l	25	0	<0.01	--	--	--	--	--	--
Chromium (TRC)	mg/l	1	0	<0.01	--	--	--	--	--	--
Cobalt (DIS)	mg/l	25	0	<0.01	--	--	--	--	--	--
Cobalt (TRC)	mg/l	1	0	<0.01	--	--	--	--	--	--
Copper (DIS)	mg/l	25	1	0.015	0.015	--	--	--	--	--
Copper (TRC)	mg/l	1	0	<0.002	--	--	--	--	--	--
Iron (DIS)	mg/l	25	0	<0.02	--	--	--	--	--	--
Iron (TRC)	mg/l	1	0	<0.02	--	--	--	--	--	--
Lead (DIS)	mg/l	25	0	<0.0003	--	--	--	--	--	--
Lead (TRC)	mg/l	1	0	<0.0003	--	--	--	--	--	--
Manganese (DIS)	mg/l	25	0	<0.005	--	--	--	--	--	--
Manganese (TRC)	mg/l	1	0	<0.005	--	--	--	--	--	--
Mercury (DIS)	mg/l	25	1	<0.000005	0.0000071	--	--	--	--	--
Mercury (TRC)	mg/l	1	0	<0.000005	--	--	--	--	--	--
Molybdenum (DIS)	mg/l	25	0	<0.002	--	--	--	--	--	--
Molybdenum (TRC)	mg/l	1	0	<0.002	--	--	--	--	--	--
Nickel (DIS)	mg/l	25	0	<0.001	--	--	--	--	--	--
Nickel (TRC)	mg/l	1	0	<0.001	--	--	--	--	--	--
Selenium (DIS)	mg/l	25	22	<0.0002	0.0004	0.0003	0.0002	0.0003	0.0003	0.0001
Selenium (TRC)	mg/l	1	1	0.0002	0.0002	--	--	--	--	--
Silicon (DIS)	mg/l	1	1	15.1	15.1	--	--	--	--	--
Silver (DIS)	mg/l	25	0	<0.02	--	--	--	--	--	--
Silver (TRC)	mg/l	1	0	<0.02	--	--	--	--	--	--
Strontium (DIS)	mg/l	25	25	0.153	0.177	0.165	0.162	0.168	0.176	0.006
Strontium (TRC)	mg/l	1	1	0.168	0.168	--	--	--	--	--
Thallium (DIS)	mg/l	25	25	0.0009	0.0013	0.0010	0.0010	0.0010	0.0011	0.0001
Thallium (TRC)	mg/l	1	1	0.001	0.001	--	--	--	--	--
Uranium (DIS)	mg/l	25	0	<0.008	--	--	--	--	--	--
Uranium (TRC)	mg/l	1	0	<0.008	--	--	--	--	--	--
Zinc (DIS)	mg/l	25	0	<0.002	--	--	--	--	--	--
Zinc (TRC)	mg/l	1	0	<0.002	--	--	--	--	--	--

SP-8 - Statistical Analysis
Reporting Period - 5/2011 - 12/2016

Parameter	Units	No. Samples	No. Detects	Min.	Max.	Mean	25% PCTL	75% PCTL	95% PCTL	SD.
Flow	gallons per min	4	3	5	8.1	7.1	6.5	8.1	8.1	1.5
pH - Field	s.u.	5	5	7	7.91	7.44	7.34	7.50	7.83	0.29
Specific Conductance	umhos/cm	5	5	358	389	372	360	377	387	12
Water Temperature	Deg C	5	5	7.4	9.6	8.4	8.2	8.7	9.4	0.7
Dissolved Oxygen	mg/l	5	5	5.19	8.6	7.24	7.05	8.18	8.52	1.18

SP-9 - Statistical Analysis
Reporting Period - 5/2011 - 12/2016

Parameter	Units	No. Samples	No. Detects	Min.	Max.	Mean	25% PCTL	75% PCTL	95% PCTL	SD.
Flow	gallons per min	5	5	3.4	14.8	7.2	4.4	8.1	13.5	4.1
pH - Field	s.u.	5	5	7.56	8.87	8.04	7.75	8.14	8.72	0.46
Specific Conductance	umhos/cm	5	5	361	367	364	361	365	367	2
Water Temperature	Deg C	5	5	6.3	7.4	6.8	6.4	7.2	7.4	0.4
Dissolved Oxygen	mg/l	5	5	7.77	9.51	8.43	8.27	8.31	9.27	0.58

SP-10 - Statistical Analysis
Reporting Period - 5/2011 - 12/2016

Parameter	Units	No. Samples	No. Detects	Min.	Max.	Mean	25% PCTL	75% PCTL	95% PCTL	SD.
Flow	gallons per min	5	4	--	8.1	4.0	2.7	5.3	7.5	2.9
pH - Field	s.u.	5	5	7.36	8.06	7.67	7.40	7.80	8.01	0.26
Specific Conductance	umhos/cm	5	5	406	431	416	407	427	430	11
Water Temperature	Deg C	5	5	7.6	14.2	9.8	7.6	11.3	13.6	2.6
Dissolved Oxygen	mg/l	5	5	7.29	9.6	8.71	7.89	9.53	9.59	0.94

APPENDIX C

WELL LOGS



MONITORING WELL LITHOLOGIC AND COMPLETION LOG

JOB NO: 114-710301.300 WELL NO: MW-1A

PROJECT: Sheep Creek STATE: MT COUNTY: Meagher LOGGED BY: J Maus

LEGAL LOCATION: T 12N R 6E S 24 TRACT DDD DESCRIPTIVE LOCATION: Approximately 1000 ft N of County Rd 119 Intersection w/ Butte Creek Rd on west side of County Rd 119.

DATE STARTED: 6/29/2011 DATE COMPLETED: 6/29/2011 DRILLING CO/ DRILLER: O'Keefe - Larry Gagnon

DRILLING METHOD: Air Rotary BOREHOLE DIAM (IN): 6" DRILL FLUIDS USED: None

TOTAL DEPTH DRILLED: 38 TOTAL DEPTH CASSED: 34 INTERVAL PERFORATED FROM OR SCREENED (FT.): 25/34 DIAMETER: 2" CASING TYP: PVC

METHOD OF PERFORATION: Open Hole, Open Bottom, Saw Slotted, XX Factory 0.020 (size), Other. DURING WELL CONSTRUCTION WAS/WERE: Well Developed, Well Pumped, Water Samples Collected, Material Samples Collected. YES/NO table with X marks.

ANNULAR COMPLETION CHARACTERISTICS: WELL PROTECTOR: LENGTH: 5ft, DIAM: 6". SURFACE SEAL TYPE: Cement, Sand. BACKFILL MATERIAL: Bentonite. FILTER PACK TYPE: 10/20 Sand.

STATIC WATER LEVEL: 0 ft TPVC DATE: 6/30/2011 MEASURING POINT DESCRIPTION/ ELEVATION: TPVCN MEASURING POINT RELATIVE TO GROUND SURFACE (+/-) +2.0

REMARKS: Well just barely flowing out top of 2" pvc

Table with 3 columns: INTERVAL(FT), LITHOLOGIC DESCRIPTION, and REMARKS (BLOWS, HEADSPACE). Rows include lithologic descriptions like 'Red clay w/ 20% coarse gravel' and completion notes like 'Casing @ 35' bit @ 38' Pull bit up...'.



MONITORING WELL LITHOLOGIC AND COMPLETION LOG

JOB NO: 114-710301.300 WELL NO: MW-1B

PROJECT: Sheep Creek STATE: MT COUNTY: Meagher LOGGED BY: J Maus

LEGAL LOCATION: T 12N R 6E S 24 TRACT DDD DESCRIPTIVE LOCATION: Approximately 1000 ft N of County Rd 119 intersection with Butte Creek Rd on west side of County Rd 119

DATE STARTED: 6/30/2011 DATE COMPLETED: 6/30/2011 DRILLING CO/DRILLER: O'KEEFE - Larry Gagnon

DRILLING METHOD: Air Rotary BOREHOLE DIAM (IN): 6" DRILL FLUIDS USED: Water

TOTAL DEPTH DRILLED: 98' TOTAL DEPTH CASED: 98' INTERVAL PERFORATED FROM OR SCREENED (FT.): 88 98 DIAMETER: 2" CASING TYP: PVC

METHOD OF PERFORATION: Open Hole, Open Bottom, Saw Slotted, XX Factory .020 (size), Other. DURING WELL CONSTRUCTION WAS/WERE: Well Developed, Well Pumped, Water Samples Collected, Material Samples Collected. YES/NO table with Bailer.

ANNULAR COMPLETION CHARACTERISTICS

WELL PROTECTOR: LENGTH: 5' DIAM: 6" SURFACE SEAL TYPE: Cement FROM: 0 TO: 2 BACKFILL MATERIAL: Grout/Bent. FROM: 2 TO: 86 FILTER PACK TYPE: 10/20 Sand FROM: 86 TO: 98

STATIC WATER LEVEL: 21.73 DATE: 6/30/2011 MEASURING POINT DESCRIPTION/ELEVATION: TPVCN MEASURING POINT RELATIVE TO GROUND SURFACE (+/-) +2.0

REMARKS:

Table with 3 columns: INTERVAL(FT), LITHOLOGIC DESCRIPTION, REMARKS (BLOWS, HEADSPACE). Rows include lithologic descriptions like 'Red clay w/ 20% coarse gravel, 30% fine-coarse sand moist' and 'Weathered black shale'.

Client: Tintina Resources
 Project: Black Butte Copper Project
 County: Meagher State: MT
 Property Owner: Bar Z Ranch Inc
 Legal Description: NE, SW, NE S25, T12N, R06E
 Location Description: Downgradient of proposed adit, near Coon Creek
 Recorded By: Doug Parker
 Drilling Company: H&L Drilling
 Driller: Dan
 Drilling Method: Air Rotary
 Drilling Fluids Used: Air/Water
 Purpose of Hole: Install Monitor Well
 Target Aquifer: Overburden
 Hole Diameter (in): 6
 Total Depth Drilled (ft): 62

WELL COMPLETION	Y/N	DESCRIPTION	INTERVAL
Well Installed?	Y	2-inch, flush threaded, Sch 40, PVC	+2 to 62
Surface Casing Used?	Y	6-inch, steel casing	+2 to 20
Screen/Perforations?	Y	0.020-inch slot, Sch 40 PVC	52-62
Sand Pack?	Y	10/20 Silica Sand	47-62
Annular Seal?	Y	Bentonite Grout	2-47
Surface Seal?	Y	Portland Cement	+0.5-2

DEVELOPMENT/SAMPLING	
Well Developed?	Y Air for 30 min
Water Samples Taken?	Y Commons, Nutrients, Metals
Boring Samples Taken?	N

Northing: 5180331.93 Easting: 506598.18
 Static Water Level Below MP: 42.12 Surface Casing Height (ft):
 Date: 11/24/14 Riser Height (ft): 2
 MP Description: Top of PVC Ground Surface Elevation (ft): 5745.31
 MP Height Above or Below Ground (ft): 1.6 MP Elevation (ft): 5745.42

Remarks:

WELL CONSTRUCTION

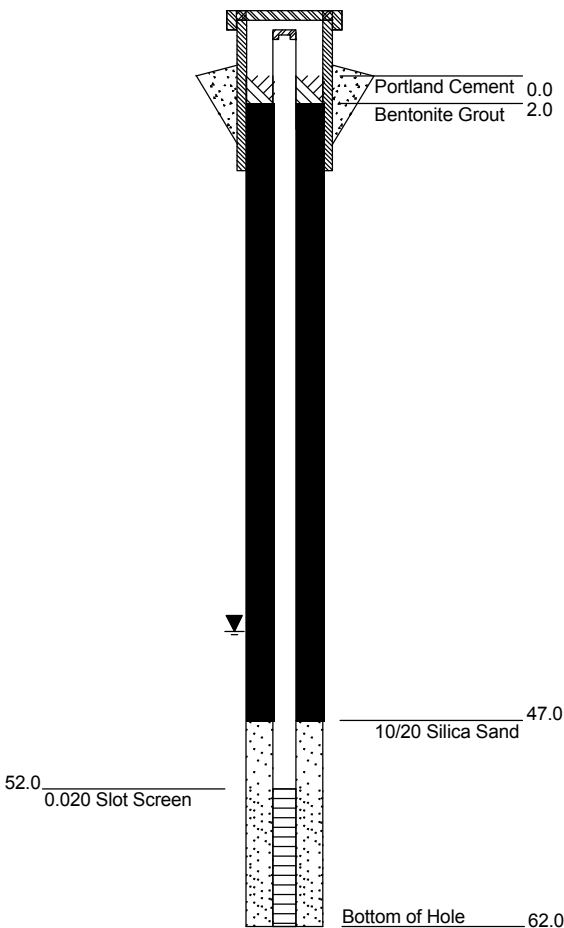

SAMPLE NOTES

GRAPHICS

GEOLOGICAL DESCRIPTION

0.0 - 10.0' **Sandy Clay**
 Reddish brown, non plastic clay with 30% fine to coarse sand and 10% fine gravel clasts, moist.

10.0 - 20.0' **Silty Sand**
 Tan, moderately sorted fine grained sand with 20% silt. Dry

20.0 - 38.0' **Sandy Clay**
 Orange, non plastic clay with 15% fine to coarse sand and 10% fine subangular to subrounded gravel. moist

38.0 - 62.0' **Gravelly Clay**
 Orange, non-plastic clay with varying amounts of fine gravel (10% to 30%), some coarse jasper clast. making 5 gpm at 62 feet.

Client: Tintina Resources
 Project: Black Butte Copper Project
 County: Meagher State: MT
 Property Owner: Bar Z Ranch Inc
 Legal Description: NE, SW, NE S25, T12N, R06E
 Location Description: Downgradient of proposed adit, near Coon Creek
 Recorded By: Doug Parker
 Drilling Company: H&L Drilling
 Driller: Dan
 Drilling Method: Air Rotary
 Drilling Fluids Used: Air/Water
 Purpose of Hole: Install Monitor Well
 Target Aquifer: Bedrock
 Hole Diameter (in): 6
 Total Depth Drilled (ft): 80

WELL COMPLETION	Y/N	DESCRIPTION	INTERVAL
Well Installed?	Y	2-inch, flush threaded, Sch 40, PVC	+2 to 80
Surface Casing Used?	Y	6-inch, steel casing	+2 to 20
Screen/Perforations?	Y	0.020-inch slot, Sch 40 PVC	70-80
Sand Pack?	Y	10/20 Silica Sand	65-80
Annular Seal?	Y	Bentonite Grout	2-65
Surface Seal?	Y	Portland Cement	+0.5-2

DEVELOPMENT/SAMPLING			
Well Developed?	Y	Air for 30 min	
Water Samples Taken?	Y	Commons, Nutrients, Metals	
Boring Samples Taken?	N		

Northing: 5180328.73 Easting: 506596.96
 Static Water Level Below MP: 41.94 Surface Casing Height (ft):
 Date: 11/24/14 Riser Height (ft): 2
 MP Description: Top of PVC Ground Surface Elevation (ft): 5745.53
 MP Height Above or Below Ground (ft): 2.1 MP Elevation (ft): 5745.04

Remarks:

WELL CONSTRUCTION

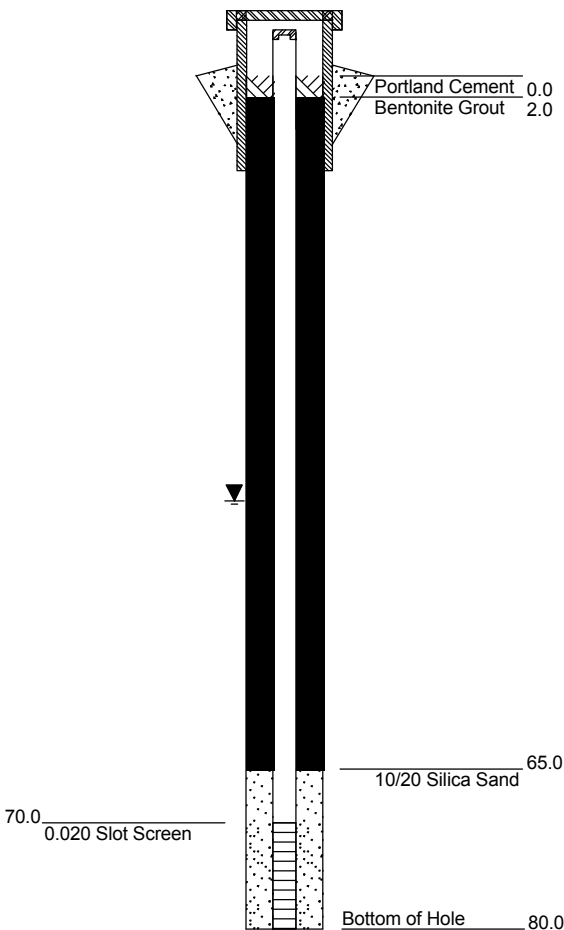

SAMPLE NOTES

GRAPHICS

GEOLOGICAL DESCRIPTION

0.0 - 10.0' **Sandy Clay**
 Reddish brown, non plastic clay with 30% fine to coarse sand and 10% fine gravel clasts, moist.

10.0 - 20.0' **Silty Sand**
 Tan, moderately sorted fine grained sand with 20% silt. Dry

20.0 - 38.0' **Sandy Clay**
 Orange, non plastic clay with 15% fine to coarse sand and 10% fine subangular to subrounded gravel. moist

38.0 - 62.0' **Gravelly Clay**
 Orange, non-plastic clay with varying amounts of fine gravel (10% to 30%), some coarse jasper clast. making 5 gpm at 62 feet.

62.0 - 80.0' **Shale**
 Dark gray to black shale with minor weathering. Hard drilling. making 5-6 gpm at 80 feet

Client: Tintina Resources
 Project: Black Butte Copper Project
 County: Meagher State: MT
 Property Owner: Bar Z Ranch Inc
 Legal Description: NW, NW, NE S25, T12N, R06E
 Location Description: South of proposed adit, near Dry Creek
 Recorded By: Doug Parker/ Greg Bryce
 Drilling Company: H&L Drilling
 Driller: Dan
 Drilling Method: Air Rotary
 Drilling Fluids Used: Air/Water
 Purpose of Hole: Install Monitor Well
 Target Aquifer: Bedrock - Ore
 Hole Diameter (in): 6
 Total Depth Drilled (ft): 305

WELL COMPLETION	Y/N	DESCRIPTION	INTERVAL
Well Installed?	Y	2-inch, flush threaded, Sch 40, PVC	+2 to 305
Surface Casing Used?	Y	6-inch, steel casing	+2 to 78
Screen/Perforations?	Y	0.020-inch slot, Sch 40 PVC	285-305
Sand Pack?	Y	10/20 Silica Sand	280-305
Annular Seal?	Y	Bentonite Grout	2-280
Surface Seal?	Y	Portland Cement	+0.5-2

DEVELOPMENT/SAMPLING			
Well Developed?	Y	Air for 45 min	
Water Samples Taken?	Y	Commons, Nutrients, Metals	
Boring Samples Taken?	N		

Northing: 5180740.22	Easting: 506484.07
Static Water Level Below MP: 45.96	Surface Casing Height (ft):
Date: 11/24/14	Riser Height (ft): 2
MP Description: Top of PVC	Ground Surface Elevation (ft): 5762.17
MP Height Above or Below Ground (ft): 2.1	MP Elevation (ft): 5762.17

Remarks:

WELL CONSTRUCTION

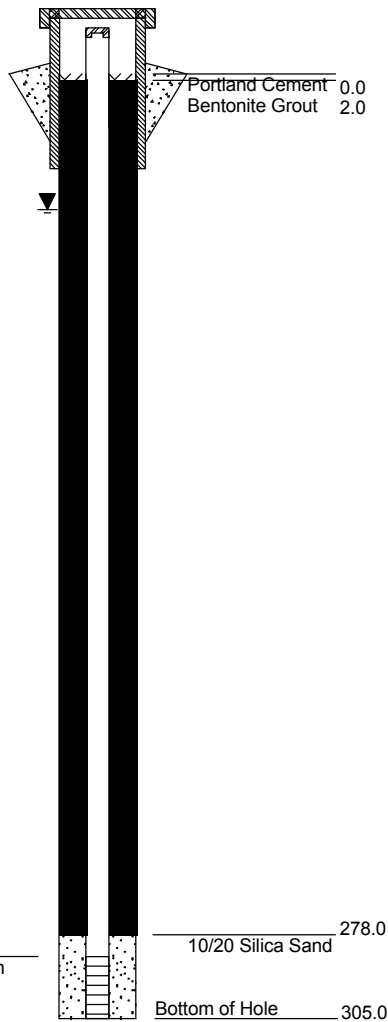

SAMPLE NOTES

GRAPHICS

GEOLOGICAL DESCRIPTION

0.0 - 10.0' **Clayey Sand**
 Brown/Orange poorly sorted fine to coarse sand with 20% clay and trace gravel.

10.0 - 68.0' **Siltstone**
 Orange/Red/Tan highly weathered siltstone. Start making water at 55 feet (10-15 gpm)

68.0 - 80.0' **Shale**
 Dark gray/black soft shale with clay

80.0 - 100.0' **Shale**
 Dark gray/black soft shale with clay, with minor hard gray layers

100.0 - 200.0' **Shale**
 Black to dark gray silick shale, hard drilling with minor weathering/fractures at 140 to 150'. Increasing water with depth: ~1 gpm 100-175', 5 gpm @ 175', 10 gpm @ 200'

200.0 - 260.0' **Shale**
 Black to dark gray silick shale with traces of very fine pyrite. Increasing water with depth: 20 gpm @ 205', 35 gpm @ 210'

260.0 - 285.0' **Shale with massive Sulfide**
 Dark gray/black shale and equal parts pyrite; pyrite sheen on water. Making 50 gpm at 285'

285.0 - 305.0' **Massive Sulfide with shale**
 Coarse pyrite (3/8") with 30% shale; 2-5% calcite chips. No increase in water.

Client: Tintina Resources
 Project: Black Butte Copper Project
 County: Meagher State: MT
 Property Owner: Bar Z Ranch Inc
 Legal Description: SW, SW, SW S19, T12N, R06E
 Location Description: Stawberry Butte Hayfield

Recorded By: Bill Thompson/ Brad Maddock
 Drilling Company: H&L Drilling
 Driller: Dan
 Drilling Method: Air Rotary
 Drilling Fluids Used: Air/Water
 Purpose of Hole: Install Monitor Well
 Target Aquifer: Shallow Bedrock
 Hole Diameter (in): 6
 Total Depth Drilled (ft): 23

WELL COMPLETION	Y/N	DESCRIPTION	INTERVAL
Well Installed?	Y	2-inch, flush threaded, Sch 40, PVC	+2 to 23
Surface Casing Used?	Y	6-inch, steel casing	+2 to 23
Screen/Perforations?	Y	0.020-inch slot, Sch 40 PVC	14-23
Sand Pack?	Y	10/20 Silica Sand	11-23
Annular Seal?	Y	Bentonite Chips	0-23
Surface Seal?	Y	Portland Cement	0-1

DEVELOPMENT/SAMPLING		
Well Developed?	Y	Air for 1 hour
Water Samples Taken?	Y	Commons, Nutrients, Metals
Boring Samples Taken?	N	

Northing: 5180855.43 Easting: 507201.47
 Static Water Level Below MP: 4.90 Surface Casing Height (ft):
 Date: 11/24/14 Riser Height (ft): 2
 MP Description: Top of PVC Ground Surface Elevation (ft): 5610.38
 MP Height Above or Below Ground (ft): 2 MP Elevation (ft): 5611.96

Remarks:

WELL CONSTRUCTION

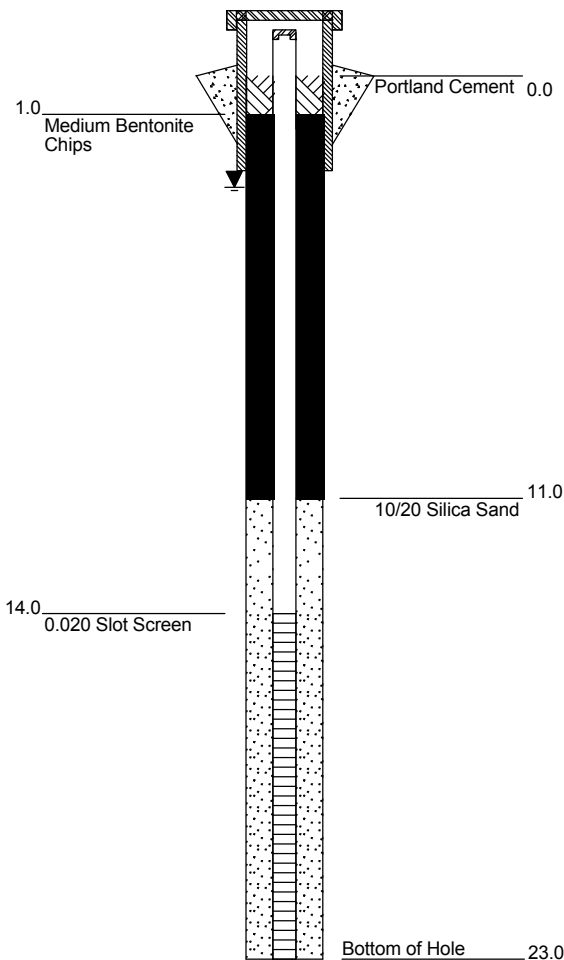

SAMPLE NOTES

GRAPHICS

GEOLOGICAL DESCRIPTION

0.0 - 1.0'	TOPSOIL Brown top soil.
1.0 - 5.0'	SANDY CLAYEY GRAVEL Brown sandy clayey gravel.
5.0 - 10.0'	SANDY CLAYEY GRAVEL Brown sandy gravel and clay. Gravel is mixed metamorphic sedimentary rocks, fine to medium sized, rounded to subangular. Wet.
10.0 - 20.0'	SANDY GRAVEL Light brown sand and gravel with some silt to clay. Wet.
20.0 - 23.0'	GRAVELY SAND Increasing gravel. Very wet. At 20' hole producing ~30 gpm.

Client: Tintina Resources
 Project: Black Butte Copper Project
 County: Meagher State: MT
 Property Owner: Bar Z Ranch Inc
 Legal Description: SW, SW, SW S19, T12N, R06E
 Location Description: Stawberry Butte Hayfield

Recorded By: Bill Thompson/ Brad Maddock
 Drilling Company: H&L Drilling
 Driller: Dan
 Drilling Method: Air Rotary
 Drilling Fluids Used: Air/Water
 Purpose of Hole: Install Monitor Well
 Target Aquifer: Shallow Bedrock
 Hole Diameter (in): 6
 Total Depth Drilled (ft): 59

WELL COMPLETION	Y/N	DESCRIPTION	INTERVAL
Well Installed?	Y	2-inch, flush threaded, Sch 40, PVC	+2 to 59
Surface Casing Used?	Y	6-inch, steel casing	+2 to 59
Screen/Perforations?	Y	0.020-inch slot, Sch 40 PVC	39-59
Sand Pack?	Y	10/20 Silica Sand	37-59
Annular Seal?	Y	Bentonite Chips	0-37
Surface Seal?	Y	Portland Cement	0-1
DEVELOPMENT/SAMPLING			
Well Developed?	Y	Air for 15 min	
Water Samples Taken?	Y	Commons, Nutrients, Metals	
Boring Samples Taken?	N		
Northing: 5180858.49		Easting: 507200.12	
Static Water Level Below MP: 4.49		Surface Casing Height (ft):	
Date: 11/24/14		Riser Height (ft): 2	
MP Description: Top of PVC		Ground Surface Elevation (ft): 5610.28	
MP Height Above or Below Ground (ft): 2		MP Elevation (ft): 5611.45	

Remarks:

WELL CONSTRUCTION

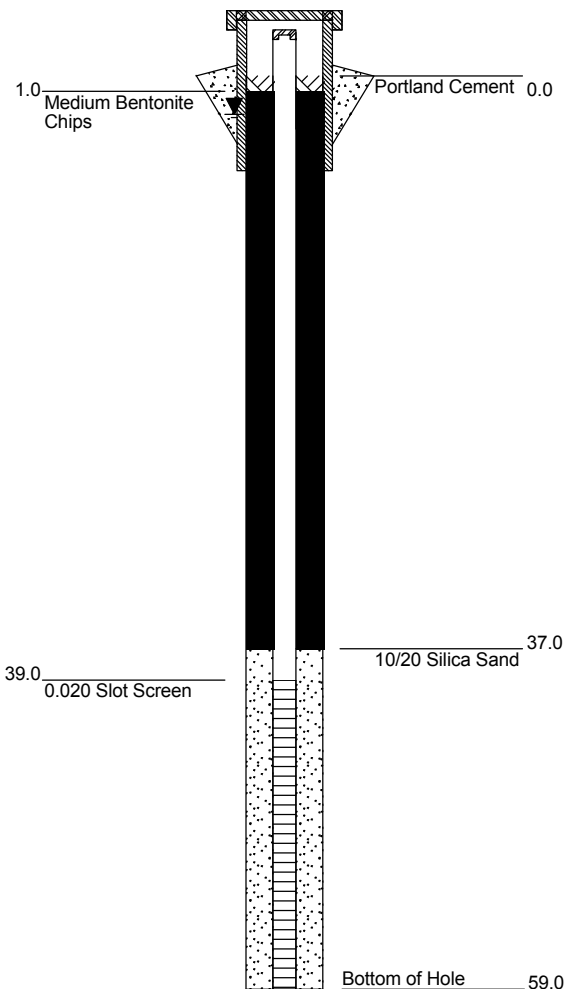

SAMPLE NOTES

GRAPHICS

GEOLOGICAL DESCRIPTION

0.0 - 1.0' **TOPSOIL**
Brown Top Soil.

1.0 - 25.0' **SANDY CLAYEY GRAVEL**
Brown sandy clayey gravel. Gravel is fine to medium subrounded to angular. Fewer fines at 20'. Wet at 5'.

25.0 - 27.0' **CLAYEY GRAVEL**
Sharp transition to orange/ brown clayey gravel.

27.0 - 55.0' **SHALE**
Contact with dark grey shale (bedrock) no evidence of sulfide. At 40' hole is producing < .5 gpm water.

55.0 - 59.0' **SHALE**
Dark grey shale with thin interval of brown shale. Increased flow. Producing ~6 gpm of discharge.

Client: Tintina Resources
 Project: Black Butte Copper Project
 County: Meagher State: MT
 Property Owner: Holmstrom Short Ranch LLC
 Legal Description: NE, SE, SW S30, T12N, R07E
 Location Description: LAD Area, paired well

Recorded By: Larry Johnson
 Drilling Company: National
 Driller: Jake Jesson
 Drilling Method: Dual Air Rotary
 Drilling Fluids Used: Air
 Purpose of Hole: Install Monitor Well
 Target Aquifer: First Water
 Hole Diameter (in): 8
 Total Depth Drilled (ft): 20

WELL COMPLETION	Y/N	DESCRIPTION	INTERVAL
Well Installed?	Y	2-inch, flush threaded, Sch 40, PVC	+1.8 to 20
Surface Casing Used?	Y	8-inch, steel casing	+1.9 to 3.1
Screen/Perforations?	Y	0.020-inch slot, Sch 40 PVC	5 to 15
Sand Pack?	Y	10/20 silica sand	3 to 15
Annular Seal?	Y	Bentonite Chips	1-3
Surface Seal?	Y	Portland cement	0-1
DEVELOPMENT/SAMPLING			
Well Developed?	Y	Surged/bailed	
Water Samples Taken?	Y	Commons, Nutrients, Metals	
Boring Samples Taken?	Y	Every 5 feet	chips
Northing: 5179492.85		Easting: 507809.18	
Static Water Level Below MP: 9.28		Surface Casing Height (ft): 1.9	
Date: 11/24/14		Riser Height (ft): 1.8	
MP Description: Top of PVC		Ground Surface Elevation (ft): 5680.08	
MP Height Above or Below Ground (ft): 1.8		MP Elevation (ft): 5681.87	

Remarks: Well sited in LAD area; shallow well of pair

WELL CONSTRUCTION

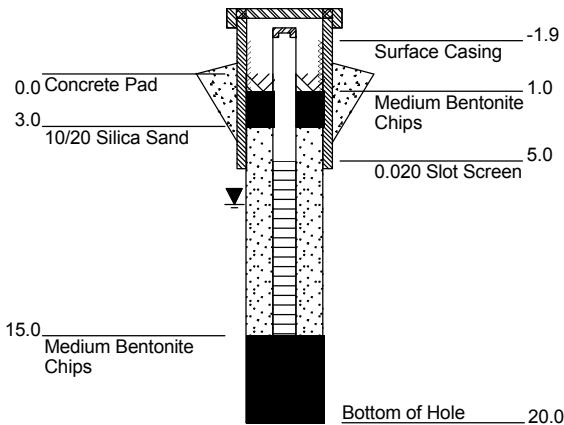

SAMPLE NOTES

GRAPHICS

GEOLOGICAL DESCRIPTION

0.0 - 0.5' **TOPSOIL**
Dark brown soil

0.5 - 20.0' **Dolostone**
Tan to gray dolostone with tan clay on surface.

Trace water at 10 feet. Conducted flow test, water dried up rapidly

Trace water at 15 feet.

Trace water at 20', dried up immediately during flow test.

Client: Tintina Resources
 Project: Black Butte Copper Project
 County: Meagher State: MT
 Property Owner: Holmstrom Short Ranch LLC
 Legal Description: NE, SE, SW S30, T12N, R07E
 Location Description: LAD Area, paired well

Recorded By: Larry Johnson
 Drilling Company: National
 Driller: Jake Jesson
 Drilling Method: Dual Air Rotary
 Drilling Fluids Used: Air
 Purpose of Hole: Install Monitor Well
 Target Aquifer: First Water
 Hole Diameter (in): 8
 Total Depth Drilled (ft): 50

WELL COMPLETION	Y/N	DESCRIPTION	INTERVAL
Well Installed?	Y	2-inch, flush threaded, Sch 40, PVC	+1.9 to 50
Surface Casing Used?	Y	8-inch, steel casing	+2 to 3
Screen/Perforations?	Y	0.020-inch slot, Sch 40 PVC	40 to 50
Sand Pack?	Y	10/20 silica sand	37 to 50
Annular Seal?	Y	Bentonite Chips	1-37
Surface Seal?	Y	Portland cement	0-1

DEVELOPMENT/SAMPLING			
Well Developed?	Y	Surged/bailed	
Water Samples Taken?	Y	Commons, Nutrients, Metals	
Boring Samples Taken?	Y	Every 5 feet	chips

Northing: 5179490.71 Easting: 507792.76
 Static Water Level Below MP: 11.96 Surface Casing Height (ft): 2
 Date: 11/24/14 Riser Height (ft): 1.9
 MP Description: Top of PVC Ground Surface Elevation (ft): 5683.41
 MP Height Above or Below Ground (ft): 1.9 MP Elevation (ft): 5685.31

Remarks: Well sited in LAD area; deep well of pair

WELL CONSTRUCTION

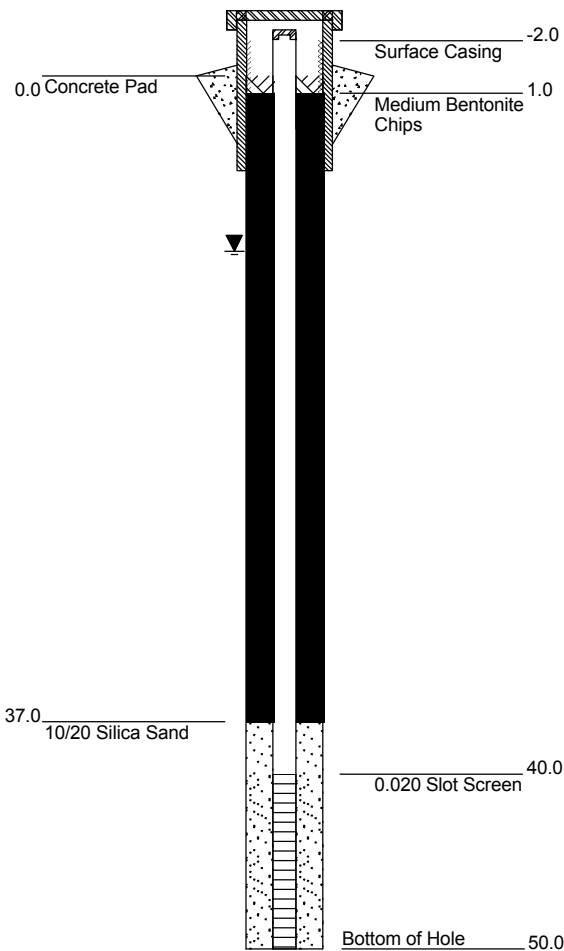

SAMPLE NOTES

GRAPHICS

GEOLOGICAL DESCRIPTION

0.0 - 0.5' **TOPSOIL**
Dark brown soil

0.5 - 40.0' **Dolostone**
Tan to gray dolostone with tan clay on surface.

Trace water at 10 feet.

Trace water at 20 feet. Borehole dried up rapidly during flow test.

Increased clay at 30 feet, wet

40.0 - 50.0' **Dolostone**
Gray dolostone. Making 2 gpm at 40 feet.

Making 2 gpm at bottom of hole.

Client: Tintina Resources
 Project: Black Butte Copper Project
 County: Meagher State: MT
 Property Owner: Holmstrom Short Ranch LLC
 Legal Description: NE, SW, SW S30, T12N, R07E
 Location Description: LAD AREA

Recorded By: Larry Johnson
 Drilling Company: National
 Driller: Jake Jesson
 Drilling Method: Dual Air Rotary
 Drilling Fluids Used: Air
 Purpose of Hole: Install Monitor Well
 Target Aquifer: First Water
 Hole Diameter (in): 8
 Total Depth Drilled (ft): 50

WELL COMPLETION	Y/N	DESCRIPTION	INTERVAL
Well Installed?	Y	2-inch, flush threaded, Sch 40, PVC	+2 to 50
Surface Casing Used?	Y	8-inch, steel casing	+2.1 to 2.9
Screen/Perforations?	Y	0.020-inch slot, Sch 40 PVC	40 - 50
Sand Pack?	Y	10/20 silica sand	37 - 50
Annular Seal?	Y	Bentonite Chips	1-37
Surface Seal?	Y	Portland cement	0-1
DEVELOPMENT/SAMPLING			
Well Developed?	Y	Surged/bailed	
Water Samples Taken?	Y	Commons, Nutrients, Metals	
Boring Samples Taken?	Y	Every 5 feet	chips
Northing: 5179500.71		Easting: 507451.7	
Static Water Level Below MP: 31.91		Surface Casing Height (ft): 2.1	
Date: 11/24/14		Riser Height (ft): 2	
MP Description: Top of PVC		Ground Surface Elevation (ft): 5747.48	
MP Height Above or Below Ground (ft): 2		MP Elevation (ft): 5749.46	

Remarks: Well sited in LAD area

WELL CONSTRUCTION

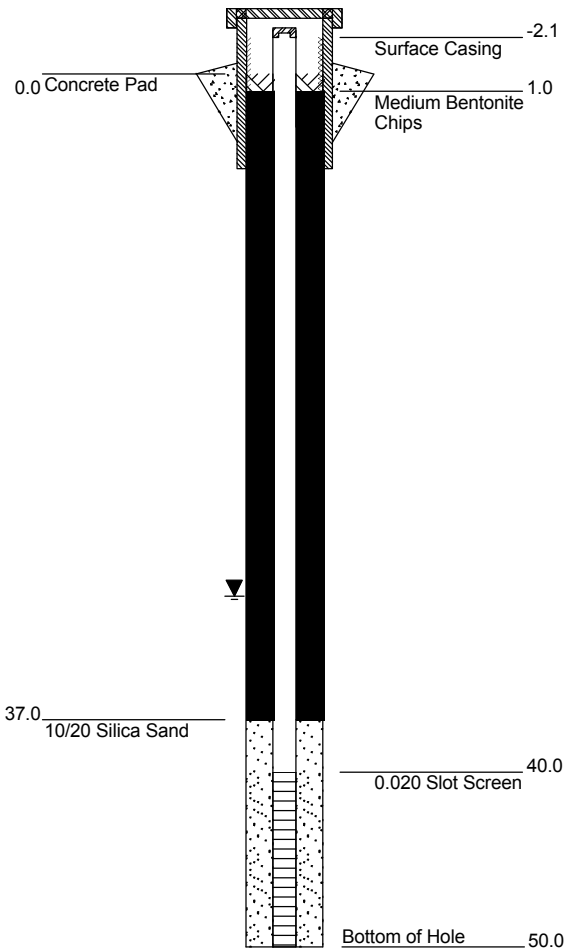

SAMPLE NOTES

GRAPHICS

GEOLOGICAL DESCRIPTION

0.0 - 0.5'	TOPSOIL
0.5 - 20.0'	Dolostone Gray Dolostone, dry.
20.0 - 50.0'	Dolostone Gray Dolostone with intermittent broken zones.
	Broken zone at 28 feet, dry
	Tan shale from 29 to 30 feet, dry.
	Incountered water between 45 and 50 feet. Making 1-2 gpm.

Client: Tintina Resources
 Project: Black Butte Copper Project
 County: Meagher State: MT
 Property Owner: Bar Z Ranch Inc
 Legal Description: SE, SE, SE S25, T12N, R06E
 Location Description: LAD AREA

Recorded By: Larry Johnson
 Drilling Company: National
 Driller: Jake Jesson/Jeff Ferguson
 Drilling Method: Dual Air Rotary
 Drilling Fluids Used: Air
 Purpose of Hole: Install Monitor Well
 Target Aquifer: First Water
 Hole Diameter (in): 8
 Total Depth Drilled (ft): 80

WELL COMPLETION	Y/N	DESCRIPTION	INTERVAL
Well Installed?	Y	2-inch, flush threaded, Sch 40, PVC	+1.8 to 80
Surface Casing Used?	Y	8-inch steel casing	+1.9 to 3.1
Screen/Perforations?	Y	0.020-inch slot, Sch 40 PVC	70 - 80
Sand Pack?	Y	10/20 silica sand	67 - 80
Annular Seal?	Y	Bentonite Chips	1-67
Surface Seal?	Y	Portland Cement	0-1
DEVELOPMENT/SAMPLING			
Well Developed?	Y	Surged/bailed	
Water Samples Taken?	Y	Commons, Nutrients, Metals	
Boring Samples Taken?	Y	Every 5 feet	chips
Northing: 5179398.31		Easting: 507036	
Static Water Level Below MP: 30.45		Surface Casing Height (ft): 1.9	
Date: 11/24/14		Riser Height (ft): 1.8	
MP Description: Top of PVC		Ground Surface Elevation (ft): 5809.10	
MP Height Above or Below Ground (ft): 1.8		MP Elevation (ft): 5810.93	

Remarks: Well sited in LAD area

WELL CONSTRUCTION

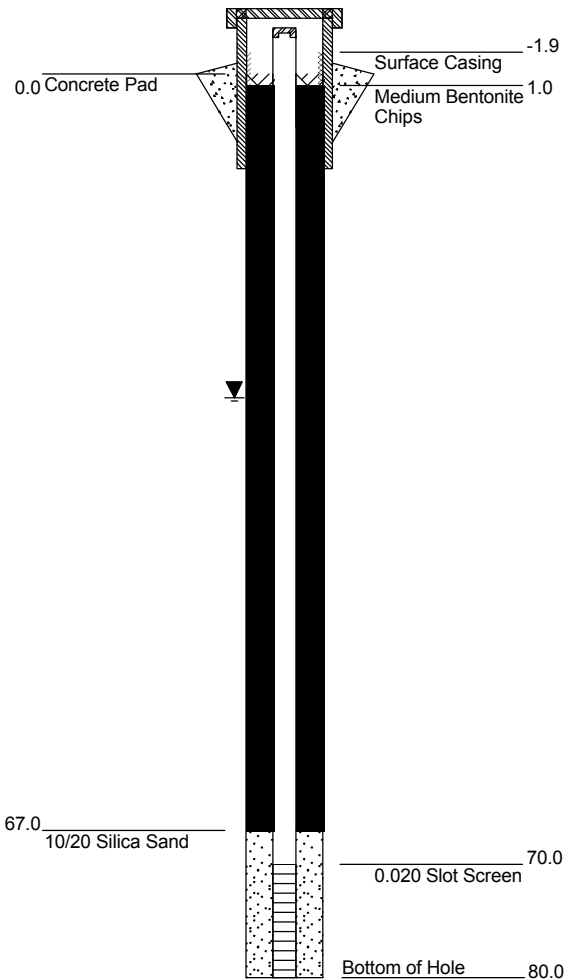

SAMPLE NOTES

GRAPHICS

GEOLOGICAL DESCRIPTION

0.0 - 0.5' **TOPSOIL**

0.5 - 35.0' **Dolostone**
Gray Dolostone, minor fracturing; dry.

Minor water encountered at 35 feet, dried up rapidly no water returning to borehole after 30 mins of letting sit.

35.0 - 80.0' **Dolostone**
Gray Dolostone.

Incounter water between 65 to 70 feet. Making 1-2 gpm at 80 feet.

Client: Tintina Resources
 Project: Black Butte Copper Project
 County: Meagher State: MT
 Property Owner: Bar Z Ranch Inc
 Legal Description: NW, NW, NE S25, T12N, R06E
 Location Description: North of Dry Creek near center of UCZ
 Recorded By: Ashton Montrone
 Drilling Company: H&L Drilling
 Driller: Derrick Toney
 Drilling Method: Air Rotary
 Drilling Fluids Used: Air, Water, Foam
 Purpose of Hole: Install Monitor Well
 Target Aquifer: Bedrock
 Hole Diameter (in): 8
 Total Depth Drilled (ft): 143.7

WELL COMPLETION	Y/N	DESCRIPTION	INTERVAL
Well Installed?	Y	2-inch, flush threaded, Sch 40, PVC	+1.5 to 130
Surface Casing Used?	Y	6-inch, steel casing	+2.0 to 58
Screen/Perforations?	Y	0.020-inch slot, Sch 40 PVC	108-128
Sand Pack?	Y	10/20 Silica Sand	98 to 143.7
Annular Seal?	Y	Bentonite Grout	0-98
Surface Seal?	Y	Portland Cement	0-1
DEVELOPMENT/SAMPLING			
Well Developed?	Y	Air for 1.5 hours	
Water Samples Taken?	Y	No sample taken	
Boring Samples Taken?	Y	Every 10 feet	chips
Northing: 5180725.46		Easting: 506592.96	
Static Water Level Below MP: 49.68		Surface Casing Height (ft):	
Date: 11/24/14		Riser Height (ft): 1.5	
MP Description: Top of PVC		Ground Surface Elevation (ft): 5743.59	
MP Height Above or Below Ground (ft): 2		MP Elevation (ft): 5745.8	

Remarks: Produced no water during development

WELL CONSTRUCTION

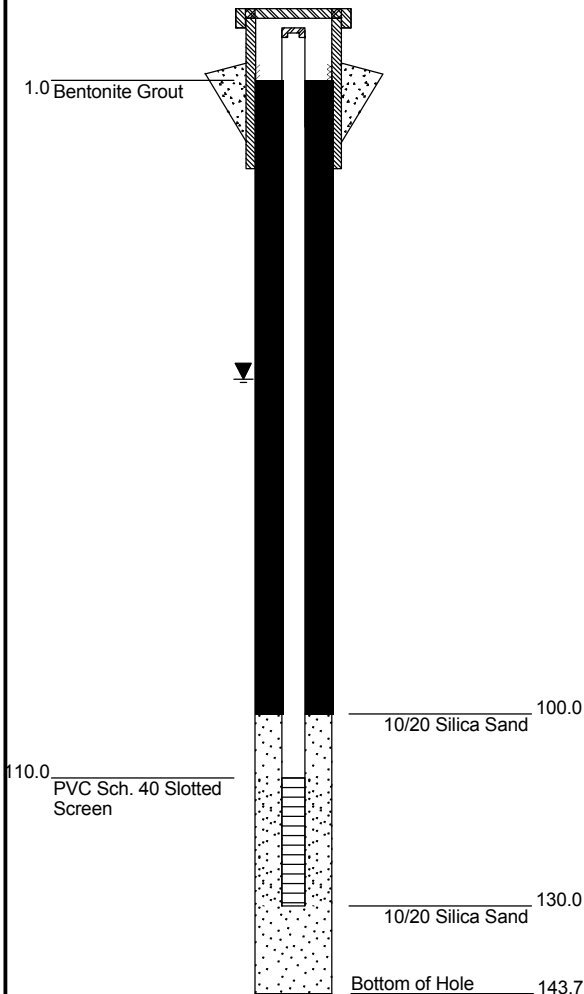

SAMPLE NOTES

GRAPHICS

GEOLOGICAL DESCRIPTION

1.0 - 20.0'	Sandy clay Moderately oxidized medium to coarse sub-rounded sandy clay. Siltstones (20%-40%) and gossan (~5%) present. No water.
20.0 - 40.0'	Sandy clay Red and cream colored angular/sub-angular siltstones (50%) in a moderately oxidized sandy clay matrix. No water.
40.0 - 60.0'	Siltstone 50% highly weathered sub-rounded/sub-angular black shale with >75% oxidized facies, 20% red sub-rounded siltstones, in highly oxidized clay matrix with angular/sub-angular shale origin medium sand fragments. No water.
60.0 - 90.0'	Shale 95% dark gray angular/sub-angular shale, highly weathered and oxidized on 50% of facies. ~5% siltstones angular/sub-angular. No water.
90.0 - 130.0'	Shale Dark gray angular/sub-angular shale. Small amounts of pyrite and chalcocopyrite present. 2-3 gpm.
130.0 - 140.0'	Shale 50% dark gray sub angular shale, 50% light gray sub-angular shale. Small quartzite veins (~5%) apparent. Considerable amounts of massive and disseminated sulfides present. 8 gpm

Client: Tintina Resources
 Project: Black Butte Copper Project
 County: Meagher State: MT
 Property Owner: Bar Z Ranch Inc
 Legal Description: SE, SW, SW S25, T12N, R06E
 Location Description: North end of CTF toe
 Recorded By: Ashton Montrone
 Drilling Company: Enviromental West
 Driller: Randy
 Drilling Method: Odex
 Drilling Fluids Used: Air
 Purpose of Hole: Install Monitor Well
 Target Aquifer: CTF Toe
 Hole Diameter (in): 6
 Total Depth Drilled (ft): 90

WELL COMPLETION	Y/N	DESCRIPTION	INTERVAL
Well Installed?	Y	2-inch, flush threaded, Sch 40, PVC	+2 to 90
Surface Casing Used?	Y	6-inch, steel casing	+2 to 3
Screen/Perforations?	Y	0.020-inch slot, Sch 40 PVC	70-90
Sand Pack?	Y	10/20 Silica Sand	67-90
Annular Seal?	Y	Bentonite Chips	0.5-67
Surface Seal?	Y	Portland Cement	+0.5-0.5
DEVELOPMENT/SAMPLING			
Well Developed?	N		
Water Samples Taken?	Y	Commons, Nutrients, Metals	
Boring Samples Taken?	Y	chips	Every 5 feet
Northing: 5179215.045		Easting: 506578.567	
Static Water Level Below MP: 79.21		Surface Casing Height (ft): 2	
Date: 3/28/16		Riser Height (ft): 2	
MP Description: Top of PVC		Ground Surface Elevation (ft): 5882.78	
MP Height Above or Below Ground (ft): 2		MP Elevation (ft): 5886.11	

Remarks: Borehole was dry during drilling; water level at 91.4' below measuring point (TD 92.5), water level up to 79.21 ten days after well completion. Insufficient water to develop.

WELL CONSTRUCTION

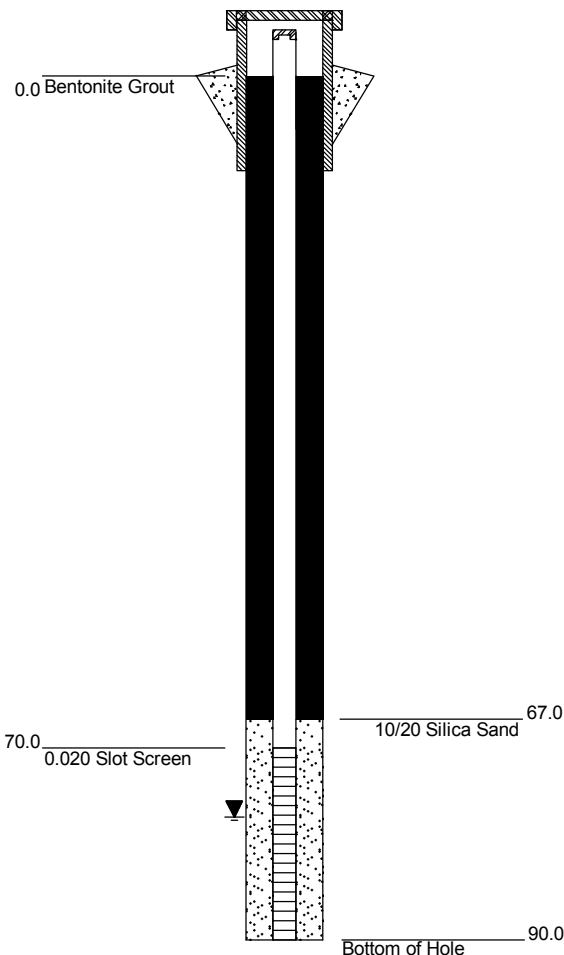

SAMPLE NOTES

GRAPHICS

GEOLOGICAL DESCRIPTION

0.0 - 30.0' **Granodiorite**
 Granodiorite, grey and tan with mafic minerals, clay seam from 4-5' and 19.5-20', highly weathered near surface with less weahtering with depth. Dry

30.0 - 90.0' **Granodiorite**
 Granodiorite, grey and tan, redish staining 45 to 55 feet, drilling hard. Dry during drilling.

Client: Tintina Resources
 Project: Black Butte Copper Project
 County: Meagher State: MT
 Property Owner: Bar Z Ranch Inc
 Legal Description: NE, NW, NW S26, T12N, R06E
 Location Description: Middle of CTF toe
 Recorded By: Ashton Montrone
 Drilling Company: Enviromental West
 Driller: Randy
 Drilling Method: Odex
 Drilling Fluids Used: Air
 Purpose of Hole: Install Monitor Well
 Target Aquifer: CTF Toe
 Hole Diameter (in): 6
 Total Depth Drilled (ft): 70

WELL COMPLETION	Y/N	DESCRIPTION	INTERVAL
Well Installed?	Y	2-inch, flush threaded, Sch 40, PVC	+2 to 70
Surface Casing Used?	Y	6-inch, steel casing	+2 to 3
Screen/Perforations?	Y	0.020-inch slot, Sch 40 PVC	50-70
Sand Pack?	Y	10/20 Silica Sand	46-70
Annular Seal?	Y	Bentonite Chips	0.5-46
Surface Seal?	Y	Portland Cement	+0.5-0.5
DEVELOPMENT/SAMPLING			
Well Developed?	Y	surge and pump	
Water Samples Taken?	Y	Commons, Nutrients, Metals	
Boring Samples Taken?	Y	chips	Every 5 feet
Northing: 5179117.473		Easting: 506464.724	
Static Water Level Below MP: 34.70		Surface Casing Height (ft): 2	
Date: 3/28/16		Riser Height (ft): 2	
MP Description: Top of PVC		Ground Surface Elevation (ft): 5854.74	
MP Height Above or Below Ground (ft): 2		MP Elevation (ft): 5857.86	

Remarks:

WELL CONSTRUCTION

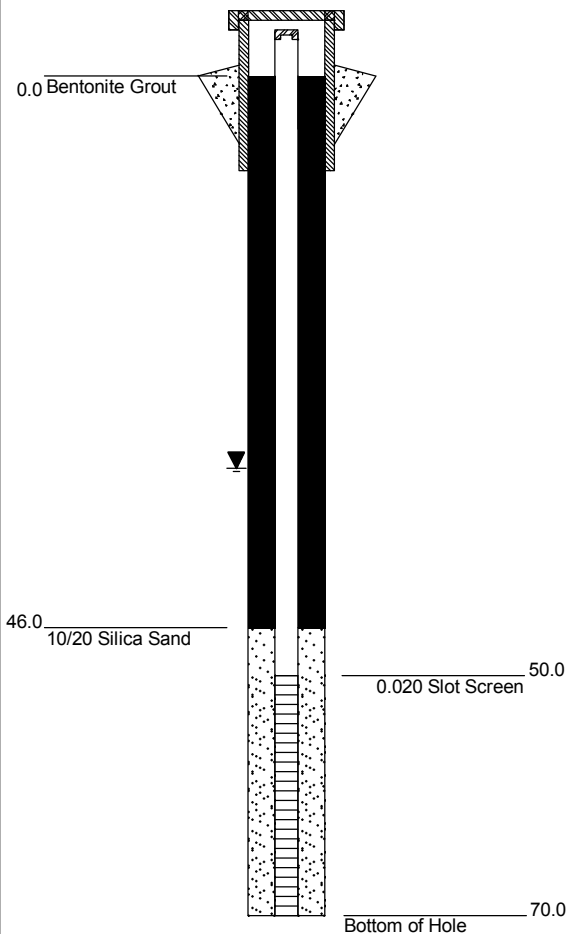

SAMPLE NOTES

GRAPHICS

GEOLOGICAL DESCRIPTION

0.0 - 2.0' **Topsoil**
Dark brown, soil transitioning to shale with depth, dry.

2.0 - 20.0' **Shale**
Blue grey, dolomitic shale, small fracture located at 11 feet with no water associated, dry.

20.0 - 35.0' **Weathered Shale**
Tan, reddish brown, weathered/alterd shale. Dry

35.0 - 55.0' **Granodiorite**
Grey, reddish orange weathered granodiorite. making water at 45 feet (0.5 gpm).

55.0 - 70.0' **Granodiorite**
Dark grey, highly competent granodiorite. No increase in flow.

Client: Tintina Resources
 Project: Black Butte Copper Project
 County: Meagher State: MT
 Property Owner: Bar Z Ranch Inc
 Legal Description: NE, NW, NW S26, T12N, R06E
 Location Description: Middle of CTF toe
 Recorded By: Ashton Montrone
 Drilling Company: Enviromental West
 Driller: Randy
 Drilling Method: Odex
 Drilling Fluids Used: Air
 Purpose of Hole: Install Monitor Well
 Target Aquifer: CTF Toe
 Hole Diameter (in): 6
 Total Depth Drilled (ft): 61

WELL COMPLETION	Y/N	DESCRIPTION	INTERVAL
Well Installed?	Y	2-inch, flush threaded, Sch 40, PVC	+2 to 60
Surface Casing Used?	Y	6-inch, steel casing	+2 to 3
Screen/Perforations?	Y	0.020-inch slot, Sch 40 PVC	40-60
Sand Pack?	Y	10/20 Silica Sand	37-60
Annular Seal?	Y	Bentonite Chips	0.5-37
Surface Seal?	Y	Portland Cement	+0.5-0.5
DEVELOPMENT/SAMPLING			
Well Developed?	Y	surge and pump	
Water Samples Taken?	Y	Commons, Nutrients, Metals	
Boring Samples Taken?	Y	chips	Every 5 feet
Northing: 5179010.377		Easting: 506412.822	
Static Water Level Below MP: 30.26		Surface Casing Height (ft): 2	
Date: 3/28/16		Riser Height (ft): 2	
MP Description: Top of PVC		Ground Surface Elevation (ft): 5841.51	
MP Height Above or Below Ground (ft): 2		MP Elevation (ft): 5844.75	

Remarks:

WELL CONSTRUCTION

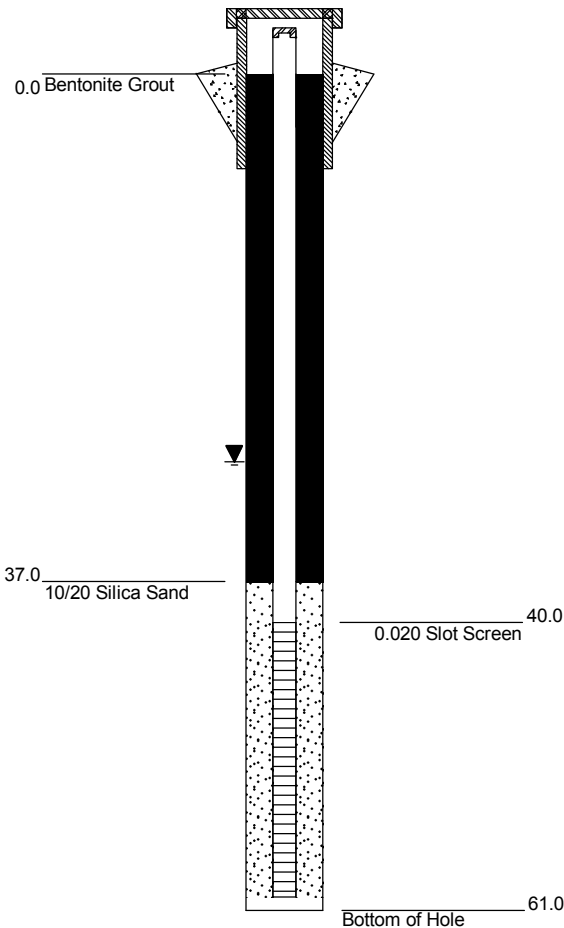

SAMPLE NOTES

GRAPHICS

GEOLOGICAL DESCRIPTION

0.0 - 20.0' **Shale**
 Bluish grey, dolomitic shale, Dry

5.0 - 35.0' **Shale/Dolostone**
 Grey/Blue shale and dolostone, Dry

35.0 - 61.0' **Granodiorite**
 Grey, granodiorite; weathered from 35-40 feet, competent granodiorite from 40-45 feet. Making water at 35 feet., dry from 40-45 feet, wet from 45-70. making 0.5 gpm at bottom of hole.

Client: Tintina Resources
 Project: Black Butte Copper Project
 County: Meagher State: MT
 Property Owner: Bar Z Ranch Inc
 Legal Description: SE, NW, NW S26, T12N, R06E
 Location Description: South of CTF toe
 Recorded By: Ashton Montrone
 Drilling Company: Enviromental West
 Driller: Randy
 Drilling Method: Odex
 Drilling Fluids Used: Air
 Purpose of Hole: Install Monitor Well
 Target Aquifer: CTF Toe
 Hole Diameter (in): 6
 Total Depth Drilled (ft): 40

WELL COMPLETION	Y/N	DESCRIPTION	INTERVAL
Well Installed?	Y	2-inch, flush threaded, Sch 40, PVC	+2 to 40
Surface Casing Used?	Y	6-inch, steel casing	+2 to 3
Screen/Perforations?	Y	0.020-inch slot, Sch 40 PVC	20-40
Sand Pack?	Y	10/20 Silica Sand	17-40
Annular Seal?	Y	Bentonite Chips	0.5-17
Surface Seal?	Y	Portland Cement	+0.5-0.5
DEVELOPMENT/SAMPLING			
Well Developed?	Y	surge and pump	
Water Samples Taken?	Y	Commons, Nutrients, Metals	
Boring Samples Taken?	Y	chips	Every 5 feet
Northing: 5178855.811		Easting: 506477.787	
Static Water Level Below MP: 22.32		Surface Casing Height (ft): 2	
Date: 3/28/16		Riser Height (ft): 2	
MP Description: Top of PVC		Ground Surface Elevation (ft): 5819.07	
MP Height Above or Below Ground (ft): 2		MP Elevation (ft): 5822.48	

Remarks:

WELL CONSTRUCTION

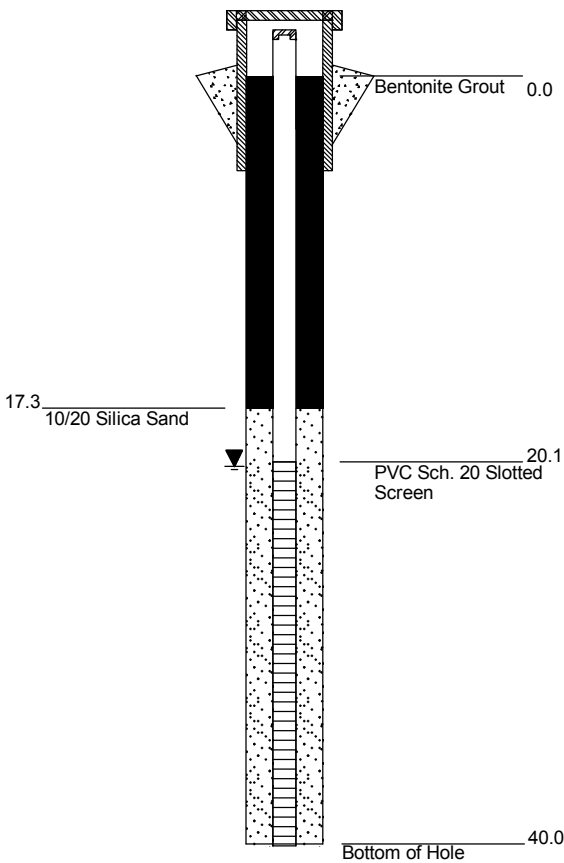

SAMPLE NOTES

GRAPHICS

GEOLOGICAL DESCRIPTION

0.0 - 5.0' Topsoil Brown, fine to coarse, angular sand with silt, dry
5.0 - 20.0' Shale Grey, tan weathered dolomitic shale, dry
20.0 - 30.0' Shale Bluish grey, dolomitic shale. Making water at 29.5 feet.
30.0 - 40.0' Limestone Dark grey, limestone. Making very little water.

Client: Tintina Resources
 Project: Black Butte Copper Project
 County: Meagher State: MT
 Property Owner: Holmstrom Short Ranch LLC
 Legal Description: SW,SE, S30, T12N, R07E
 Location Description: Eastern UIG
 Recorded By: J. Harwood
 Drilling Company: O'Keefe Drilling
 Driller: Scott/Corey
 Drilling Method: DR
 Drilling Fluids Used: Air
 Purpose of Hole: Install Monitor Well
 Target Aquifer: First Water
 Hole Diameter (in): 6
 Total Depth Drilled (ft): 68

WELL COMPLETION	Y/N	DESCRIPTION	INTERVAL
Well Installed?	Y	2-inch, flush threaded, Sch 40, PVC	+2.7 to 66
Surface Casing Used?	Y	6-inch steel	+2.8 to 36
Screen/Perforations?	Y	0.010-inch slot, Sch 40, PVC	56 to 66
Sand Pack?	Y	10/20 Silica Sand	53 to 68
Annular Seal?	Y	Bentonite Chips	0 to 53
Surface Seal?	Y	Cement	0 - 6"

DEVELOPMENT/SAMPLING			
Well Developed?	Y	Air for 1 hour and pumped 3 bore volumes	
Water Samples Taken?	Y	Commons, Nutrients, Metals	
Boring Samples Taken?	Y	chips	Every 5 feet
Northing: 5179376.766		Easting: 508255.625	
Static Water Level Below MP: 39.94		Surface Casing Height (ft): 2.8	
Date: 9/19/16		Riser Height (ft): 2.7	
MP Description: Top of PVC		Ground Surface Elevation (ft): 5761.16	
MP Height Above or Below Ground (ft): 2.7		MP Elevation (ft): 5763.873	

Remarks: Water was encountered below fractured zone (at 52 feet) at 56 feet bgs. Fifteen minute break yielded 5 gallons drilled to 68 feet.

WELL CONSTRUCTION

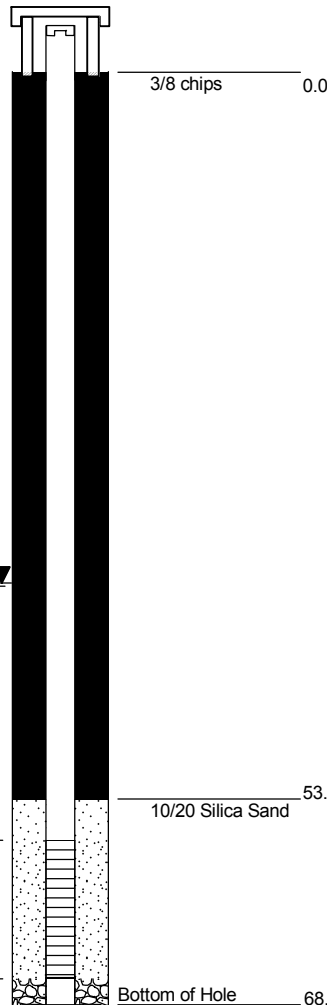

GRAPHICS

GEOLOGICAL DESCRIPTION

0.0 - 1.0'	TOPSOIL Dark brown, sand and silt topsoil with angular-subrounded clasts weathered shale clasts. Dry.
1.0 - 15.0'	SILTY SOIL Buff tan colored silt with moderately weathered shale clasts. Shale is orange-tan to brown, mottled black to tan, very thin laminated with very thin black veins and dendrites (pyrite?), shale is weathered along veins. Clasts have iron oxide fractured surfaces with black dendritics, reacts with HCl. Dry.
15.0 - 20.0'	SILT/SHALE Gray brown silt with angular weak to moderately weathered shale clasts; dark gray to buff tan with iron oxidized fracture surfaces, weak to moderate reaction to HCl. Dry.
20.0 - 25.0'	SHALE Thinly bedded, weakly weathered black shale; black to buff-tan. Some iron surfaces and calcite vein fill; up to 4 mm. Alteration is peripheral to fractures only, weak reaction to HCl. Dry.
25.0 - 30.0'	SHALE Thinly bedded dark gray to black shale as above. Weak reaction to HCl.
30.0 - 40.0'	At 28 feet, less weathering, chips were very angular, small (less than 1/4"), seems to be more competent shale. Dry. SHALE Hard black shale, not weathered, occasional iron oxide fracture surfaces, very thin calcite veins.
39.0 - 39.5'	At 39 - 39.5 feet, weak to moderate weathered black shale; tan-brown to black, includes iron fractured surfaces, very thin calcite veins. Rock mass does not react with HCl. Cuttings returned with fine silt and had silty clay coating.
40.0 - 52.0'	SHALE Non-weathered, thinly bedded black shale with very thin calcite veins. Hard, slower drilling, small, less than 1/4" chip return.
52.0 - 52.5'	SHALE Gray-brown silt with weakly oxidized black shale as above, orange-yellow iron oxide on fracture surfaces.
55.0 - 60.0'	SHALE Thinly bedded black shale with abundant fines, soft drilling, very dusty, thin calcite veins.
56.0 - 66.0'	At 56 feet, one foot into new rod, entered first water, produced approximately 4 gallons until dry. Wet
60.0 - 68.0'	SHALE Very black thinly laminated black shale, abundant fines - silty calcite veins up to 1 cm, shale is calcareous. Wet to damp.

Client: Tintina Resources
 Project: Black Butte Copper Project
 County: Meagher State: MT
 Property Owner: Holmstrom Short Ranch LLC
 Legal Description: NW, NE, S31, T12N, R07E
 Location Description: Eastern UIG
 Recorded By: J. Harwood
 Drilling Company: O'Keefe Drilling
 Driller: Scott/Corey
 Drilling Method: DR
 Drilling Fluids Used: Air
 Purpose of Hole: Install Monitor Well
 Target Aquifer: First Water
 Hole Diameter (in): 6"
 Total Depth Drilled (ft): 80

WELL COMPLETION	Y/N	DESCRIPTION	INTERVAL
Well Installed?	Y	2-inch, flush threaded, Sch 40, PVC	+2.1 to 80
Surface Casing Used?	Y	6-inch steel	+2.3 to 5
Screen/Perforations?	Y	0.010-inch slot, Sch 40, PVC	70 to 80
Sand Pack?	Y	10/20 Silica Sand	66 to 80
Annular Seal?	Y	Bentonite Chips	0 to 66
Surface Seal?	Y	Cement	0 to 6"

DEVELOPMENT/SAMPLING

Well Developed?	Y	Air for 1 hour and pumped 3 bore volumes
Water Samples Taken?	Y	Commons, Nutrients, Metals
Boring Samples Taken?	Y	chips Every 5 feet

Northing: 5179071.066	Easting: 508290.888
Static Water Level Below MP: 39.85	Surface Casing Height (ft): 2.3
Date: 9/19/16	Riser Height (ft): 2.1
MP Description: Top of PVC	Ground Surface Elevation (ft): 5795.26
MP Height Above or Below Ground (ft): 2.1	MP Elevation (ft): 5797.341

Remarks: Water was encountered at 68 feet.

WELL CONSTRUCTION

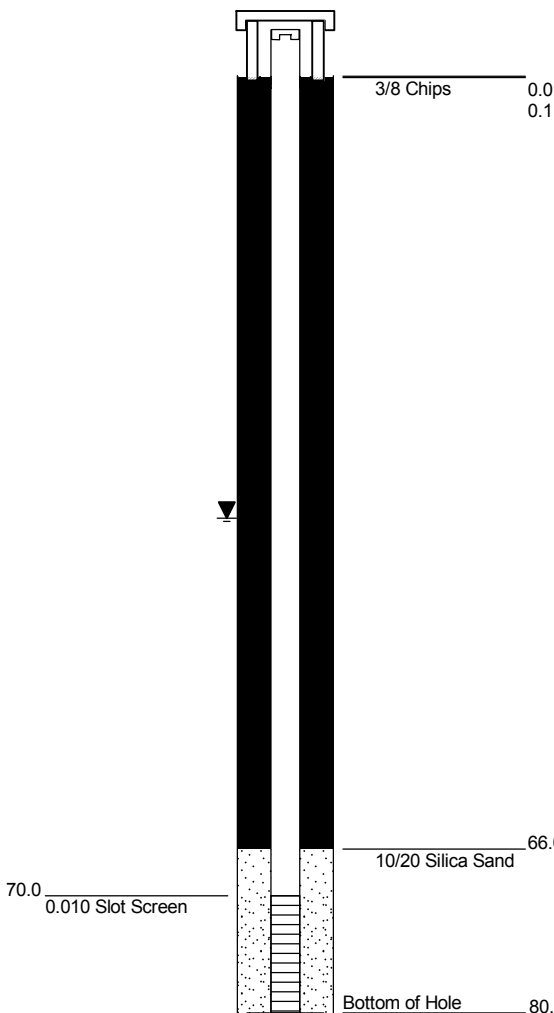

GRAPHICS

GEOLOGICAL DESCRIPTION

0.0 - 1.0' TOPSOIL Dark brown, sand and silt topsoil with angular-subrounded weathered shale clasts, dry.
1.0 - 3.0' SHALE Orange-brown, highly weathered shale and buff tan silt, dry.
3.0 - 5.0' SHALE Buff tan, weathered shale and silty fines, dusty, occasional red-brown fines, dry.
5.0 - 12.0' SILT/SHALE Increased red-brown silt with brown-gray oxidized, silty shale, weakly reaction to HCl, dry.
12.0 - 20.0' SHALE Thinly laminated, weak to moderate oxidation, orange-brown to black shale, with very thin calcite veins, occasional thick calcite vein fill chip, fractured surfaces are weak to moderately oxidized, occasional laminations are red-orange oxidation, dry.
At 17 - 20 feet, Less weathering, decreased silty fines, more competent shales, approximately 40% of return are chips.
20.0 - 35.0' SHALE Weakly weathered black shale with tan-gray silty fines, angular to subangular chips, large fragments up to 3/4 inch. Medium gray to black thinly lam shale, fractured surfaces have common red-orange oxidation. Weak reaction to HCl. Dry.
35.0 - 48.0' SHALE Weak to no weathering, no silty fines, competent shale, slower drilling, fine to coarse angular chips; thinly laminated, dark gray to black, weakly reactive to HCl. Dry.
48.0 - 62.0' SHALE Fractured shale, abundant black powdery fines, soft drilling. Thinly to thick laminated dark gray to black shale, no oxidation, not reactive to HCl, minor very thin calcite veins. Dry.
62.0 - 70.0' SHALE Dark gray shale to light gray shale is very thinly to thickly laminated, weak reaction to HCl. Dry. at 64 feet, dusty, abundant silty-powdery fines with coarse chips, possible shear zone.
at 68 feet, encountered water upon re-entry with additional drilling rod. Wet.
70.0 - 80.0' SHALE Abundant fines, powdery, very dusty, only approximately 10 to 15% small chips, less than 1 cm, weekly reactive to HCl. Ten feet of water at 80 feet at the time of drilling.

Client: Tintina Resources
 Project: Black Butte Copper Project
 County: Meagher State: MT
 Property Owner: Bar Z Ranch Inc
 Legal Description: NE, NE, NW S25, T12N, R06E
 Location Description: East of proposed adit, near adit water table contact
 Recorded By: Bill Thompson
 Drilling Company: H&L Drilling
 Driller: Derrick Toney
 Drilling Method: Air Rotary
 Drilling Fluids Used: Air/Water
 Purpose of Hole: Aquifer Test Well
 Target Aquifer: Bedrock
 Hole Diameter (in): 10
 Total Depth Drilled (ft): 213

WELL COMPLETION	Y/N	DESCRIPTION	INTERVAL
Well Installed?	Y	6-inch, steel casing	+1.5 to 213
Surface Casing Used?	Y	6-inch, steel casing	
Screen/Perforations?	Y	Casing Perforator	171-211
Sand Pack?	Y	Gravel	108-213
Annular Seal?	Y	Bentonite Grout	2-108
Surface Seal?	Y	Portland Cement	+0.5-2
DEVELOPMENT/SAMPLING			
Well Developed?	Y	Air for 1.5 hrs	
Water Samples Taken?	Y	Commons, Nutrients, Metals	
Boring Samples Taken?	N		
Northing: 5180698.4		Easting: 506301.42	
Static Water Level Below MP: 102.66		Surface Casing Height (ft):	
Date: 11/24/14		Ground Surface Elevation (ft): 5913.74	
MP Description: Top of Steel		MP Elevation (ft): 5913.74	
MP Height Above or Below Ground (ft): 1.7			

Remarks:

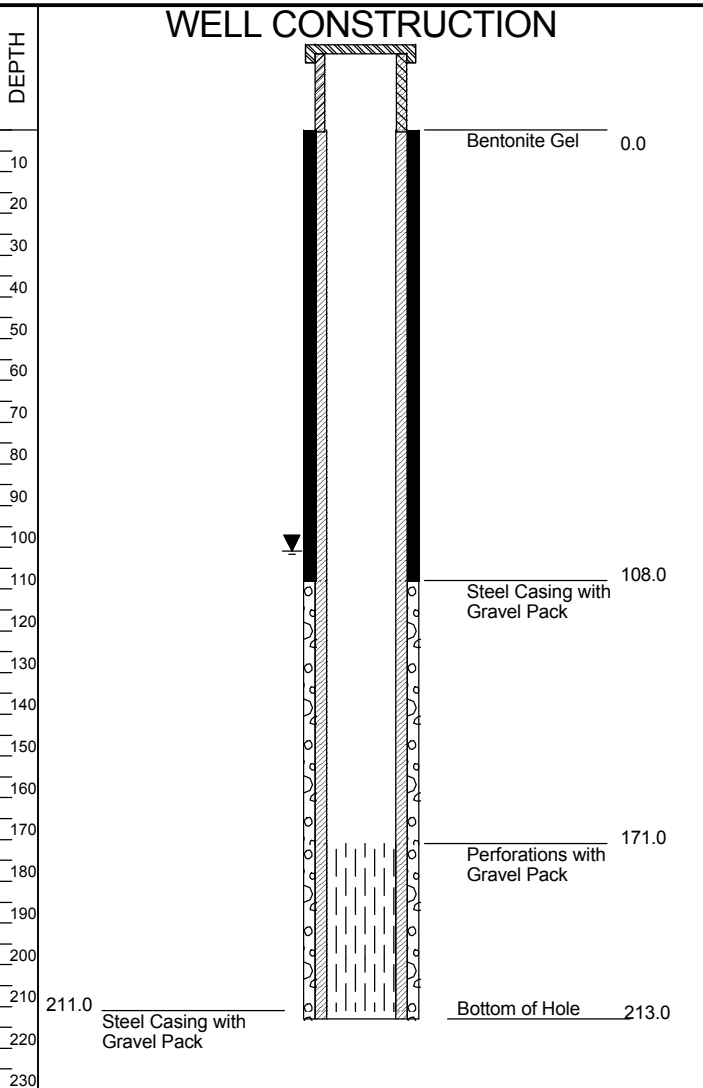

GRAPHICS	GEOLOGICAL DESCRIPTION
[Pattern]	0.0 - 4.0' Dolomitic Shale Dark gray, with brown weathered surfaces, dolomitic shale. Dry
[Pattern]	4.0 - 70.0' Dolomitic Shale Dark gray dolomitic shale with some white calcite veins. Brown/orange iron staining and calcite on fracture surfaces. Increasingly fractured and deeply weathered/oxidized appearance with depth. Some fragments gossen like with red/orange coloring. Dry
[Pattern]	70.0 - 100.0' Dolomitic Shale Dark gray dolomitic shale with less deeply weathered/fractured characteristics. Start to drill harder at 90 feet. Dry
[Pattern]	100.0 - 110.0' Shale Dark gray dolomitic shale with dark gray to black very thinly bedded silic shale. Less dolomitic shale with depth. Not making water
[Pattern]	110.0 - 140.0' Shale Dark gray to black very thinly bedded silic shale. Drill cutting returns are blockier with traces of white calcite veining at 130-140 feet. No weathered surfaces observed below 110 feet. Not making water
[Pattern]	140.0 - 170.0' Shale Dark gray silic shale and dolomitic shale. Blew on hole at 155' with trickle of water then dried up
[Pattern]	170.0 - 213.0' Dolomitic Shale Dark gray dolomitic shale, less thinly bedded with some calcite veins. Drilling a little softer at 190 feet. Not making water.

Client: Tintina Resources
 Project: Black Butte Copper Project
 County: Meagher State: MT
 Property Owner: Holmstrom, Rose
 Legal Description: SW, SW, SE S24, T12N, R06E
 Location Description: South of proposed adit near SC11-020 borehole
 Recorded By: Greg Bryce
 Drilling Company: H&L Drilling
 Driller: Derrick Toney
 Drilling Method: Air Rotary
 Drilling Fluids Used: Air/Water/Foam
 Purpose of Hole: Aquifer Test Well
 Target Aquifer: Bedrock
 Hole Diameter (in): 10
 Total Depth Drilled (ft): 215

WELL COMPLETION	Y/N	DESCRIPTION	INTERVAL
Well Installed?	Y	6-inch, steel casing	+1.5 to 215
Surface Casing Used?	Y	6-inch, steel casing	
Screen/Perforations?	Y	Casing Perforator	132-212
Sand Pack?	Y	Gravel	121-215
Annular Seal?	Y	Bentonite Grout	2-121
Surface Seal?	Y	Portland Cement	+0.5-2

DEVELOPMENT/SAMPLING	
Well Developed?	Y Air for 3 hrs, jetting
Water Samples Taken?	Y Commons, Nutrients, Metals
Boring Samples Taken?	N

Northing: 5180865.03	Easting: 506443.15
Static Water Level Below MP: 60.37	Surface Casing Height (ft):
Date: 11/24/14	Ground Surface Elevation (ft): 5794.88
MP Description: Top of Steel	MP Elevation (ft): 5794.88
MP Height Above or Below Ground (ft): 1.8	

Remarks:

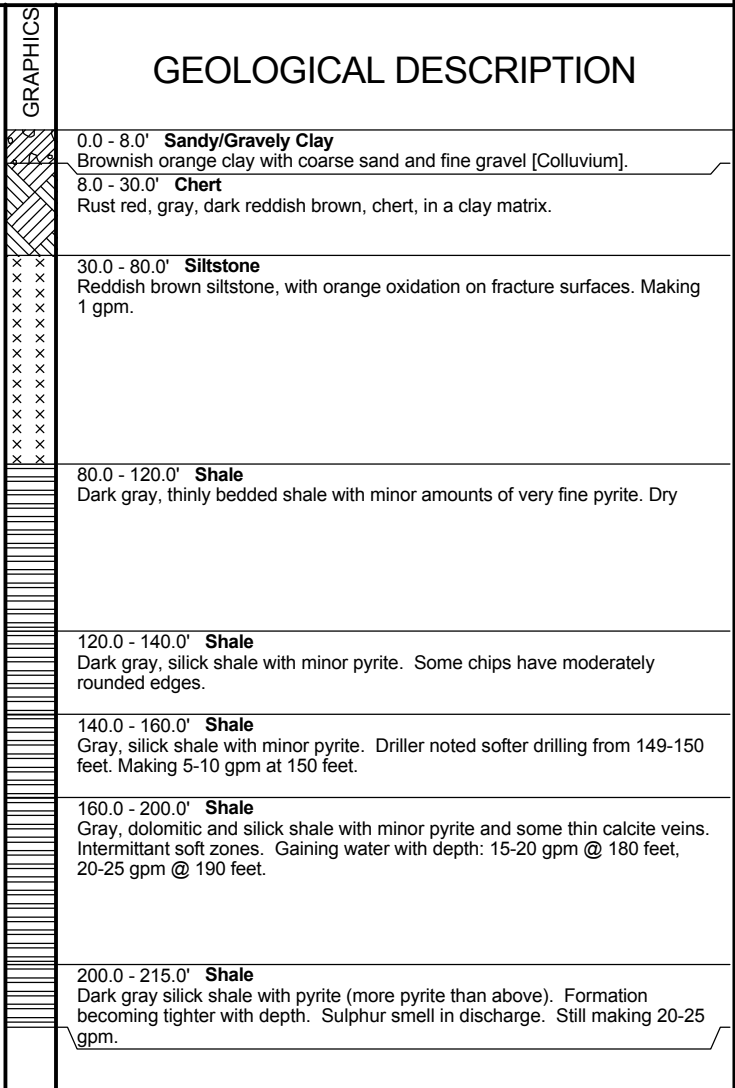
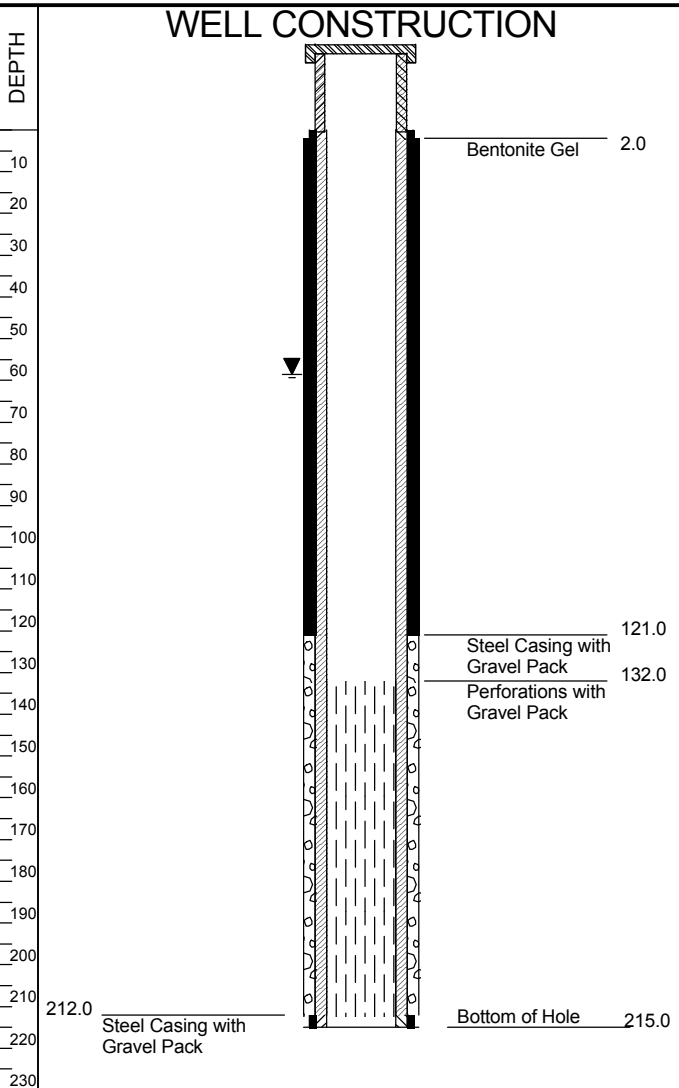

Client: Tintina Resources
 Project: Black Butte Copper Project
 County: Meagher State: MT
 Property Owner: Bar Z Ranch Inc
 Legal Description: NW, NE, NE S25, T12N, R06E
 Location Description: Middle section of proposed adit, near Coon Creek & SC11-057
 Recorded By: Larry Johnson
 Drilling Company: H&L Drilling
 Driller: Derrick Toney
 Drilling Method: Air Rotary
 Drilling Fluids Used: Water/Foam
 Purpose of Hole: Aquifer Test Well
 Target Aquifer: Bedrock
 Hole Diameter (in): 10
 Total Depth Drilled (ft): 131

WELL COMPLETION	Y/N	DESCRIPTION	INTERVAL
Well Installed?	Y	6-inch, steel casing	+2 to 130
Surface Casing Used?	Y	10-inch, steel casing	+2 to 27.5
Screen/Perforations?	Y	Perforated 6" Steel	90-127
Sand Pack?	Y	Gravel and 10/20 Silica Sand	Gravel:84-130 Sand:80-84
Annular Seal?	Y	Bentonite Grout	1-80
Surface Seal?	Y	Portland Cement	0-1

DEVELOPMENT/SAMPLING	
Well Developed?	Y Air for 1 hour
Water Samples Taken?	Y Commons, Nutrients, Metals
Boring Samples Taken?	Y Every 10 feet

Northing: 5180479.42 Easting: 506846.43
 Static Water Level Below MP: 14.09 Surface Casing Height (ft):
 Date: 11/24/14 Ground Surface Elevation (ft): 5657.42
 MP Description: Top of Steel MP Elevation (ft): 5657.42
 MP Height Above or Below Ground (ft): 2

Remarks: Produced 18 gpm water

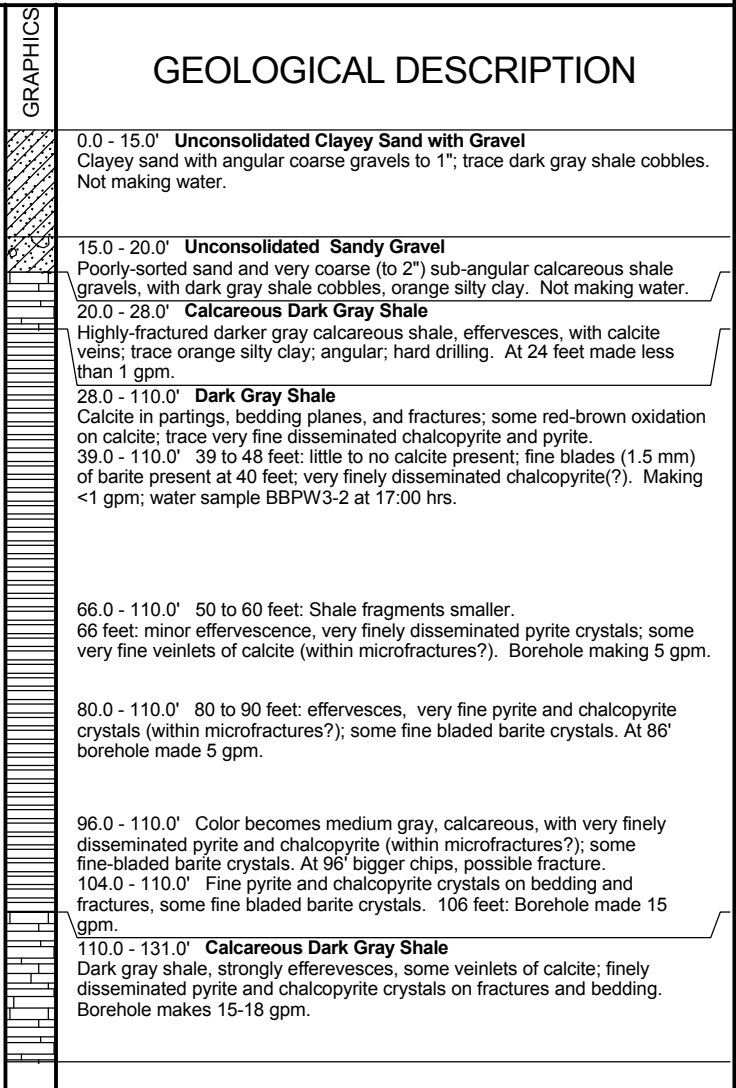
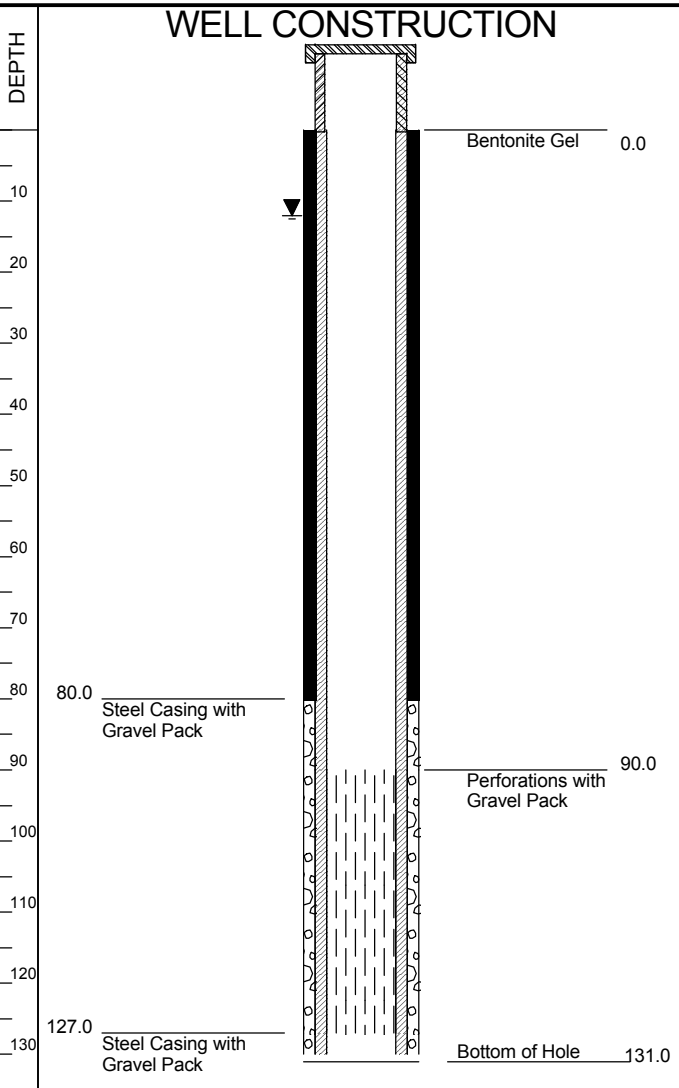

DOMESTIC_WELL2 K:\GINT\PROJECTS\11048.GPJ HYDHLN2.GDT 3/30/15

Client: Tintina Resources
 Project: Black Butte Copper Project
 County: Meagher State: MT
 Property Owner: Bar Z Ranch Inc
 Legal Description: SW, NE, NE S25, T12N, R06E
 Location Description: Western portion of proposed adit, east of SC11-016.
 Recorded By: Larry Johnson
 Drilling Company: H&L Drilling
 Driller: Derrick Toney
 Drilling Method: Air Rotary
 Drilling Fluids Used: Water/Foam
 Purpose of Hole: Aquifer Test Well
 Target Aquifer: Bedrock
 Hole Diameter (in): 10
 Total Depth Drilled (ft): 242

WELL COMPLETION	Y/N	DESCRIPTION	INTERVAL
Well Installed?	Y	6-inch, steel casing	+2 to 242
Surface Casing Used?	Y	10-inch, steel casing	+2 to 93
Screen/Perforations?	Y	Perforated 6" Steel	200-239
Sand Pack?	Y	Gravel and 10/20 Silica Sand	Grvl:195-242 Sand: 191-195
Annular Seal?	Y	Bentonite Grout	1-191
Surface Seal?	Y	Portland Cement	0-1

DEVELOPMENT/SAMPLING	
Well Developed?	Y Air for 1 hour
Water Samples Taken?	Y Commons, Nutrients, Metals
Boring Samples Taken?	Y Every 10 feet
Northing: 5180688.26	Easting: 506901.79
Static Water Level Below MP: 52.78	Surface Casing Height (ft):
Date: 11/24/14	Ground Surface Elevation (ft): 5680.01
MP Description: Top of Steel	MP Elevation (ft): 5680.01
MP Height Above or Below Ground (ft): 2	

Remarks: Produced 1 gpm water

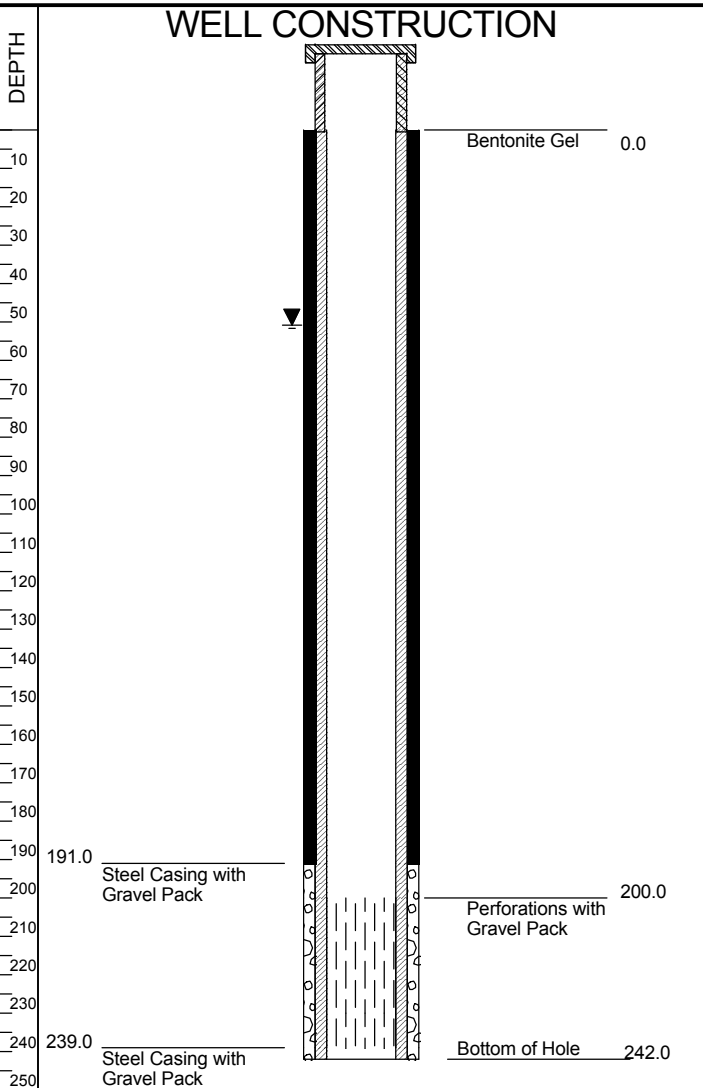

DEPTH (ft)	GRAPHICS	GEOLOGICAL DESCRIPTION
0.0 - 6.0'	[Symbol]	Unconsolidated Sandy Clay Dark gray clay with fine to coarse sand, about 3%.
6.0 - 50.0'	[Symbol]	Unconsolidated Sandy Clay with Fine Gravel Cuttings consist of 10% multilithic, sub-angular rock fragments, sand- to fine gravel-sized, in predominantly red/brown (oxidized) clay 90%. 20.0 - 50.0' Rock fragments include black shale and gray quartz. 30.0 - 50.0' Color becomes tan to brown, cuttings are 75% clay; 25% multilithic, sub-angular to sub-rounded rock fragments, clasts are sand-sized to fine gravel-sized.
50.0 - 118.0'	[Symbol]	Unconsolidated Sandy Gravel Cuttings are 85% multilithic, sub-rounded to sub-angular fine gravel and 15% sub-rounded coarse sand. At 70-90 feet, fragments more angular, with trace fine sand and silt. At 84 feet, borehole is not producing water. 93-95 feet: Granite boulder. Cuttings are 80% multilithic, sub-angular fine gravel, with increasing percentage of shale clasts; 10% sub-angular to sub-rounded, fine to coarse sand; 10% tan clay. Shale clasts effervesce.
118.0 - 130.0'	[Symbol]	Dark Gray Shale interbedded with Siltstone Hard drilling. Cuttings are 95% rock fragments, predominantly shale with gray/tan siltstone; about 5% tan sandy clay. Shale clasts have a trace of fine pyrite crystals and some fine-bladed barite crystals. At 125 feet borehole is making 30gpm.
130.0 - 140.0'	[Symbol]	Black Shale Cuttings are 90% fine black shale rock fragments; 9% sub-angular medium-coarse grained sand; and 1% fine bladed barite crystals.
140.0 - 150.0'	[Symbol]	Dark Gray Shale Cuttings are 85% sub-angular sand-sized to gravel-sized rock fragments, primarily shale, very fine disseminated pyrite (or chalcopyrite?) crystals (within microfractures?); 14% fine to medium-grained multi-lithic sand; about 1% bladed barite crystals. Orange coating (oxidation?) on nearly all shale and sand clasts. At 145 feet borehole is making 15gpm.
150.0 - 240.0'	[Symbol]	Dark Gray Shale interbedded with Siltstone Cuttings are large clasts, dark gray shale and light gray to light tan sandy siltstone; siltstone clasts may contain very fine orange (oxidized?) streaks; many shale clasts effervesce, though not all; trace pyrite crystals, trace barite crystals (bladed, stubby, acicular). 165-205 feet: Borehole is making about 20gpm. 190-200 feet: Quartz sandstone and siltstone in return with shale cuttings. Shale and siltstone cuttings in return are fine- to coarse-sand sized; orange oxidation on a few clasts; trace very fine disseminated pyrite (chalcopyrite?) crystals and barite crystals.

DOMESTIC_WELL2 K:\GINT\PROJECTS\11048.GPJ HYDHLN2.GDT 3/30/15

DEPTH	WELL CONSTRUCTION	GRAPHICS	GEOLOGICAL DESCRIPTION
260 270 280 290 300 310 320 330 340 350 360 370 380 390 400 410 420 430 440 450 460 470 480 490 500 510 520 530 540 550 560 570 580 590 600 610 620 630 640 650			<p>Cuttings are 80% fine-coarse sand-sized shale and siltstone clasts, 20% fine gravel-sized clasts; shale has finely disseminated pyrite (chalcopyrite?) crystals and barite crystals.</p> <p>230.0 - 240.0' Cuttings are gravel sized, calcareous (strongly effervesce), very finely disseminated minor pyrite (chalcopyrite?) crystals, barite absent; very few siltstone clasts.</p>

DOMESTIC_WELL2 K:\GINT\PROJECTS\11048.GPJ HYDHLN2.GDT 3/30/15

Client: Tintina Resources
 Project: Black Butte Copper Project
 County: Meagher State: MT
 Property Owner: Holmstrom Short Ranch LLC
 Legal Description: NW, SW, SE S24, T12N, R06E
 Location Description: North of proposed Upper Johnny Lee ore body
 Recorded By: Greg Davis
 Drilling Company: National EWP
 Driller: Jake Jesson
 Drilling Method: Air Rotary
 Drilling Fluids Used: Air, Water, Foam
 Purpose of Hole: Aquifer Test Well
 Target Aquifer: Bedrock
 Hole Diameter (in): 10
 Total Depth Drilled (ft): 565

WELL COMPLETION	Y/N	DESCRIPTION	INTERVAL
Well Installed?	Y	6-inch, steel casing	+2 to 555
Surface Casing Used?	Y	12-inch, steel casing	0 to 25
Screen/Perforations?	Y	0.020-inch Factory Slot Steel	515-500
Sand Pack?	Y	3/8" Gravel	508-560
Annular Seal?	Y	Bentonite/Cement Grout	0 to 503
Surface Seal?	Y	Portland Cement	+0.5-0.5

DEVELOPMENT/SAMPLING	
Well Developed?	Y Air for 4 hours
Water Samples Taken?	Y Commons, Nutrients, Metals
Boring Samples Taken?	Y Chips every 10 feet
Northing: 5181172.77	Easting: 506490.68
Static Water Level Below MP: 471.49	Surface Casing Height (ft):
Date: 11/24/14	Ground Surface Elevation (ft): 5913.22
MP Description: Top of Steel	MP Elevation (ft): 5915.49
MP Height Above or Below Ground (ft): 2	

Remarks: Produced 1-2 gpm during development

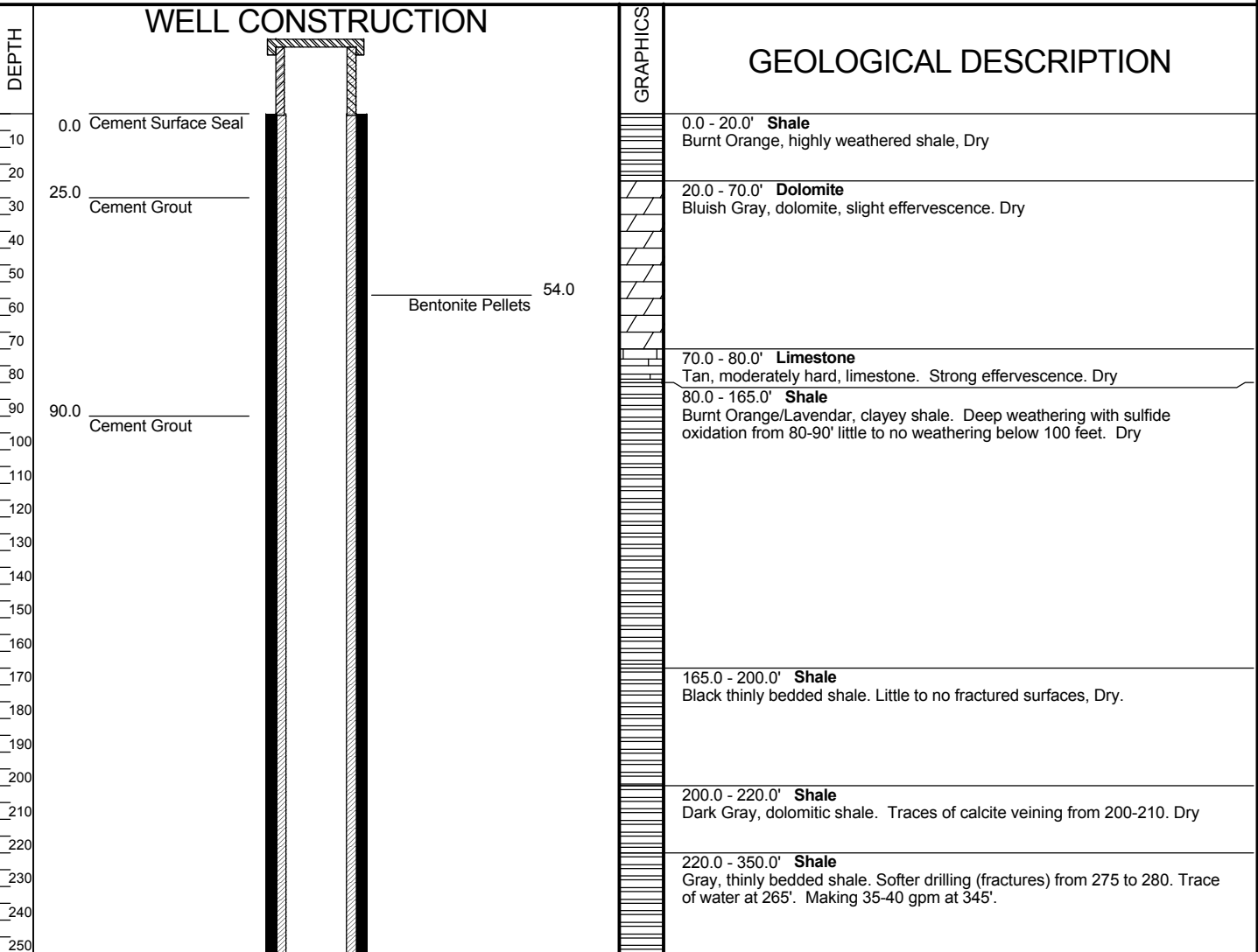

DOMESTIC_WELL2 K:\GINT\PROJECTS\11048.GPJ HYDHLN2.GDT 4/8/15

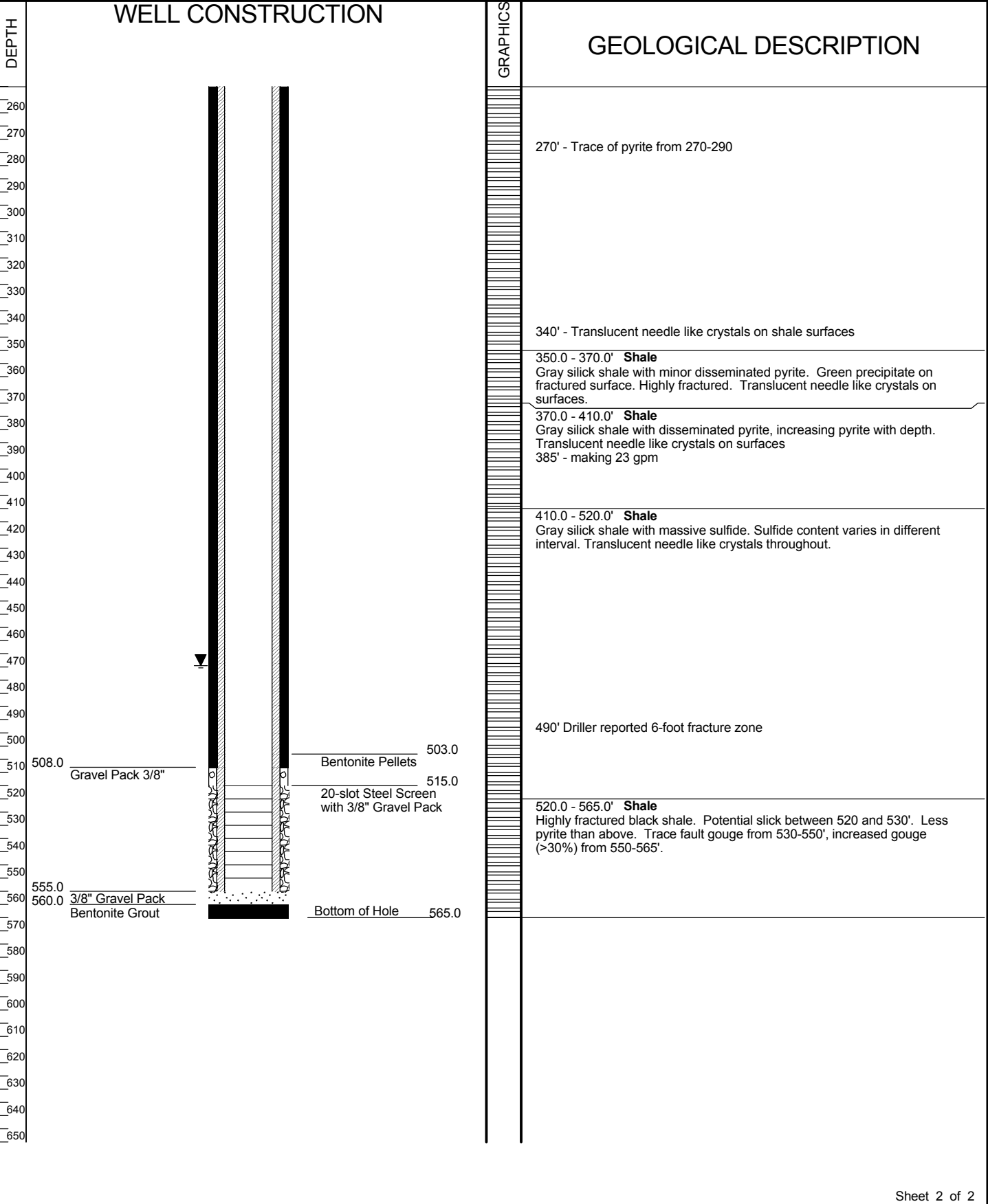

DOMESTIC_WELL2 K:\GINT\PROJECTS\11048.GPJ HYDHLN2.GDT 4/8/15

Client: Tintina Resources
 Project: Black Butte Copper Project
 County: Meagher State: MT
 Property Owner: Holmstrom Short Ranch LLC
 Legal Description: NW, SW, SE S24, T12N, R06E
 Location Description:
 Recorded By: Greg B., Greg D., Lisa B.
 Drilling Company: National EWP
 Driller: Jake Jesson
 Drilling Method: Air Rotary, Mud Rotary
 Drilling Fluids Used: Air, Water, Mud
 Purpose of Hole: Aquifer Test Well
 Target Aquifer: Bedrock
 Hole Diameter (in): 10
 Total Depth Drilled (ft): 1234

WELL COMPLETION	Y/N	DESCRIPTION	INTERVAL
Well Installed?	Y	6-inch, steel casing	+2 to 1204
Surface Casing Used?	Y	12-inch, steel casing	0 to 43
Screen/Perforations?	Y	0.020-inch Factory Slot Steel	1164 to 1204
Sand Pack?	Y	3/8" Gravel	1159 to 1209
Annular Seal?	Y	Bentonite/Cement Grout	0 to 1159
Surface Seal?	Y	Portland Cement	+0.5 to 0.5

DEVELOPMENT/SAMPLING	
Well Developed?	Y Air for 4 hours
Water Samples Taken?	Y Commons, Nutrients, Metals
Boring Samples Taken?	Y Chips every 10 feet

Northing: 5181085.67 Easting: 506477.44
 Static Water Level Below MP: 312.98 Surface Casing Height (ft):
 Date: 11/24/14 Riser Height (ft): 2
 MP Description: Top of Steel Ground Surface Elevation (ft): 5895.43
 MP Height Above or Below Ground (ft): 2 MP Elevation (ft): 5897.4

Remarks: 3/30/2015: well abandoned, cemented gravel pack and screen interval
 Well re-occupied: 4/1/2015 as PW-6N

WELL CONSTRUCTION



SAMPLE NOTES

GRAPHICS

GEOLOGICAL DESCRIPTION

0.0 - 0.5' Top Soil Top Soil
0.5 - 37.0' Dolomite Blue grey, dolomite. slight efferevecense, Dry
37.0 - 42.5' Shale Grey, hard shale with soft zone at 41'
42.5 - 50.0' Shale Grey, hard shale with sulfides (some massive), highly oxidized, moderately weathered. Not making water
50.0 - 92.0' Shale No Returns softer drilling
92.0 - 110.0' Shale Yellow orange, orange chert with minor grey shale. More shale with depth
110.0 - 145.0' Shale grey to dark grey, dolomitic shale with calcite veins.
145.0 - 180.0' Shale Dark grey, shale with minor fine grained pyrite. Not making water
180.0 - 270.0' Shale Dark grey shale with fine to coarse grained pyrite. Coarser pyrite with depth, massive pyrite around 268-270'. Making <5 gpm at 260 feet.
270.0 - 385.0' USZ Dark grey silicified shale with massive sulfide. Making 3-5 gpm.

DOMESTIC_WELL1 K:\GINT\PROJECTS\11048.GPJ HYDHLN2.GDT 8/24/15

WELL CONSTRUCTION

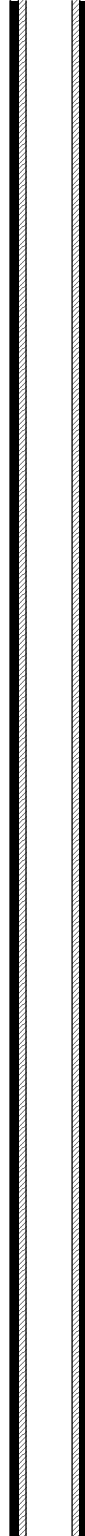

SAMPLE NOTES

GRAPHICS

GEOLOGICAL DESCRIPTION

385.0 - 450.0' **UCZ**
 Dark grey shale with massive chalcopryite. Making 30-40 gpm @ 450'

450.0 - 460.0' **USZ/UCZ**
 Dark grey silicified shale with massive and disseminated sulfide, minor chalcopryite

460.0 - 760.0' **Shale**
 Dark grey dolomitic shale, minor calcite veins. Driller reported highly fractured rock from 612 to 640. Making 65-75 gpm at 640'; 70 gpm at 760'

760.0 - 940.0' **VVF**
 Dark grey, highly weathered shale. Highly fractured with fault gouge throughout. Making 65-70 gpm at 810'

860-880 Dolomitic shale

880-920 intervals of clay and hard shale, with varying sulfide content to 920'

Noted slicks at 920' and 940' Minor sulfide

940.0 - 1060.0' **Shale**
 Dark grey, dolomitic shale with minor calcite veins and intermittent very fine pyrite (<3%)

DOMESTIC_WELL1 K:\GINT\PROJECTS\11048.GPJ HYDHLN2.GDT 8/24/15

WELL CONSTRUCTION

SAMPLE NOTES

GRAPHICS

GEOLOGICAL DESCRIPTION

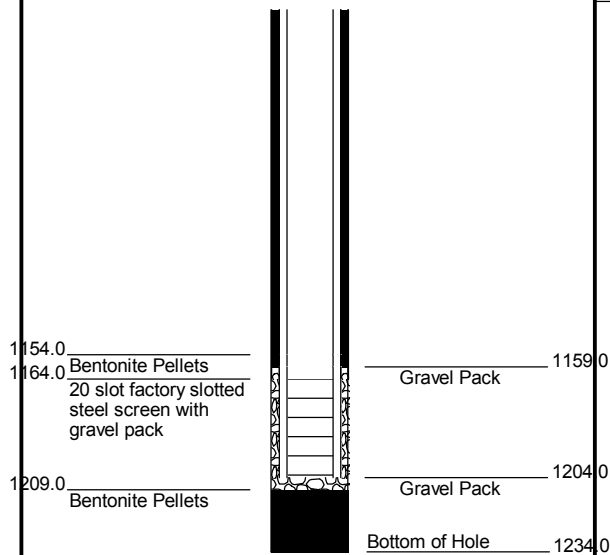

1060.0 - 1110.0' **Shale**
 Dark grey dolomitic shale with fine to coarse pyrite (1-3%), intermittent calcite veins

1110.0 - 1184.0' **Shale**
 Dark grey dolomitic shale, with traces of coarse pyrite (<1%); with bluish grey clay (fault gouge). Buttress Fault

1184.0 - 1234.0' **Neihart Quartzite**
 tan with red to purplish red grained quartzite.

Client: Tintina Resources
 Project: Black Butte Copper Project
 County: Meagher State: MT
 Property Owner: Holmstrom Short Ranch LLC
 Legal Description: NW, SW, SE S24, T12N, R06E
 Location Description:
 Recorded By: Greg B., Greg D., Lisa B.
 Drilling Company: National EWP
 Driller: Jake Jesson
 Drilling Method: Air Rotary, Mud Rotary
 Drilling Fluids Used: Air, Water, Mud
 Purpose of Hole: Aquifer Test Well
 Target Aquifer: Bedrock
 Hole Diameter (in): 10
 Total Depth Drilled (ft): 1358

WELL COMPLETION	Y/N	DESCRIPTION	INTERVAL
Well Installed?	Y	6-inch, steel casing	+2 to 1204
Surface Casing Used?	Y	12-inch, steel casing	0 to 43
Screen/Perforations?	Y	0.020-inch Factory Slot Steel	1164 to 1204
Sand Pack?	Y	3/8" Gravel	1159 to 1209
Annular Seal?	Y	Bentonite/Cement Grout	0 to 1159
Surface Seal?	Y	Portland Cement	+0.5 to 0.5

DEVELOPMENT/SAMPLING	
Well Developed?	Y Air for 4 hours
Water Samples Taken?	Y Commons, Nutrients, Metals
Boring Samples Taken?	Y Chips every 10 feet

Northing: 5181085.67 Easting: 506477.44
 Static Water Level Below MP: 305 Surface Casing Height (ft):
 Date: 4/2/2015 Riser Height (ft): 2
 MP Description: Top of Steel Ground Surface Elevation (ft): 5895.43
 MP Height Above or Below Ground (ft): 2 MP Elevation (ft): 5897.4

Remarks: Deepened PW-6 following abandonment of screen and gravel pack
 New well (PW-6N) completed open hole from bottom of cement seal to 1358 feet.

WELL CONSTRUCTION

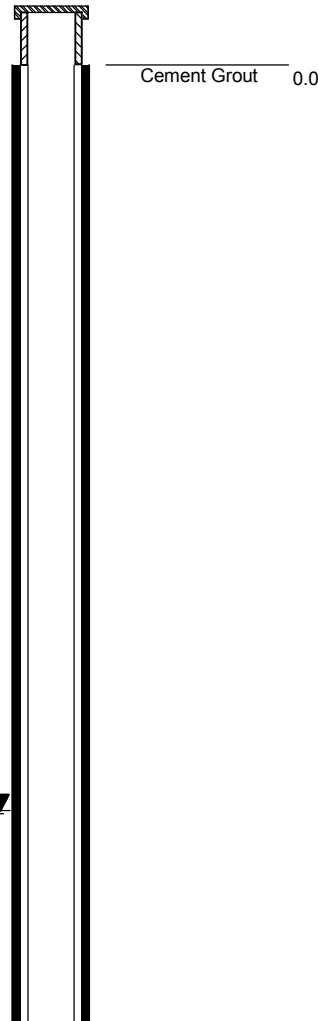

SAMPLE NOTES

GRAPHICS

GEOLOGICAL DESCRIPTION

0.0 - 0.5' Top Soil Top Soil
0.5 - 37.0' Dolomite Blue grey, dolomite. slight efferecense, Dry
37.0 - 42.5' Shale Grey, hard shale with soft zone at 41'
42.5 - 50.0' Shale Grey, hard shale with sulfides (some massive), highly oxidized, moderately weathered. Not making water
50.0 - 92.0' Shale No Returns softer drilling
92.0 - 110.0' Shale Yellow orange, orange chert with minor grey shale. More shale with depth
110.0 - 145.0' Shale grey to dark grey, dolomitic shale with calcite veins.
145.0 - 180.0' Shale Dark grey, shale with minor fine grained pyrite. Not making water
180.0 - 270.0' Shale Dark grey shale with fine to coarse grained pyrite. Coarser pyrite with depth, massive pyrite around 268-270'. Making <5 gpm at 260 feet.
270.0 - 385.0' USZ Dark grey silicified shale with massive sulfide. Making 3-5 gpm.

DOMESTIC_WELL1 K:\GINT\PROJECTS\11048.GPJ HYDHLN2.GDT 8/20/15

WELL CONSTRUCTION

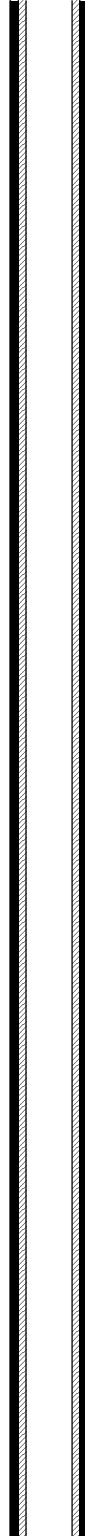

SAMPLE NOTES

GRAPHICS

GEOLOGICAL DESCRIPTION

385.0 - 450.0' **UCZ**
 Dark grey shale with massive chalcopryrite. Making 30-40 gpm @ 450'

450.0 - 460.0' **USZ/UCZ**
 Dark grey silicified shale with massive and disseminated sulfide, minor chalcopryrite

460.0 - 760.0' **Shale**
 Dark grey dolomitic shale, minor calcite veins. Driller reported highly fractured rock from 612 to 640. Making 65-75 gpm at 640'; 70 gpm at 760'

760.0 - 940.0' **VVF**
 Dark grey, highly weathered shale. Highly fractured with fault gouge throughout. Making 65-70 gpm at 810'

860-880 Dolomitic shale

880-920 intervals of clay and hard shale, with varying sulfide content to 920'

Noted slicks at 920' and 940' Minor sulfide

940.0 - 1060.0' **Shale**
 Dark grey, dolomitic shale with minor calcite veins and intermittent very fine pyrite (<3%)

WELL CONSTRUCTION	SAMPLE NOTES	GRAPHICS	GEOLOGICAL DESCRIPTION
			<p>1060.0 - 1110.0' Shale Dark grey dolomitic shale with fine to coarse pyrite (1-3%), intermittent calcite veins</p> <p>1110.0 - 1184.0' Shale Dark grey dolomitic shale, with traces of coarse pyrite (<1%); with bluish grey clay (fault gouge). Buttress Fault</p> <p>1184.0 - 1234.0' Neihart Quartzite Tan with red to purplish red grained quartzite.</p> <p>1234.0 - 1310.0' Neihart Quartzite Reddish purple, tan quartzite, intermittent areas of hard drilling making <10gpm</p> <p>1310.0 - 1358.0' Neihart Quartzite White quartzite few yellow and brown grains, mostly pulverized, drilling hard, 10-30ft/day</p> <p>1340 well produced 100gpm water, flow returned to 25gpm after 10 mins</p> <p>Drilling easier, numerous fractures produceces >500gpm during air lifting</p>

DOMESTIC_WELL1 K:\GINT\PROJECTS\11048.GPJ HYDHLN2.GDT 8/20/15

Client: Tintina Resources
 Project: Black Butte Copper Project
 County: Meagher State: MT
 Property Owner: Bar Z Ranch Inc
 Legal Description: SW, SW, SW S19, T12N, R06E
 Location Description: In Hay Meadow middle portion of Lower Johnny Lee ore body
 Recorded By: Jim Sheffer, Larry Johnson
 Drilling Company: Nationa EWP
 Driller: Jake Jesson
 Drilling Method: Mud Rotary
 Drilling Fluids Used: Air, Water, Mud
 Purpose of Hole: Aquifer Test Well
 Target Aquifer: Bedrock
 Hole Diameter (in): 10
 Total Depth Drilled (ft): 1350

WELL COMPLETION	Y/N	DESCRIPTION	INTERVAL
Well Installed?	Y	6-inch, steel casing	+2 to 1346
Surface Casing Used?	Y	12-inch, steel casing	0 to 64
Screen/Perforations?	Y	0.020-inch Factory Slot Steel	1306-1346
Sand Pack?	Y	3/8" Gravel	1300-1346
Annular Seal?	Y	Bentonite/Cement Grout	0 to 1300
Surface Seal?	Y	Portland Cement	+0.5 to 0.5

DEVELOPMENT/SAMPLING

Well Developed?	Y	Air for 4 hours
Water Samples Taken?	Y	Commons, Nutrients, Metals
Boring Samples Taken?	Y	Chips every 10 feet

Northing: 5180867.59 Easting: 507122.89
 Static Water Level Below MP: _____ Surface Casing Height (ft): _____
 Date: _____ Ground Surface Elevation (ft): 5609.11
 MP Description: Top of Steel MP Elevation (ft): 5611.15
 MP Height Above or Below Ground (ft): 2

Remarks:

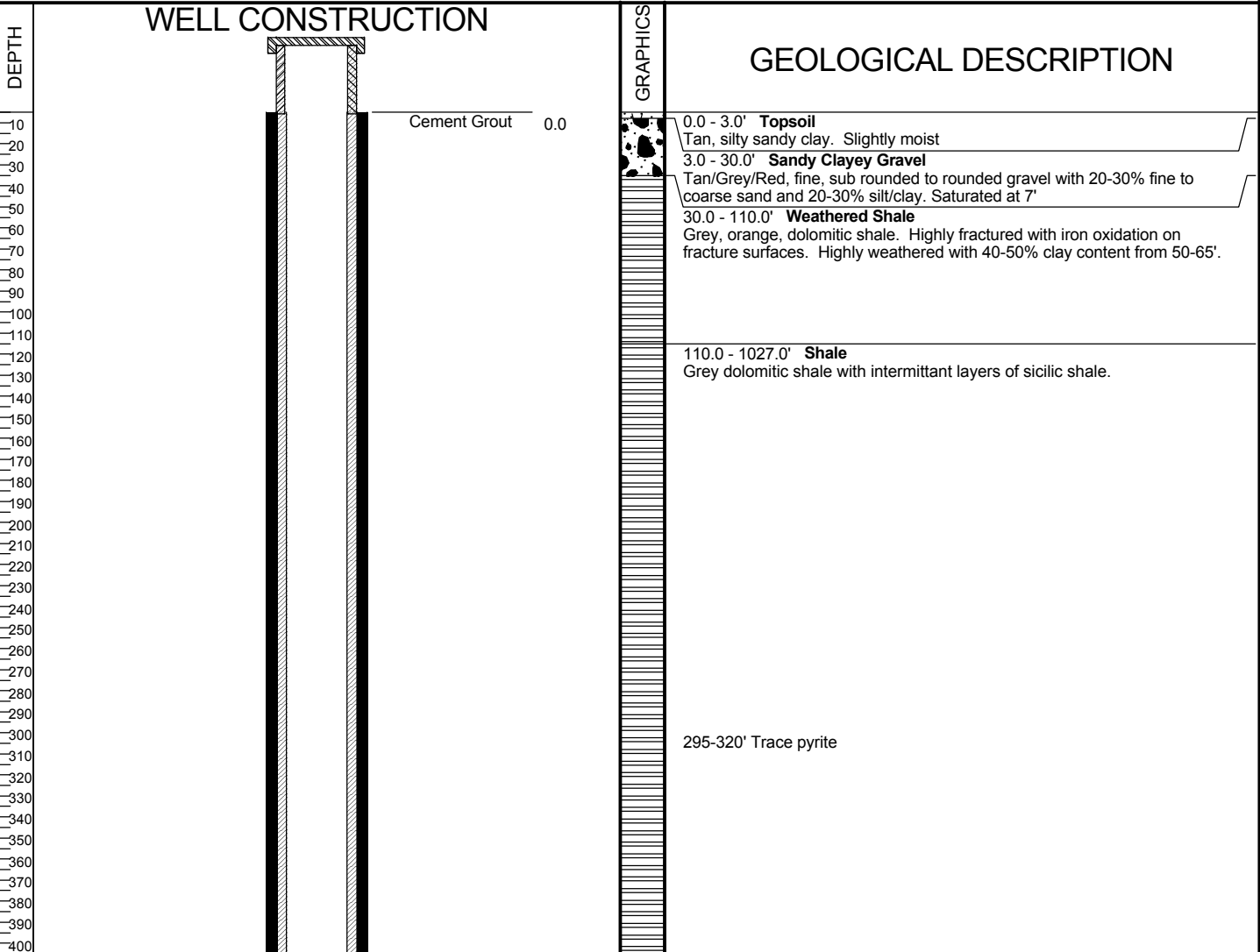

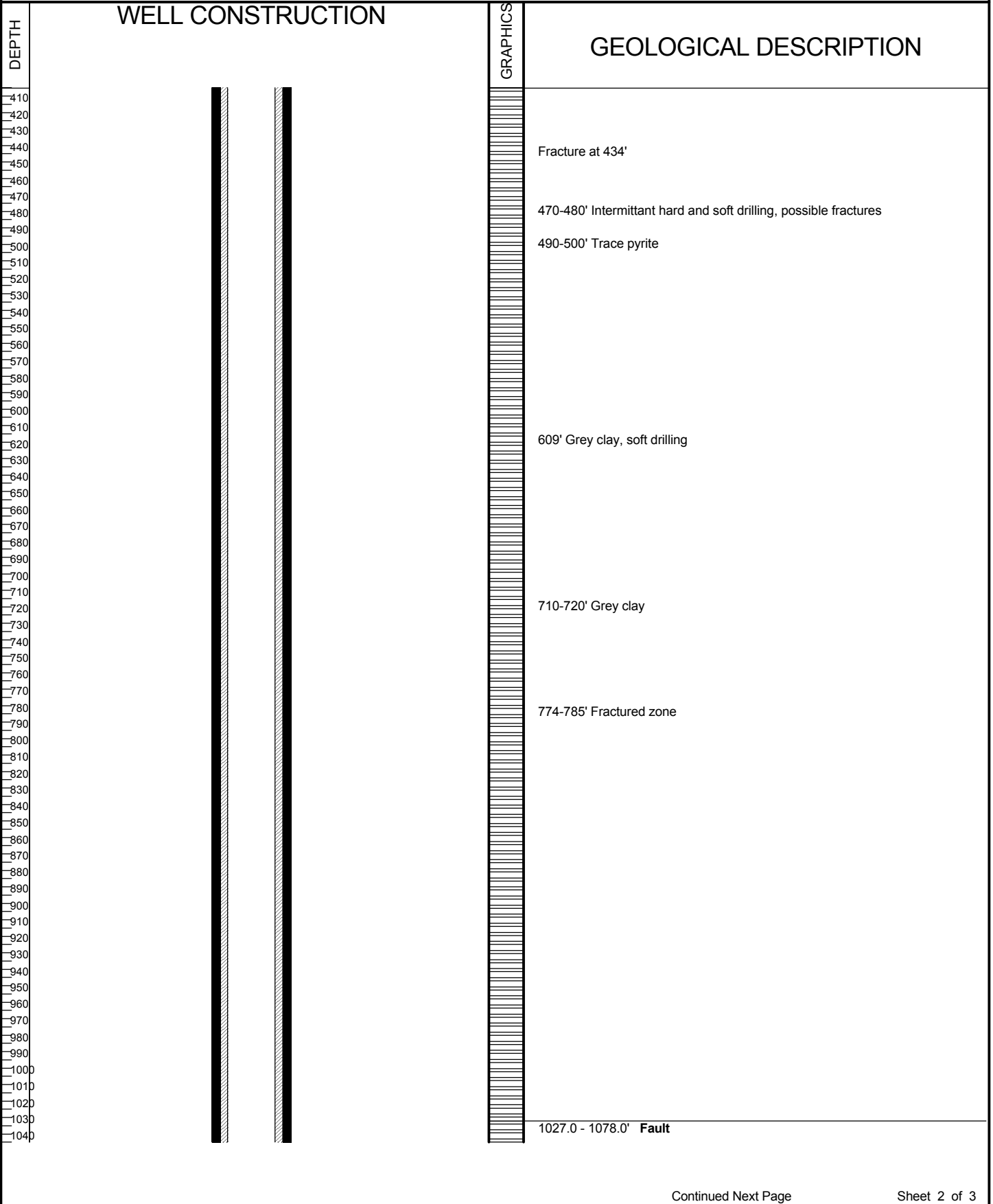

DOMESTIC_WELL2 K:\GINT\PROJECTS\11048.GPJ HYDHLN2.GDT 3/30/15

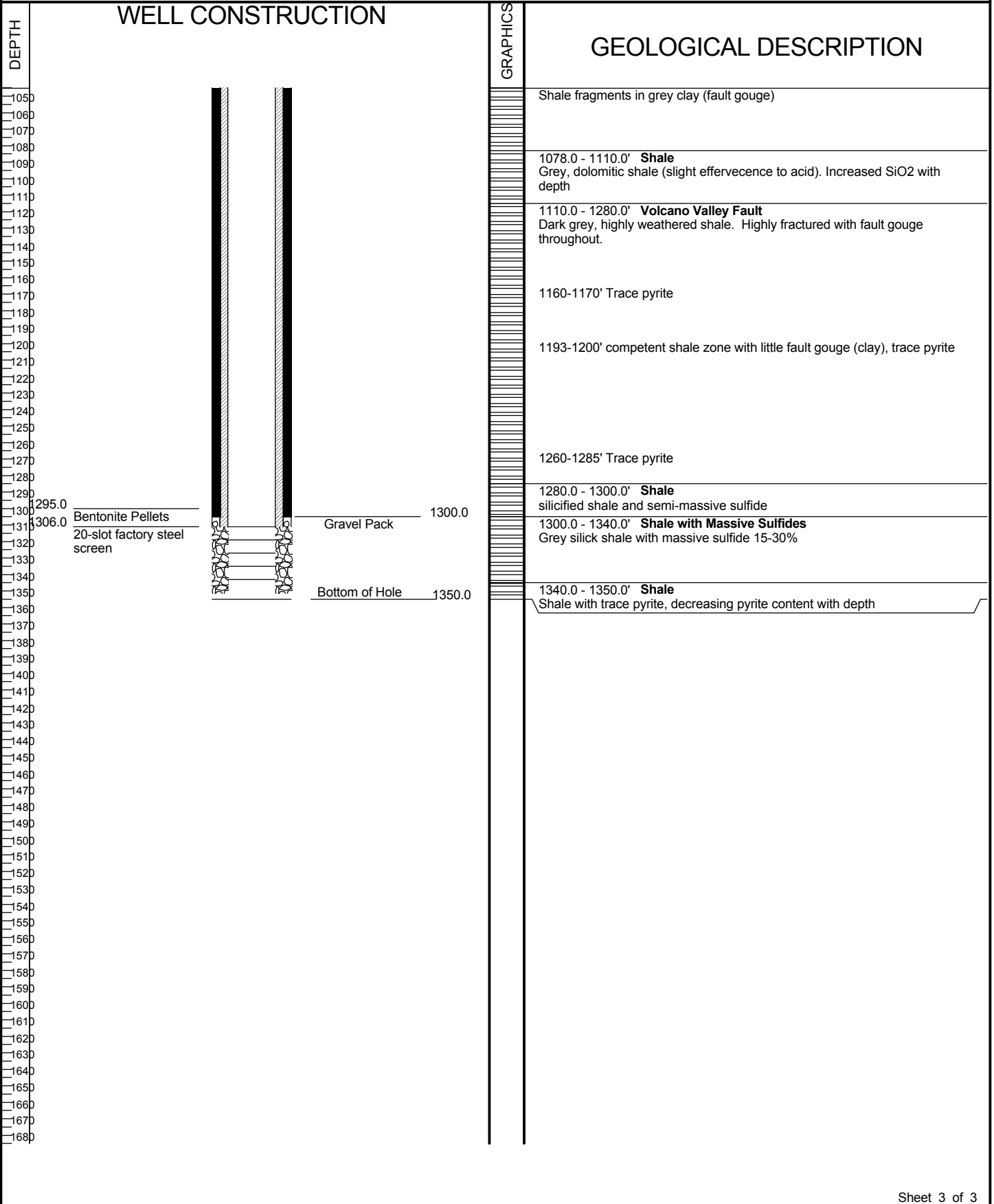

DOMESTIC_WELL2 K:\GINT\PROJECTS\11048.GPJ HYDHLN2.GDT 3/30/15

Client: Tintina Resources
 Project: Black Butte Copper Project
 County: Meagher State: MT
 Property Owner: Bar Z Ranch Inc
 Legal Description: SW, NE, NE S25, T12N, R06E
 Location Description: Western portion of proposed adit, east of SC11-016.
 Recorded By: Greg Bryce
 Drilling Company: H&L Drilling
 Driller: Derrick Toney
 Drilling Method: Air Rotary
 Drilling Fluids Used: Air, Water, Foam
 Purpose of Hole: Aquifer Test Well
 Target Aquifer: Bedrock
 Hole Diameter (in): 8
 Total Depth Drilled (ft): 184

WELL COMPLETION	Y/N	DESCRIPTION	INTERVAL
Well Installed?	Y	4-inch, flush threaded, Sch 40, PVC	+2 to 178.5
Surface Casing Used?	Y	8-inch, steel casing	+1.5 to 78.5
Screen/Perforations?	Y	0.020-inch slot, Sch 40 PVC	138.5-178.5
Sand Pack?	Y	Gravel and 10/20 Silica Sand	Grvl: 131.5-178.5 Sd: 129.5-131.5
Annular Seal?	Y	Bentonite Grout	0-129.5
Surface Seal?	Y	Portland Cement	0-1

DEVELOPMENT/SAMPLING			
Well Developed?	Y	Air for 0.5 hrs	
Water Samples Taken?	Y	Commons, Nutrients, Metals	
Boring Samples Taken?	Y	Every 10 feet	chips

Northing: 5180695.53 Easting: 506846.19
 Static Water Level Below MP: 45.52 Surface Casing Height (ft): 1.5
 Date: 11/24/14 Riser Height (ft): 1.4
 MP Description: Top of Steel Ground Surface Elevation (ft): 5679.12
 MP Height Above or Below Ground (ft): 2 MP Elevation (ft): 5680.6

Remarks: Produced 12 gpm

WELL CONSTRUCTION

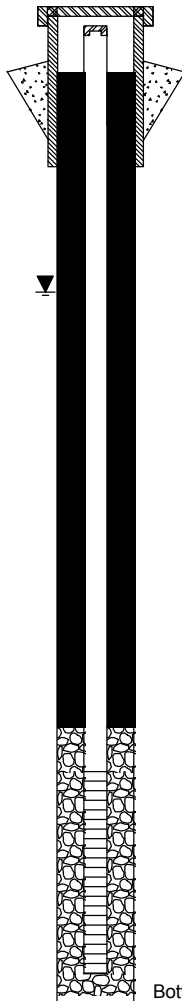

Bottom of Hole 184.0

SAMPLE NOTES

GRAPHICS

GEOLOGICAL DESCRIPTION

0.0 - 60.0'	Sandy clay Moderately oxidized, clay with 30%-40% sub-rounded medium sand. No water.
60.0 - 90.0'	Quartzite, siltstone, shale Gray/white angular/sub-angular quartzite, cream colored angular/sub-angular siltstones, and angular dark shale in 10% clay matrix. No water.
90.0 - 100.0'	Clay with sand fragments Low oxidation brownish gray clay with 10%-20% medium sand sized shale fragments. No water.
100.0 - 130.0'	Shale, quartzite, siltstone Gray/white angular/sub-angular quartzite, dark gray angular/sub-angular siltstones, and angular dark shale with oxidation on some facies in 30% clay matrix. No water.
130.0 - 150.0'	Shale Angular black shale with disseminated sulfides. 5-8 gpm at 140'.
150.0 - 160.0'	Shale, quartzite, siltstone Angular black shale, sub-angular/sub-rounded moderately weathered siltstone, sub-angular quartzite. Massive and disseminated sulfides on shale and quartzite. 10 gpm.
160.0 - 184.0'	Shale Angular and sub angular black shale. Small amount of disseminated sulfides. 10-15 gpm.

Client: Tintina Resources
 Project: Black Butte Copper Project
 County: Meagher State: MT
 Property Owner: Bar Z Ranch Inc
 Legal Description: NW, NW, NE S25, T12N, R06E
 Location Description: North of Dry Creek near center of UCZ
 Recorded By: Greg Bryce/Ashton Montrone
 Drilling Company: H&L Drilling
 Driller: Derrick Toney
 Drilling Method: Air Rotary
 Drilling Fluids Used: Air, Water, Foam
 Purpose of Hole: Aquifer Test Well
 Target Aquifer: Bedrock
 Hole Diameter (in): 8
 Total Depth Drilled (ft): 255.5

WELL COMPLETION	Y/N	DESCRIPTION	INTERVAL
Well Installed?	Y	4-inch, flush threaded, Sch 40, PVC	+1.5 to 255.5
Surface Casing Used?	Y	8-inch, steel casing	+1.5 to 58.5
Screen/Perforations?	Y	0.020-inch slot, Sch 40 PVC	215.5-255.5
Sand Pack?	Y	Gravel and 10/20 Silica Sand	Grvl: 208.5-255.5 Sd: 208.5-212.5
Annular Seal?	Y	Bentonite Grout	0-208.5
Surface Seal?	Y	Portland Cement	0-1

DEVELOPMENT/SAMPLING			
Well Developed?	Y	Air for 1.5 hrs	
Water Samples Taken?	Y	Commons, Nutrients, Metals	
Boring Samples Taken?	Y	Every 10 feet	chips

Northing: 5180721.88	Easting: 506598.38
Static Water Level Below MP: 41.66	Surface Casing Height (ft): 1.5
Date: 11/24/14	Riser Height (ft): 1.4
MP Description: Top of Steel	Ground Surface Elevation (ft): 5743.59
MP Height Above or Below Ground (ft): 2	MP Elevation (ft): 5745.052

Remarks: Produced 7.5 gpm water

WELL CONSTRUCTION

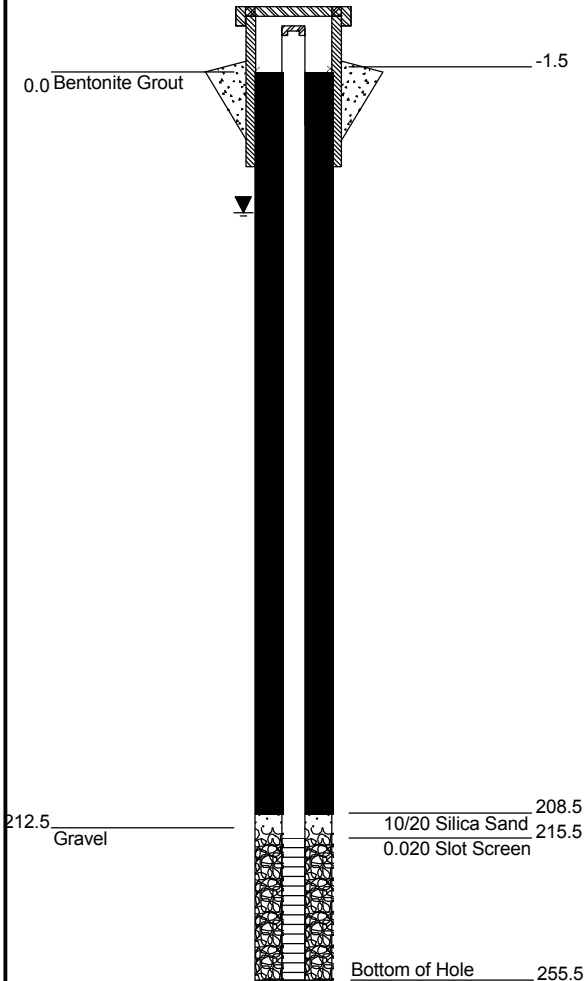

SAMPLE NOTES

GRAPHICS

GEOLOGICAL DESCRIPTION

0.0 - 30.0'	Sandy clay Low to moderate oxidation of clay. 30%-50% angular to sub-angular coarse sand. 2 gpm at 20'.
30.0 - 50.0'	Highly oxidized sandy clay High oxidation of clay. 30%-50% angular to sub-angular coarse sand. 2 gpm at 20'.
50.0 - 60.0'	Siltstone Highly weathered white siltstone. Very soft and rounded. 2 gpm
60.0 - 90.0'	Siltstones, shale, gossan Angular and sub-angular siltstone, shale, and highly weathered gossan. 25 gpm at 90'.
90.0 - 130.0'	Shale Black shale with some diagenic gypsum crystals on the surface. Some oxidation on the surface of the shale between 90-100. 30 gpm at 140'.
130.0 - 160.0'	Shale Gray shale with disseminated sulfides and some massive sulfide. Mostly pyrite with some chalcocopyrite. 30 gpm.
160.0 - 200.0'	Shale Large amounts of massive and disseminated sulfides on gray shale. Relatively equal pyrite and chalcocopyrite. 50 gpm.
200.0 - 220.0'	Shale Shale with barite. Decreasing pyrite/chalcocopyrite, both disseminated and massive. 50 gpm.
220.0 - 257.0'	Shale Black shale with some diagenic cupreous on the surface. Lensing of pyrite/chalcocopyrite. 50 gpm.

Client: Tintina Resources
 Project: Black Butte Copper Project
 County: Meagher State: MT
 Property Owner: Bar Z Ranch Inc
 Legal Description: NW, NW, NE S25, T12N, R06E
 Location Description: North of Dry Creek near center of UCZ
 Recorded By: Greg Bryce/Ashton Montrone
 Drilling Company: H&L Drilling
 Driller: Derrick Toney
 Drilling Method: Air Rotary
 Drilling Fluids Used: Air, Water, Foam
 Purpose of Hole: Aquifer Test Well
 Target Aquifer: Bedrock
 Hole Diameter (in): 8
 Total Depth Drilled (ft): 369.5

WELL COMPLETION	Y/N	DESCRIPTION	INTERVAL
Well Installed?	Y	4-inch, flush threaded, Sch 40, PVC	+1.5 to 358.5
Surface Casing Used?	Y	8-inch, steel casing	+1.5 to 73.5
Screen/Perforations?	Y	0.020-inch slot, Sch 40 PVC	318.5-358.5
Sand Pack?	Y	Gravel and 10/20 Silica Sand	Grvl: 309.5-369.5 Sd: 309.5-299.5
Annular Seal?	Y	Bentonite Grout	0-299.5
Surface Seal?	Y	Portland Cement	0-1
DEVELOPMENT/SAMPLING			
Well Developed?	Y	Air for 1.5 hrs	
Water Samples Taken?	Y	Commons, Nutrients, Metals	
Boring Samples Taken?	Y	Every 10 feet	chips
Northing: 5180721.88		Easting: 506593.55	
Static Water Level Below MP: 45.14		Surface Casing Height (ft): 1.5	
Date: 11/24/14		Riser Height (ft): 1.4	
MP Description: Top of Steel		Ground Surface Elevation (ft): 5743.57	
MP Height Above or Below Ground (ft): 2		MP Elevation (ft): 5744.84	

Remarks: Making ~1 gpm

WELL CONSTRUCTION

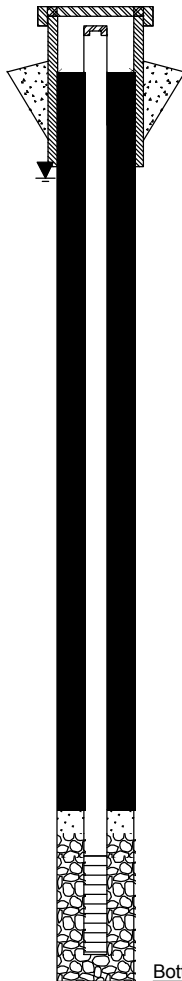

SAMPLE NOTES

GRAPHICS

GEOLOGICAL DESCRIPTION

0.0 - 20.0' **Sandy clay**
 Low oxidized tan clay with 10%-20% angular to sub-angular medium orange sand. 20 gpm at 20'.

20.0 - 60.0' **Siltstone**
 Angular to sub-angular moderately weathered yellow and red siltstones. Moderate oxidation on 40%-50% of facies. 20-30 gpm at 30'.

60.0 - 70.0' **Shale and siltstones**
 Mix of shale (70%-80%) and siltstones(20%-10%) in clay matrix. Sub-angular to sub-rounded moderately oxidized shale, sub rounded siltstone. 20-30 gpm.

70.0 - 100.0' **Shale**
 Light gray sub-angular to sub-rounded highly weathered shale with 30%-40% oxidized facies in ~5% clay matrix. 10% gossan. 40-45 gpm at 90'.

100.0 - 130.0' **Shale**
 Dark gray angular shale, <10% oxidized facies. Some disseminated sulfides. 40-45 gpm.

130.0 - 150.0' **Shale**
 Dark gray angular/sub-angular shale with white quartzite inclusions. Abundant disseminated sulfides with occasional massive sulfides. 40-45 gpm.

150.0 - 190.0' **Shale**
 Dark gray angular shale with disseminated sulfides with occasional massive sulfides. ~10% angular yellow siltstone. 40-45 gpm.

190.0 - 230.0' **Shale and barite**
 Light gray sub-angular shale with 10%-30% barite inclusions. Considerable massive pyrite and chalcopryrite increasing with depth. Occasional specks of copper. 50-75 gpm at 200'.

230.0 - 250.0' **Shale**
 Light gray sub-angular shale with extensive disseminated sulfides and some massive sulfides. 50-75 gpm.

250.0 - 260.0' **Shale**
 Light gray sub-angular shale mixed with dark gray sub-angular shale with quartzite inclusions. 50-75 gpm.

260.0 - 270.0' **Shale**
 Mostly dark gray angular/sub-angular shale with some light gray sub-angular shale. Fewer disseminated sulfides and massive sulfides. 50-75 gpm.

270.0 - 290.0' **Shale**
 Mostly light gray sub-angular shale with ~20% dark gray sub-angular shale. Extensive disseminated sulfides and moderate massive sulfides. 50-75 gpm.

290.0 - 310.0' **Shale**
 Mostly light gray sub-angular shale with ~20% dark gray sub-angular shale. Extensive disseminated sulfides and extensive massive sulfides. 75-100 gpm.

310.0 - 320.0' **Shale**

WELL CONSTRUCTION

SAMPLE NOTES

GRAPHICS

GEOLOGICAL DESCRIPTION

Mostly dark gray angular/sub-angular shale with some (20%) light gray angular/sub-angular shale. Decreasing disseminated sulfides and massive sulfides. 75-100 gpm.

320.0 - 360.0' **Shale**

Dark gray sub-angular shale. Some infrequent disseminated and massive pyrite. 75-100 gpm.

360.0 - 370.0' **Shale**

Black shale with little disseminated sulfides but some massive sulfides. 100 gpm.

MONTANA WELL LOG REPORT

Form No. 603 R2-04

Well ID# SC15-198

This log reports the activities of a licensed Montana well driller and serves as the official record of work done within the borehole and casing and describes the amount of water encountered. **This form is to be completed by the driller and filed with MBMG within 60 days of completion of the work.** Acquiring Water Rights is the well owner's responsibility and is not accomplished by the filing of this report.

Well log information is stored in the Groundwater Information Center at the Montana Bureau of Mines and Geology (Butte) and water right information is stored in the Water Rights Bureau records (Helena).

For fields that are not applicable, enter NA. Record additional information in the REMARKS section.

1. WELL OWNER:
 Name TINTINA ALASKA EXPLORATION, INC
 Mailing address 17 EAST MAIN
WHITE SULPHUR SPRINGS, MT 59645

2. WELL LOCATION: List ¼ from smallest to largest
 _____ ¼ _____ ¼ NE ¼ SE ¼, Section 25
 Township R20N Range 6E County MEADWELL
 Lot _____, Tract/Blk _____ Subdivision Name _____
 Certificate of Survey _____
 Well Address _____
 GPS Yes No
 Latitude N 46° 46.273 Longitude W 110° 54.818
 Error as reported by GPS locator (± feet) 9 FT
 Horizontal datum NAD27 WGS84

3. PROPOSED USE: Domestic Stock Irrigation
 Public water supply Monitoring Well
 Geothermal Closed System Open System ReInjection
 Extraction H₂O Temp _____ Number of Wells in System _____
 Other: _____

4. TYPE OF WORK:
 New well Deepen existing well Abandon existing well
 Method: Cable Rotary Other: CORE

5. WELL CONSTRUCTION DETAILS:
Borehole:
 Dia. 5 in. from 0 ft. to 57 ft.
 Dia. 4 in. from 57 ft. to 97 ft.
 Dia. _____ in. from _____ ft. to _____ ft.
Casing:
 Steel: Wall thickness _____ Threaded Welded
 Dia. _____ in. from _____ ft. to _____ ft.
 Dia. _____ in. from _____ ft. to _____ ft.
 Casing Shoe: Yes No
 Plastic: Pressure Rating 5.40 lbs. Threaded Welded
 Dia. 1.5 in. from 0 ft. to 60 ft.
Perforations/Slotted Pipe:
 Type of perforator used _____
 Size of perforations/slots _____ in. by _____ in.
 _____ no. of perforations/slots from _____ ft. to _____ ft.
 _____ no. of perforations/slots from _____ ft. to _____ ft.
Screens: Yes No
 Material PVC
 Dia. 1.5 Slot size 0.020 from 60.0 ft. to 70.0 ft.
 Dia. _____ Slot size _____ from _____ ft. to _____ ft.
Gravel Packed: Yes No
 Size of gravel 10/20
 Gravel placed from 74.0 ft. to 51.7 ft.
Packer: Yes No
 Type _____ Depth(s) _____
Grout: Material used BENTONITE GROUT
 Depth from _____ ft. to _____ ft. OR Continuous feed

6. WELL TEST DATA:
 A well test is required for all wells. (See details on well log report cover.)
 Static water level 32.6 ft. below top of casing or
 Closed-in artesian pressure _____ psi.
 How was test flow measured:
 bucket/stopwatch, weir, flume, flowmeter, etc _____
 Yellowstone Controlled Groundwater Area - Water Temperature _____ °F
 AQUIFER TEST DATA FORM ATTACHED

Test - 1 hour minimum
 Drawdown is the amount water level is lowered below static level.
 All depth measurements shall be from the top of the well casing.
 Time of recovery is hours/minutes since pumping stopped.

Air test*
 _____ gpm with drill stem set at _____ ft. for _____ hours
 Time of recovery _____ hrs/min. Recovery water level _____ ft.

OR Baller test*
 _____ gpm with _____ ft. of drawdown after _____ hours
 Time of recovery _____ hrs/min. Recovery water level _____ ft.

OR Pump test*
 Depth pump set for test _____ ft.
 _____ gpm pump rate with _____ ft. of drawdown after _____ hrs pumping
 Time of recovery _____ hrs/min. Recovery water level _____ ft.

OR Flowing Artesian*
 _____ gpm for _____ hours
 Flow controlled by _____
*During the well test the discharge rate shall be as uniform as possible. This rate may or may not be the sustainable yield of the well. Sustainable yield does not include the reservoir of the well casing.

7. WELL LOG: Record depth(s) that water is encountered.

Depth, Feet		Material: color/rock and type/descriptor (example: blue/shale/hard, or brown/gravel/water, or brown/sand/heaving)
From	To	
0	2	TOP SOIL
2	99	SHALE

ADDITIONAL SHEETS ATTACHED

8. DATE WELL COMPLETED: 3/22/15

9. REMARKS: AREA ABOVE AND BELOW SAND SEALED WITH COATED BENTONITE PELLETS

10. DRILLER/CONTRACTOR'S CERTIFICATION:
 All work performed and reported in this well log is in compliance with the Montana well construction standards. This report is true to the best of my knowledge.
 Name, firm, or corporation (print) RUEN DRILLING, INC
 Address P.O. BOX 267, CLARROCK, ID 83811
 Signature [Signature]
 Date 3/25/15 License no. 554197
 License type: MWC WWC WWD

MONTANA WELL LOG REPORT

Form No. 603 R2-04

Well ID# SC15-194

This log reports the activities of a licensed Montana well driller and serves as the official record of work done within the borehole and casing and describes the amount of water encountered. **This form is to be completed by the driller and filed with MBMG within 60 days of completion of the work.** Acquiring Water Rights is the well owner's responsibility and is not accomplished by the filing of this report.

Well log information is stored in the Groundwater Information Center at the Montana Bureau of Mines and Geology (Butte) and water right information is stored in the Water Rights Bureau records (Helena).

For fields that are not applicable, enter NA. Record additional information in the REMARKS section.

1. WELL OWNER:
 Name TINTINA ALASKA EXPLORATION, INC
 Mailing address 17 EAST MAIN
WHITE SULPHUR SPRINGS, MT 59645

2. WELL LOCATION: List ¼ from smallest to largest
 _____ ¼ _____ ¼ NE ¼ SW ¼, Section 25
 Township 12N Range 6E County MEAGHER
 Lot _____, Tract/Blk _____ Subdivision Name _____
 Certificate of Survey _____
 Well Address _____
 GPS Yes No
 Latitude N45°45.922 Longitude W110°55.005
 Error as reported by GPS locator (± feet) 9 FT
 Horizontal datum NAD27 WGS84

3. PROPOSED USE: Domestic Stock Irrigation
 Public water supply Monitoring Well
 Geothermal Closed System Open System Reinjection
 Extraction H₂O Temp _____ Number of Wells in System _____
 Other: _____

4. TYPE OF WORK:
 New well Deepen existing well Abandon existing well
 Method: Cable Rotary Other: CORE

5. WELL CONSTRUCTION DETAILS:
Borehole:
 Dia. 6 in. from 0 ft. to 15 ft.
 Dia. 5 in. from 15 ft. to 99 ft.
 Dia. _____ in. from _____ ft. to _____ ft.

Casing:
 Steel: Wall thickness _____ Threaded Welded
 Dia. _____ in. from _____ ft. to _____ ft.
 Dia. _____ in. from _____ ft. to _____ ft.
 Casing Shoe: Yes No

Plastic: Pressure Rating 5.40 lbs. Threaded Welded
 Dia. 1.5 in. from +2 ft. to 60.0 ft.

Perforations/Slotted Pipe:
 Type of perforator used _____
 Size of perforations/slots _____ in. by _____ in.
 _____ no. of perforations/slots from _____ ft. to _____ ft.
 _____ no. of perforations/slots from _____ ft. to _____ ft.

Screens: Yes No
 Material PVC
 Dia. 1.5 Slot size 0.020 from 60.0 ft. to 80.0 ft.
 Dia. _____ Slot size _____ from _____ ft. to _____ ft.

Gravel Packed: Yes No
 Size of gravel 10/20
 Gravel placed from 85.0 ft. to 56.3 ft.

Packer: Yes No
 Type _____ Depth(s) _____

Grout: Material used BENTONITE GROUT
 Depth from 2 ft. to 56.3 ft. OR Continuous feed

6. WELL TEST DATA:
 A well test is required for all wells. (See details on well log report cover.)
 Static water level 25.9 ft. below top of casing or
 Closed-in artesian pressure _____ psi.
 How was test flow measured:
 bucket/stopwatch, weir, flume, flowmeter, etc _____

Yellowstone Controlled Groundwater Area - Water Temperature _____ °F
 AQUIFER TEST DATA FORM ATTACHED

Test - 1 hour minimum
 Drawdown is the amount water level is lowered below static level.
 All depth measurements shall be from the top of the well casing.
 Time of recovery is hours/minutes since pumping stopped.

Air test*
 _____ gpm with drill stem set at _____ ft. for _____ hours
 Time of recovery _____ hrs/min. Recovery water level _____ ft.

OR Bailer test*
 _____ gpm with _____ ft. of drawdown after _____ hours
 Time of recovery _____ hrs/min. Recovery water level _____ ft.

OR Pump test*
 Depth pump set for test _____ ft.
 _____ gpm pump rate with _____ ft. of drawdown after _____ hrs pumping
 Time of recovery _____ hrs/min. Recovery water level _____ ft.

OR Flowing Artesian*
 _____ gpm for _____ hours
 Flow controlled by _____

*During the well test the discharge rate shall be as uniform as possible. This rate may or may not be the sustainable yield of the well. Sustainable yield does not include the reservoir of the well casing.

7. WELL LOG: Record depth(s) that water is encountered.

Depth, Feet		Material: color/rock and type/descriptor (example: blue/shale/hard, or brown/gravel/water, or brown/sand/heaving)
From	To	
<u>0</u>	<u>2</u>	<u>TOP SOIL</u>
<u>2</u>	<u>99</u>	<u>SHALE</u>

ADDITIONAL SHEETS ATTACHED

8. DATE WELL COMPLETED: 3/18/15

9. REMARKS: ARAS ABOVE AND BELOW SAND
GRAVEL WITH COATED BENTONITE PELLETS

10. DRILLER/CONTRACTOR'S CERTIFICATION:
 All work performed and reported in this well log is in compliance with the Montana well construction standards. This report is true to the best of my knowledge.
 Name, firm, or corporation (print) RUVEN DRILLING, INC
 Address P.O. Box 267, CLARKFORK, ID
 Signature [Signature]
 Date 3/25/15 License no. 554/197
 License type: MWC WWC WWD

MONTANA WELL LOG REPORT

Form No. 603 R2-04

Well ID# 3C15-185

This log reports the activities of a licensed Montana well driller and serves as the official record of work done within the borehole and casing and describes the amount of water encountered. This form is to be completed by the driller and filed with MBMG within 60 days of completion of the work. Acquiring Water Rights is the well owner's responsibility and is not accomplished by the filing of this report. Well log information is stored in the Groundwater Information Center at the Montana Bureau of Mines and Geology (Butte) and water right information is stored in the Water Rights Bureau records (Helena). For fields that are not applicable, enter NA. Record additional information in the REMARKS section.

1. WELL OWNER: Name TINTINA ALASKA EXPLORATION, INC Mailing address 17 EAST MAIN WHITE SULPHUR SPRINGS, MT 59645

2. WELL LOCATION: List 1/4 from smallest to largest NE 1/4 NW 1/4, Section 36 Township 2 N Range 6 E County MIBAGEL Latitude N 45 45.922 Longitude W 110 55.005 Error as reported by GPS locator (+/- feet) 9 FT

3. PROPOSED USE: Monitoring Well

4. TYPE OF WORK: New well

5. WELL CONSTRUCTION DETAILS: Borehole: Dia. 6 in. from 0 ft. to 15 ft. Dia. 15 in. from 15 ft. to 99 ft.

Casing: Steel: Wall thickness Threaded Welded Dia. in. from ft. to ft.

Plastic: Pressure Rating 5.40 lbs. Threaded Welded Dia. 1.5 in. from 84.2 ft. to 60.0 ft.

Perforations/Slotted Pipe: Type of perforator used Size of perforations/slots in. by in. no. of perforations/slots from ft. to ft.

Screens: Yes No Material PVC Dia. 1.5 Slot size 0.020 from 60.0 ft. to 60.0 ft.

Gravel Packed: Yes No Size of gravel 10/20 Gravel placed from 56.3 ft. to 85 ft.

Packer: Yes No Type Depth(s)

Grout: Material used Bentonite Grout Depth from ft. to ft. OR Continuous feed

6. WELL TEST DATA: A well test is required for all wells. (See details on well log report cover) Static water level 26 ft. below top of casing or Closed-in artesian pressure psi. How was test flow measured: bucket/stopwatch, weir, flume, flowmeter, etc Yellowstone Controlled Groundwater Area - Water Temperature F

Test - 1 hour minimum Drawdown is the amount water level is lowered below static level. All depth measurements shall be from the top of the well casing. Time of recovery is hours/minutes since pumping stopped.

Air test* gpm with drill stem set at ft. for hours Time of recovery hrs/min. Recovery water level ft.

OR Bailer test* gpm with ft. of drawdown after hours Time of recovery hrs/min. Recovery water level ft.

OR Pump test* Depth pump set for test ft. gpm pump rate with ft. of drawdown after hrs pumping Time of recovery hrs/min. Recovery water level ft.

OR Flowing Artesian* gpm for hours Flow controlled by

*During the well test the discharge rate shall be as uniform as possible. This rate may or may not be the sustainable yield of the well. Sustainable yield does not include the reservoir of the well casing.

7. WELL LOG: Record depth(s) that water is encountered.

Table with columns: Depth, Foot (From, To) and Material (color/rock and type/descriptor). Rows show 0-4 SOIL and 4-99 GRANODIORITE.

ADDITIONAL SHEETS ATTACHED

8. DATE WELL COMPLETED: 3/11/15

9. REMARKS: THE AREA ABOVE AND BELOW SAND SEALED WITH COATED BENTONITE PELLETS

10. DRILLER/CONTRACTOR'S CERTIFICATION: All work performed and reported in this well log is in compliance with the Montana well construction standards. This report is true to the best of my knowledge. Name, firm, or corporation (print) RUBEN DRILLING, INC Address P. O. Box 267, CLARKSVILLE, ID 83811 Signature Date 2/25/15 License no. 559/197 License type: MWC WWWC WWD

Montana Bureau of Mines & Geology The University of Montana 1300 West Park Street Butte, MT 59701

MONTANA WELL LOG REPORT

Form No. 603 R2-04

Well ID# SK15-184

This log reports the activities of a licensed Montana well driller and serves as the official record of work done within the borehole and casing and describes the amount of water encountered. **This form is to be completed by the driller and filed with MBMG within 60 days of completion of the work.** Acquiring Water Rights is the well owner's responsibility and is not accomplished by the filing of this report.

Well log information is stored in the Groundwater Information Center at the Montana Bureau of Mines and Geology (Butte) and water right information is stored in the Water Rights Bureau records (Helena).

For fields that are not applicable, enter NA. Record additional information in the REMARKS section.

1. WELL OWNER:

Name TINTINA ALASKA EXPLORATION, INC
Mailing address 17 EAST MAIN
WHITE SULPHUR SPRINGS, MT 59645

2. WELL LOCATION:

List ¼ from smallest to largest
_____ ¼ _____ ¼ NE ¼ NE ¼, Section 36
Township 20N Range 6E County MEADHER
Lot _____, Tract/Blk _____ Subdivision Name _____
Certificate of Survey _____
Well Address _____
GPS Yes No
Latitude 45° 45.855 Longitude 110° 59.464
Error as reported by GPS locator (\pm feet) 9 FT
Horizontal datum NAD27 WGS84

3. PROPOSED USE:

Domestic Stock Irrigation
 Public water supply Monitoring Well
 Geothermal Closed System Open System Reinjection
 Extraction H₂O Temp _____ Number of Wells in System _____
 Other: _____

4. TYPE OF WORK:

New well Deepen existing well Abandon existing well
Method: Cable Rotary Other: CURB

5. WELL CONSTRUCTION DETAILS:

Borehole:
Dia. 6 in. from 0 ft. to 15 ft.
Dia. 5 in. from 15 ft. to 99 ft.
Dia. _____ in. from _____ ft. to _____ ft.

Casing:
Steel: Wall thickness _____ Threaded Welded
Dia. _____ in. from _____ ft. to _____ ft.
Dia. _____ in. from _____ ft. to _____ ft.
Casing Shoe: Yes No

Plastic: Pressure Rating 5.40 lbs. Threaded Welded
Dia. 1.5 in. from +2 ft. to 55.1 ft.

Perforations/Slotted Pipe:
Type of perforator used _____
Size of perforations/slots _____ in. by _____ in.
_____ no. of perforations/slots from _____ ft. to _____ ft.
_____ no. of perforations/slots from _____ ft. to _____ ft.

Screens: Yes No
Material PVC
Dia. 1.5 Slot size 0.020 from 55.1 ft. to 85.1 ft.
Dia. _____ Slot size _____ from _____ ft. to _____ ft.

Gravel Packed: Yes No
Size of gravel 10/20
Gravel placed from 90.0 ft. to 49.0 ft.

Packer: Yes No
Type _____ Depth(s) _____

Grout: Material used CEMENT
Depth from 3 ft. to 43.6 ft. OR Continuous feed

6. WELL TEST DATA:

A well test is required for all wells. (See details on well log report cover.)
 Static water level _____ ft. below top of casing or
 Closed-in artesian pressure 4 psi.
How was test flow measured:
bucket/stopwatch, weir, flume, flowmeter, etc _____
Yellowstone Controlled Groundwater Area - Water Temperature _____ °F
 AQUIFER TEST DATA FORM ATTACHED

Test - 1 hour minimum

Drawdown is the amount water level is lowered below static level.
All depth measurements shall be from the top of the well casing.
Time of recovery is hours/minutes since pumping stopped.

Air test*
_____ gpm with drill stem set at _____ ft. for _____ hours
Time of recovery _____ hrs/min. Recovery water level _____ ft.

OR Bailor test*

_____ gpm with _____ ft. of drawdown after _____ hours
Time of recovery _____ hrs/min. Recovery water level _____ ft.

OR Pump test*

Depth pump set for test _____ ft.
_____ gpm pump rate with _____ ft. of drawdown after _____ hrs pumping
Time of recovery _____ hrs/min. Recovery water level _____ ft.

OR Flowing Artesian*

5 gpm for 20 hours
Flow controlled by PACKER

*During the well test the discharge rate shall be as uniform as possible. This rate may or may not be the sustainable yield of the well. Sustainable yield does not include the reservoir of the well casing.

7. WELL LOG: Record depth(s) that water is encountered.

Depth, Feet		Material: color/rock and type/descriptor (example: blue/shale/hard, or brown/gravel/water, or brown/sand/heaving)
From	To	
<u>0</u>	<u>10</u>	<u>SOIL</u>
<u>10</u>	<u>99</u>	<u>GRANODIORITE</u>

ADDITIONAL SHEETS ATTACHED

8. DATE WELL COMPLETED: 3/10/15

9. REMARKS: AREAS ABOVE AND BELOW SAND SEALED WITH COATED BENTONITE PELLETS

10. DRILLER/CONTRACTOR'S CERTIFICATION:

All work performed and reported in this well log is in compliance with the Montana well construction standards. This report is true to the best of my knowledge.

Name, firm, or corporation (print) RUBEN DRILLING, INC
Address P.O. Box 267, CLARK FORK, 10 83511
Signature [Signature]
Date 3/25/15 License no. 559/197
License type: MWC WWC WWD

Montana Bureau of Mines & Geology
The University of Montana
1300 West Park Street
Butte, MT 59701

APPENDIX D

AQUIFER TEST ANALYSES

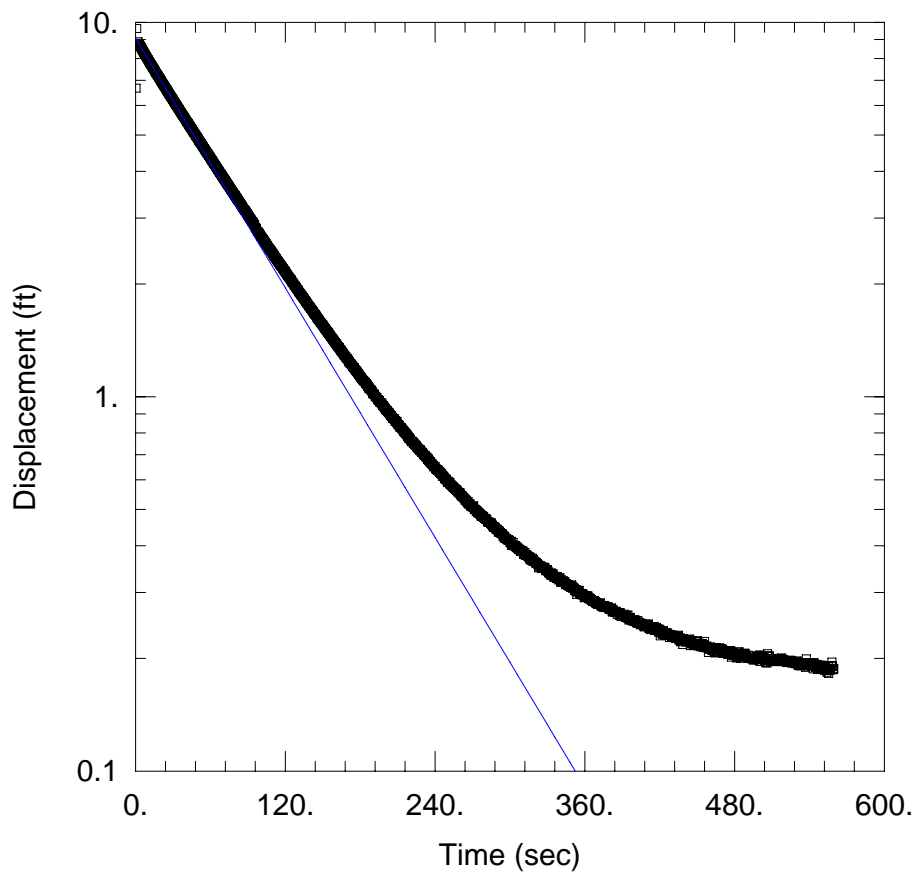

WELL TEST ANALYSIS

Data Set: K:\...\MW-3 slug test2.aqt

Date: 08/24/15

Time: 16:09:46

AQUIFER DATA

Saturated Thickness: 27. ft

Anisotropy Ratio (K_z/K_r): 1.

WELL DATA (MW-3)

Initial Displacement: 8.7 ft

Static Water Column Height: 278.3 ft

Total Well Penetration Depth: 278. ft

Screen Length: 20. ft

Casing Radius: 0.083 ft

Well Radius: 0.083 ft

SOLUTION

Aquifer Model: Confined

Solution Method: Bower-Rice

$K = 1.137$ ft/day

$y_0 = 9.071$ ft

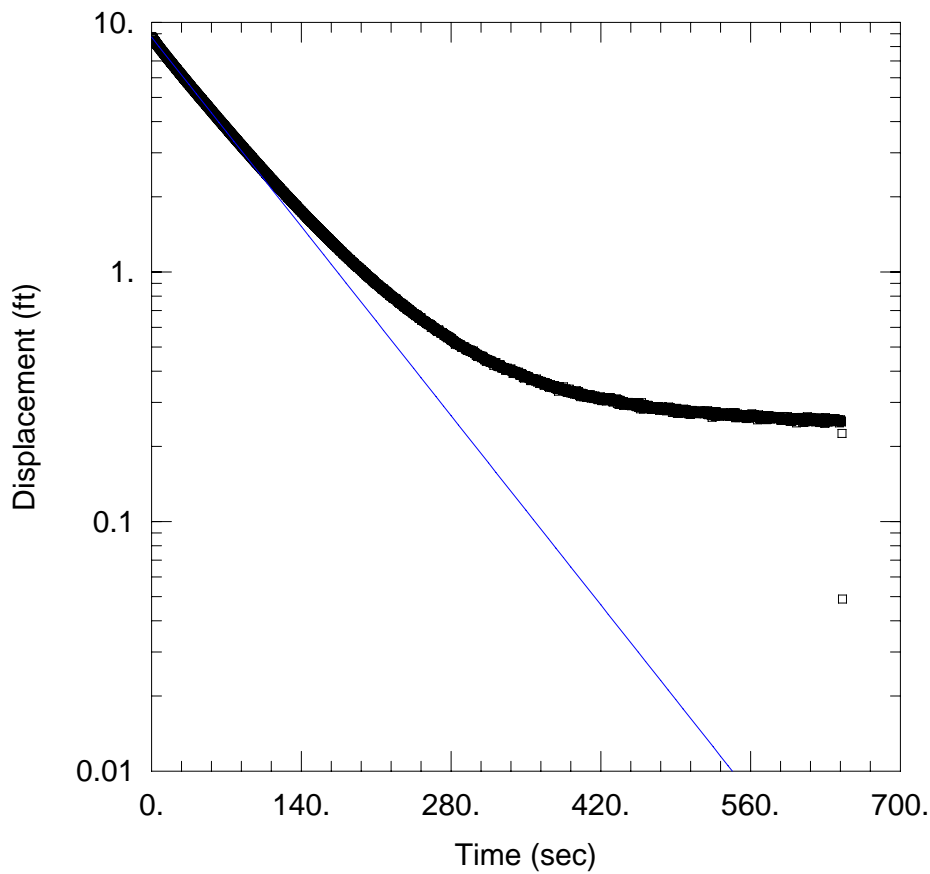

WELL TEST ANALYSIS

Data Set: K:\...\MW-3 slug test.aqt
 Date: 08/24/15

Time: 16:09:24

AQUIFER DATA

Saturated Thickness: 27. ft

Anisotropy Ratio (K_z/K_r): 1.

WELL DATA (MW-3)

Initial Displacement: 8.7 ft
 Total Well Penetration Depth: 278. ft
 Casing Radius: 0.083 ft

Static Water Column Height: 278.3 ft
 Screen Length: 20. ft
 Well Radius: 0.083 ft

SOLUTION

Aquifer Model: Confined

Solution Method: Hvorslev

$K = 1.146$ ft/day

$y_0 = 8.718$ ft

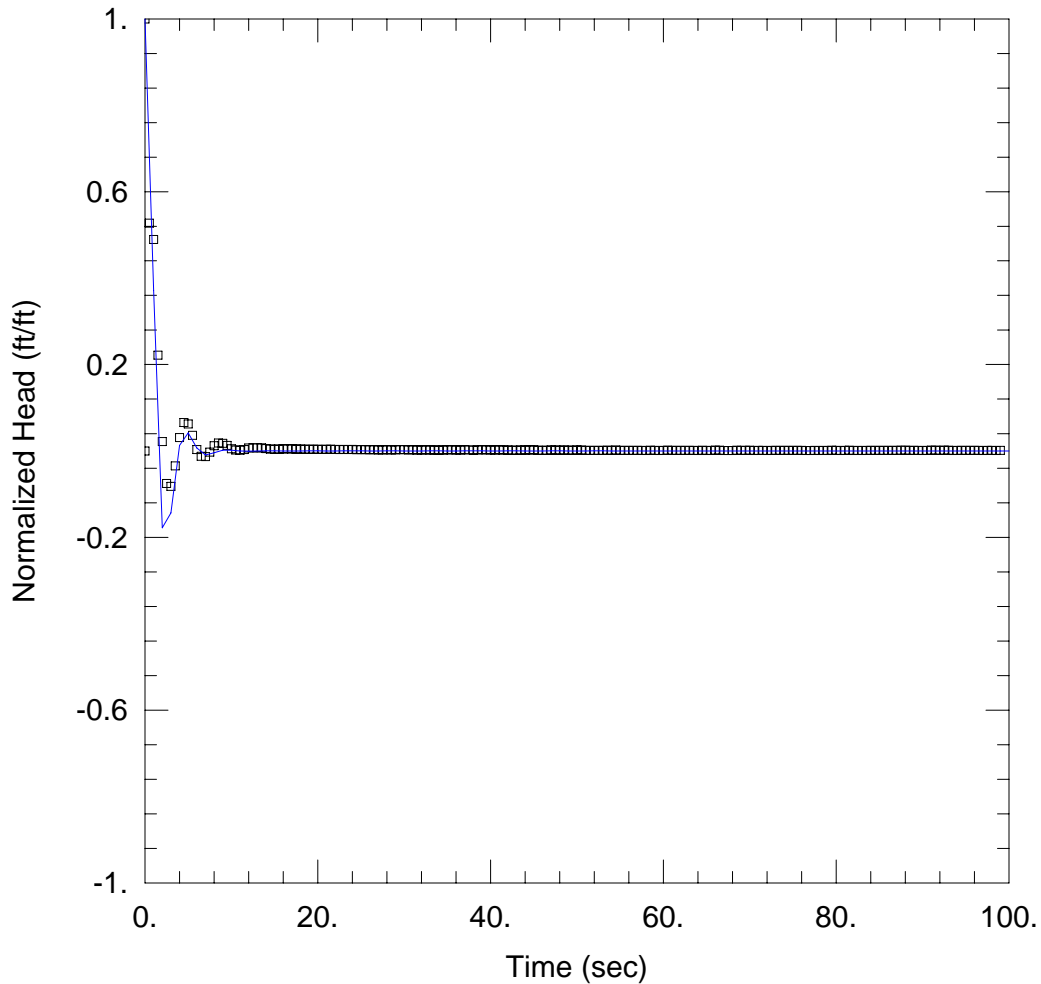

WELL TEST ANALYSIS

Data Set: K:\...\MW-4A_Test1.aqt
 Date: 08/24/15

Time: 16:09:58

AQUIFER DATA

Saturated Thickness: 19.4 ft

Anisotropy Ratio (Kz/Kr): 1.

WELL DATA (MW-4A)

Initial Displacement: 3.8 ft
 Total Well Penetration Depth: 19.4 ft
 Casing Radius: 0.083 ft

Static Water Column Height: 19.4 ft
 Screen Length: 10. ft
 Well Radius: 0.083 ft

SOLUTION

Aquifer Model: Unconfined

Solution Method: Springer-Gelhar

K = 208.3 ft/day

Le = 14.6 ft

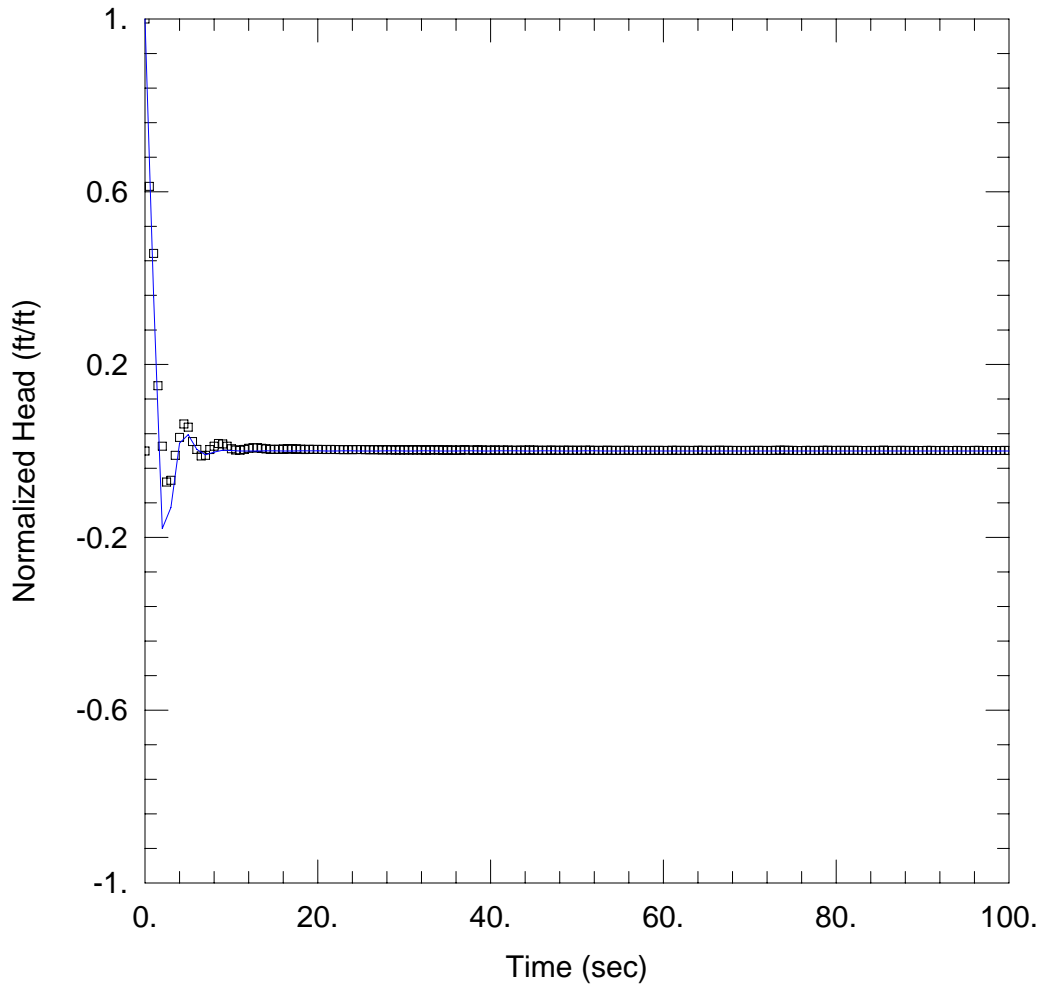

WELL TEST ANALYSIS

Data Set: K:\...\MW-4A_Test2.aqt
 Date: 08/24/15

Time: 16:10:07

AQUIFER DATA

Saturated Thickness: 19.4 ft

Anisotropy Ratio (K_z/K_r): 1.

WELL DATA (MW-4A)

Initial Displacement: 4.8 ft
 Total Well Penetration Depth: 19.4 ft
 Casing Radius: 0.083 ft

Static Water Column Height: 19.4 ft
 Screen Length: 10. ft
 Well Radius: 0.083 ft

SOLUTION

Aquifer Model: Unconfined

Solution Method: Springer-Gelhar

$K = 209.9$ ft/day

$L_e = 14.01$ ft

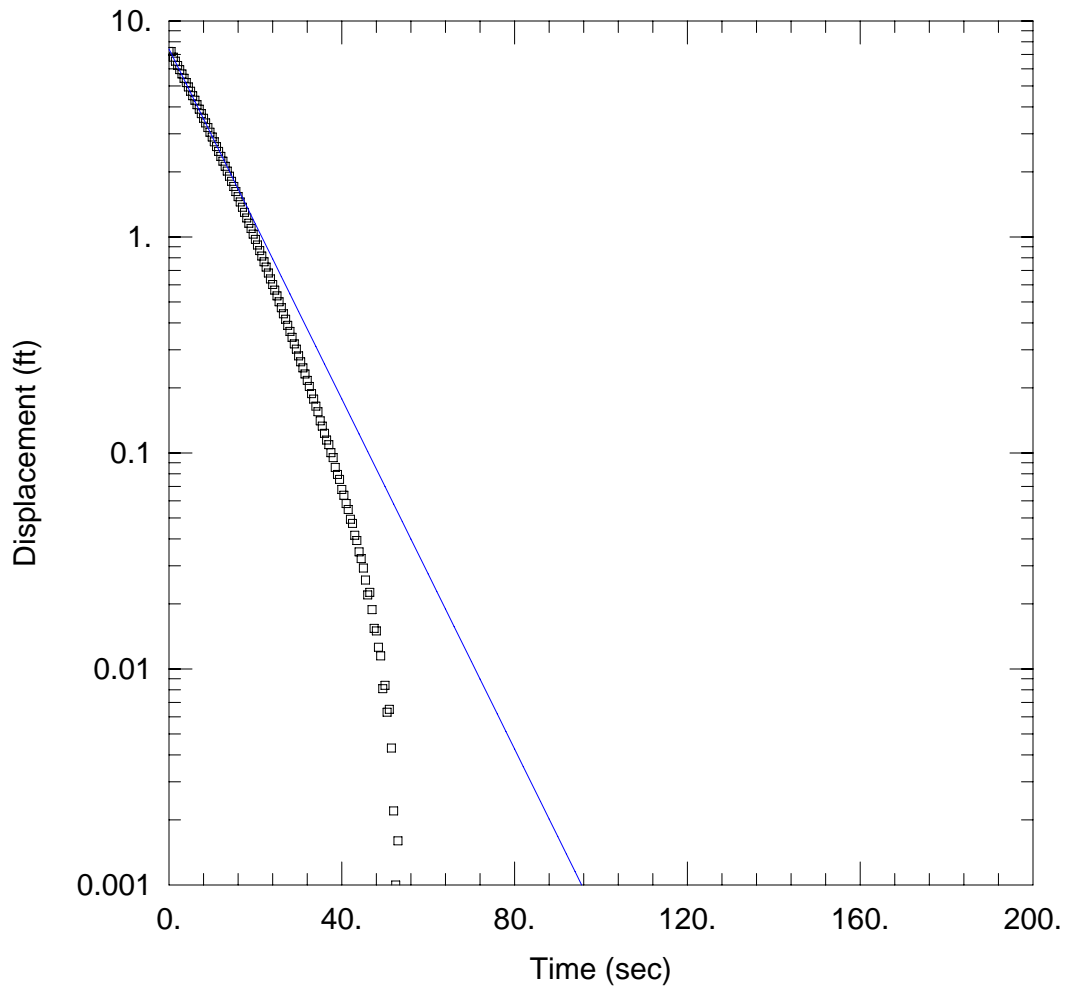

WELL TEST ANALYSIS

Data Set: K:\...\MW_6B_Slug1_Hvorslev.aqt

Date: 03/01/17

Time: 14:44:43

PROJECT INFORMATION

Company: Hydrometrics, Inc.

Client: TR

Location: WSS

Test Well: MW-6B

Test Date: 8/22/16

AQUIFER DATA

Saturated Thickness: 38. ft

Anisotropy Ratio (Kz/Kr): 1.

WELL DATA (MW-6B)

Initial Displacement: 7.22 ft

Static Water Column Height: 38. ft

Total Well Penetration Depth: 37.86 ft

Screen Length: 10. ft

Casing Radius: 0.083 ft

Well Radius: 0.083 ft

SOLUTION

Aquifer Model: Unconfined

Solution Method: Hvorslev

K = 13.3 ft/day

y0 = 7.417 ft

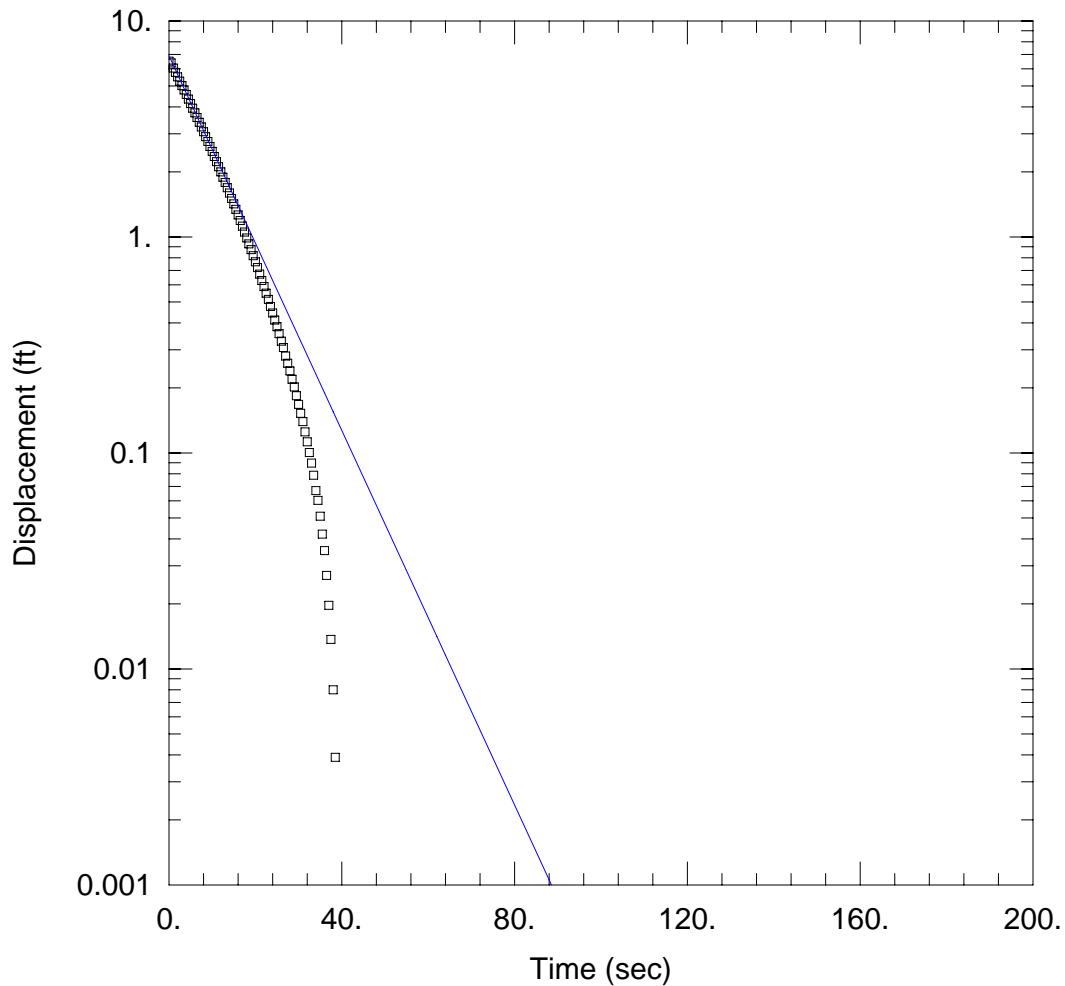

WELL TEST ANALYSIS

Data Set: K:\...\MW_6B_Slug2_Hvorslev.aqt

Date: 03/01/17

Time: 14:45:24

PROJECT INFORMATION

Company: Hydrometrics, Inc.

Client: TR

Location: WSS

Test Well: MW-6B

Test Date: 8/22/16

AQUIFER DATA

Saturated Thickness: 38. ft

Anisotropy Ratio (Kz/Kr): 1.

WELL DATA (MW-6B)

Initial Displacement: 6.51 ft

Static Water Column Height: 38. ft

Total Well Penetration Depth: 37.86 ft

Screen Length: 10. ft

Casing Radius: 0.083 ft

Well Radius: 0.083 ft

SOLUTION

Aquifer Model: Unconfined

Solution Method: Hvorslev

K = 14.24 ft/day

y0 = 6.901 ft

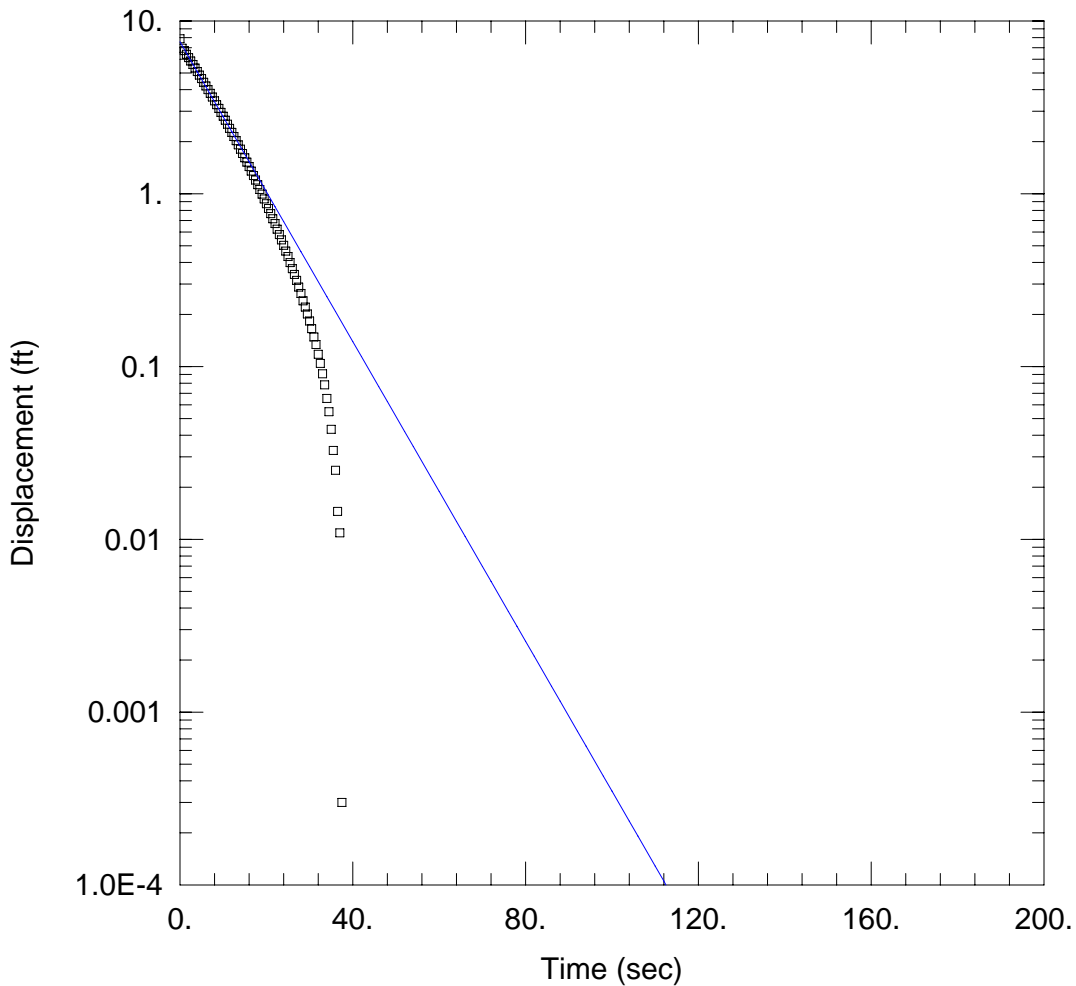

WELL TEST ANALYSIS

Data Set: K:\...\MW_6B_Slug3_Hvorslev.aqt

Date: 03/01/17

Time: 14:45:47

PROJECT INFORMATION

Company: Hydrometrics, Inc.

Client: TR

Location: WSS

Test Well: MW-6B

Test Date: 8/22/16

AQUIFER DATA

Saturated Thickness: 38. ft

Anisotropy Ratio (K_z/K_r): 1.

WELL DATA (MW-6B)

Initial Displacement: 7.88 ft

Static Water Column Height: 38. ft

Total Well Penetration Depth: 37.86 ft

Screen Length: 10. ft

Casing Radius: 0.083 ft

Well Radius: 0.083 ft

SOLUTION

Aquifer Model: Unconfined

Solution Method: Hvorslev

$K = 14.24$ ft/day

$y_0 = 7.566$ ft

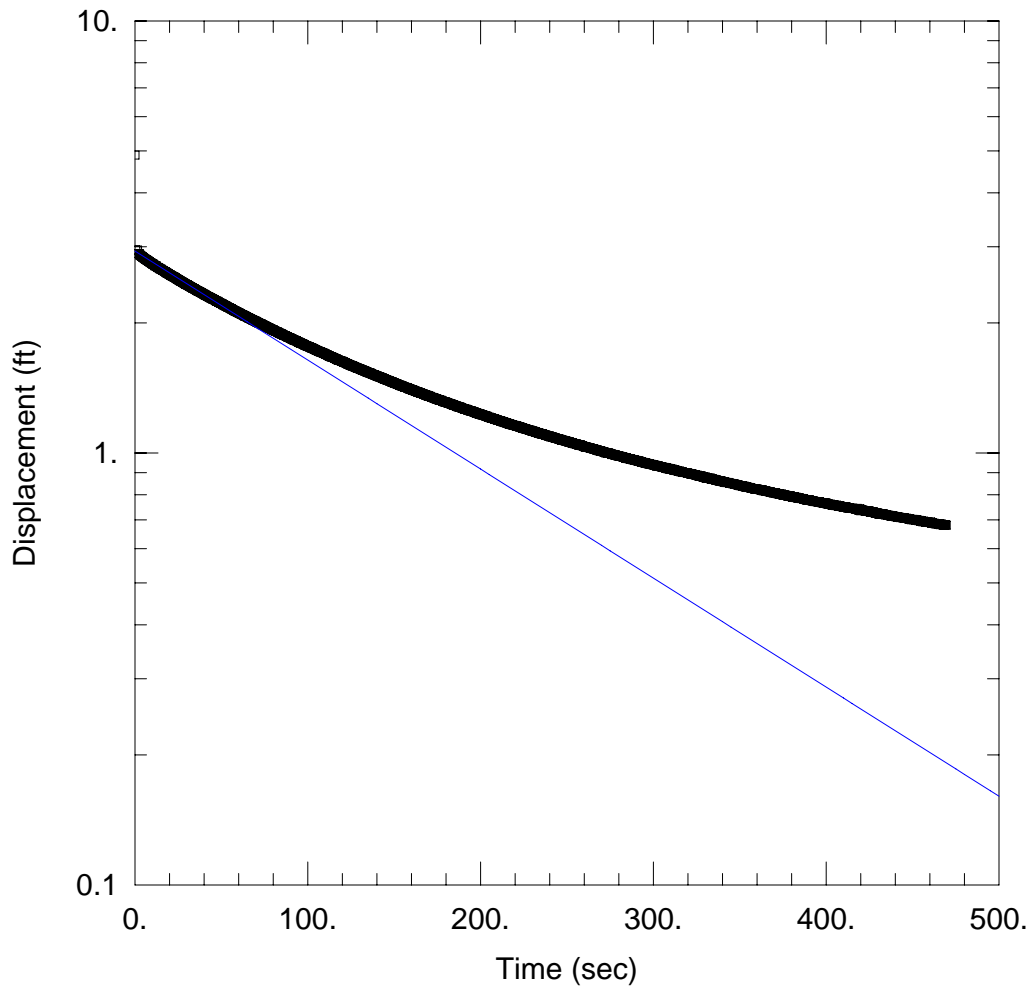

WELL TEST ANALYSIS

Data Set: K:\...\MW_7_Hvorslev.aqt
 Date: 03/01/17

Time: 14:46:15

PROJECT INFORMATION

Company: Hydrometrics, Inc.
 Client: TR
 Location: WSS
 Test Well: MW-7
 Test Date: 8/22/16

AQUIFER DATA

Saturated Thickness: 18. ft

Anisotropy Ratio (K_z/K_r): 1.

WELL DATA (MW-7)

Initial Displacement: 4.89 ft
 Total Well Penetration Depth: 18.18 ft
 Casing Radius: 0.083 ft

Static Water Column Height: 18. ft
 Screen Length: 10. ft
 Well Radius: 0.083 ft

SOLUTION

Aquifer Model: Unconfined
 K = 0.9486 ft/day

Solution Method: Hvorslev
 $y_0 =$ 2.934 ft

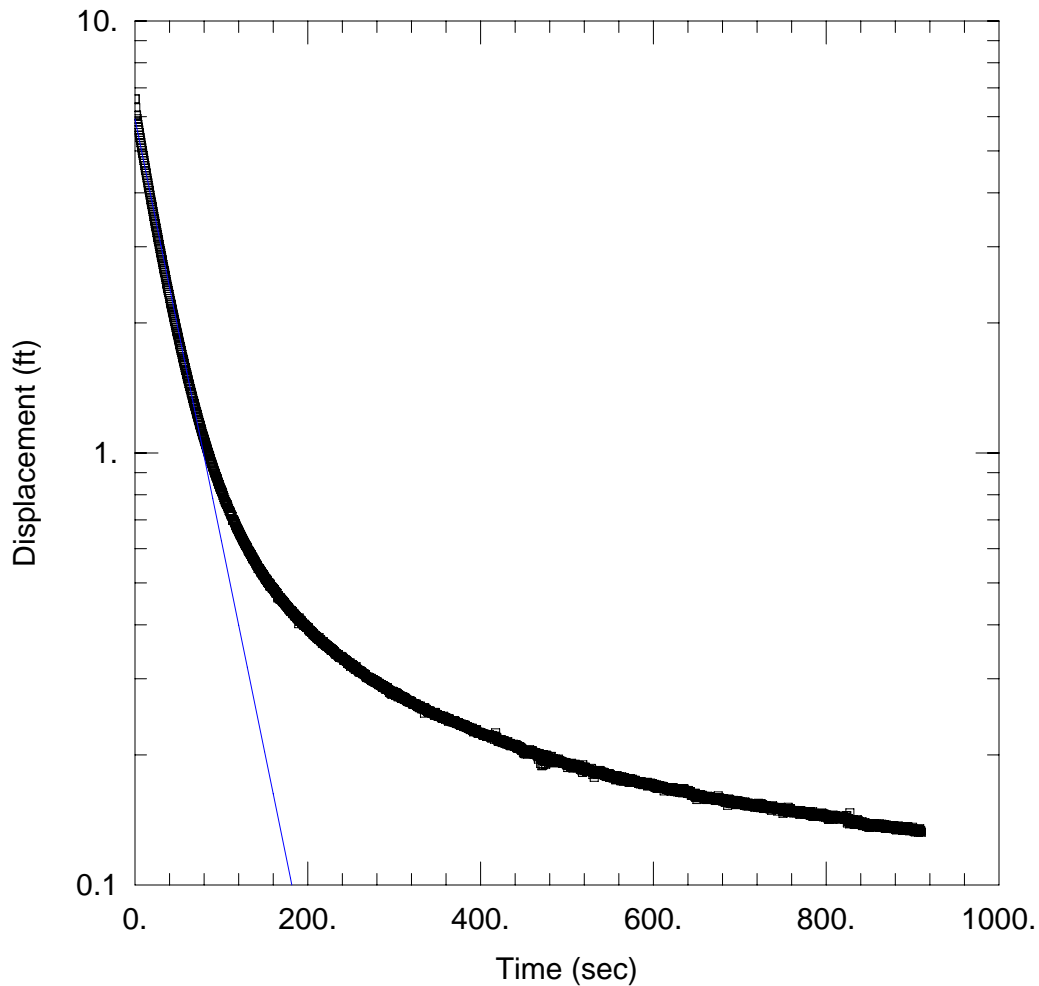

WELL TEST ANALYSIS

Data Set: K:\...\MW_8_Slug1_Hvorslev.aqt

Date: 03/01/17

Time: 14:46:41

PROJECT INFORMATION

Company: Hydrometrics, Inc.

Client: TR

Location: WSS

Test Well: MW-8

Test Date: 8/22/16

AQUIFER DATA

Saturated Thickness: 50. ft

Anisotropy Ratio (K_z/K_r): 1.

WELL DATA (MW-8)

Initial Displacement: 6.6 ft

Static Water Column Height: 50. ft

Total Well Penetration Depth: 50.4 ft

Screen Length: 10. ft

Casing Radius: 0.083 ft

Well Radius: 0.083 ft

SOLUTION

Aquifer Model: Unconfined

Solution Method: Hvorslev

$K = 3.67$ ft/day

$y_0 = 5.932$ ft

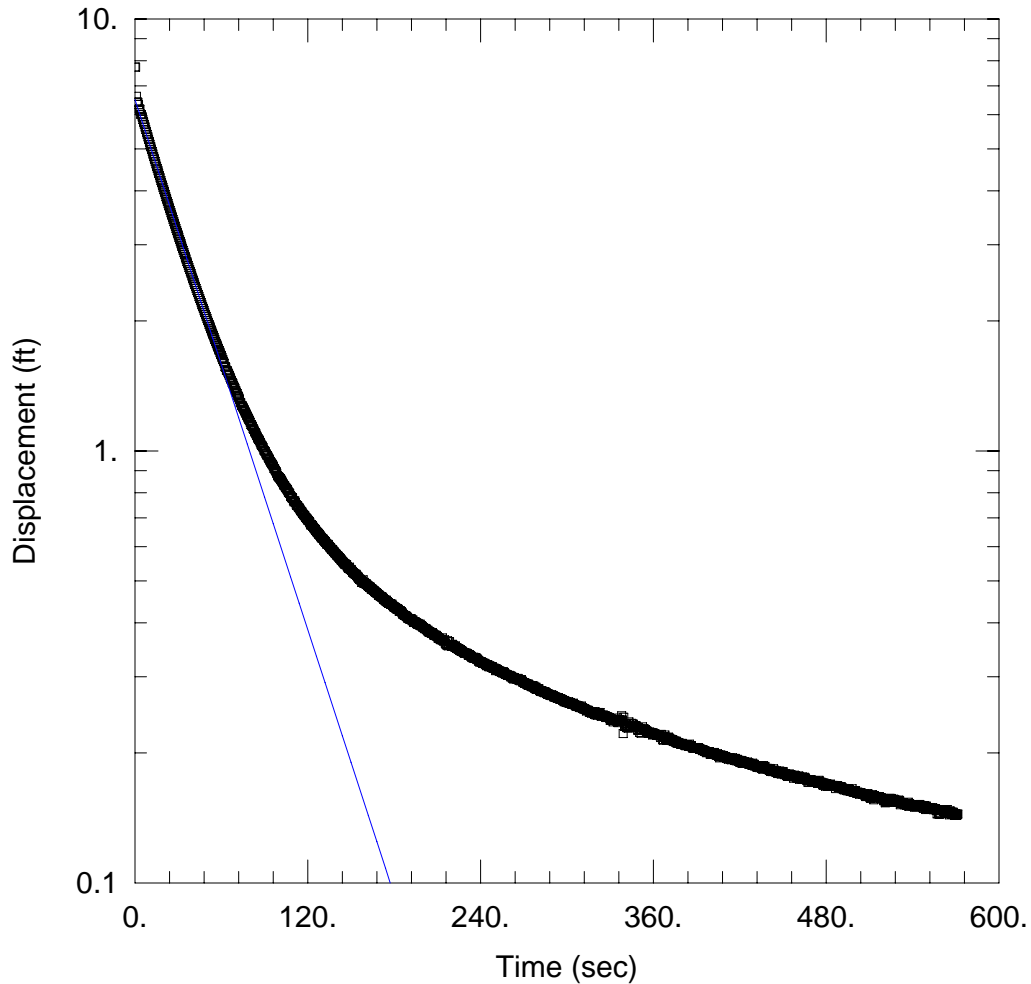

WELL TEST ANALYSIS

Data Set: K:\...\MW_8_Slug2_Hvorslev.aqt
 Date: 03/01/17

Time: 14:47:16

PROJECT INFORMATION

Company: Hydrometrics, Inc.
 Client: TR
 Location: WSS
 Test Well: MW-8
 Test Date: 8/22/16

AQUIFER DATA

Saturated Thickness: 50. ft

Anisotropy Ratio (Kz/Kr): 1.

WELL DATA (MW-8)

Initial Displacement: 7.74 ft
 Total Well Penetration Depth: 50.4 ft
 Casing Radius: 0.083 ft

Static Water Column Height: 50. ft
 Screen Length: 10. ft
 Well Radius: 0.083 ft

SOLUTION

Aquifer Model: Unconfined
 K = 3.843 ft/day

Solution Method: Hvorslev
 y0 = 6.505 ft

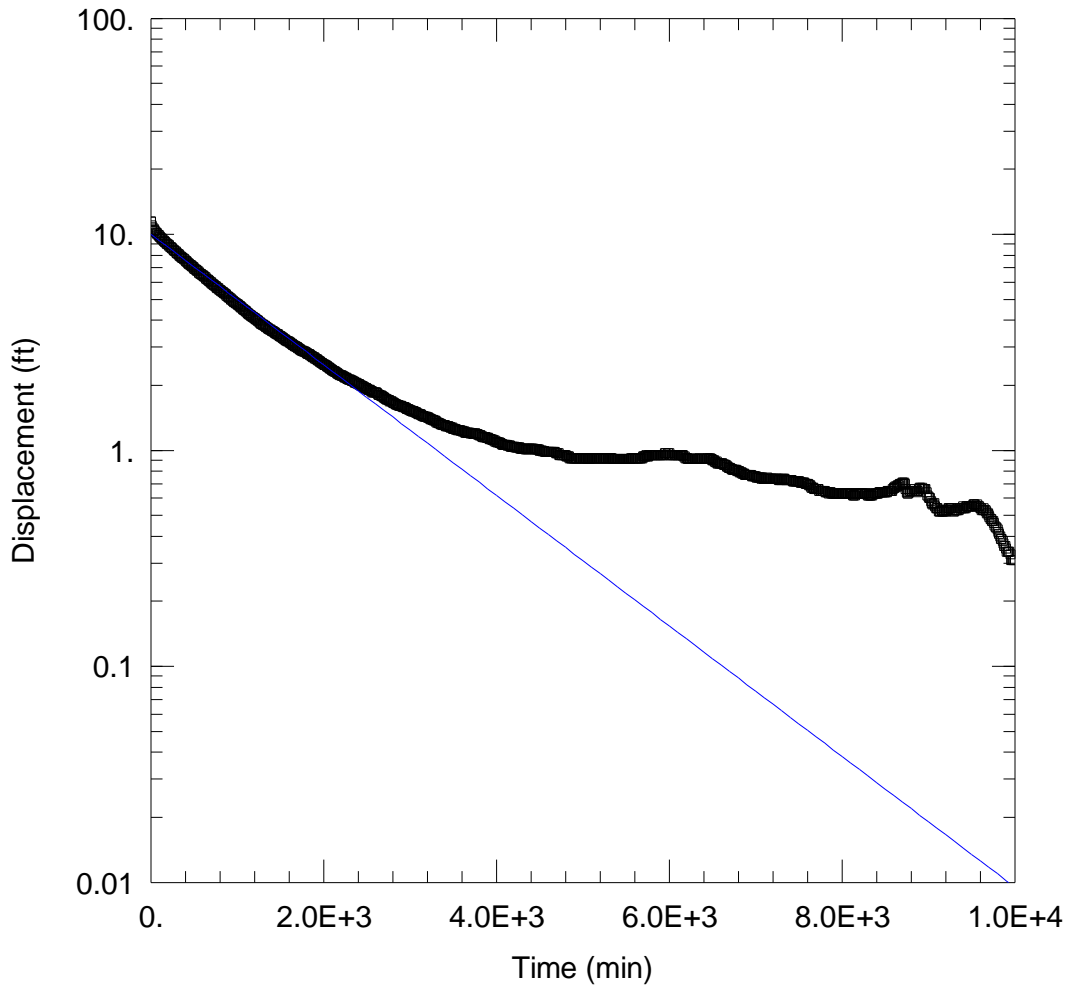

WELL TEST ANALYSIS

Data Set: K:\...\MW-10_BouwerRice.aqt
 Date: 05/20/16

Time: 11:54:15

PROJECT INFORMATION

Company: Hydrometrics
 Project: 11048
 Test Well: MW-10
 Test Date: Forward

AQUIFER DATA

Saturated Thickness: 11.47 ft

Anisotropy Ratio (K_z/K_r): 1.

WELL DATA (MW-10)

Initial Displacement: 11.47 ft
 Total Well Penetration Depth: 13.4 ft
 Casing Radius: 0.0833 ft

Static Water Column Height: 11.47 ft
 Screen Length: 13.4 ft
 Well Radius: 0.0833 ft

SOLUTION

Aquifer Model: Confined

Solution Method: Bouwer-Rice

$K = 0.001022$ ft/day

$y_0 = 10.01$ ft

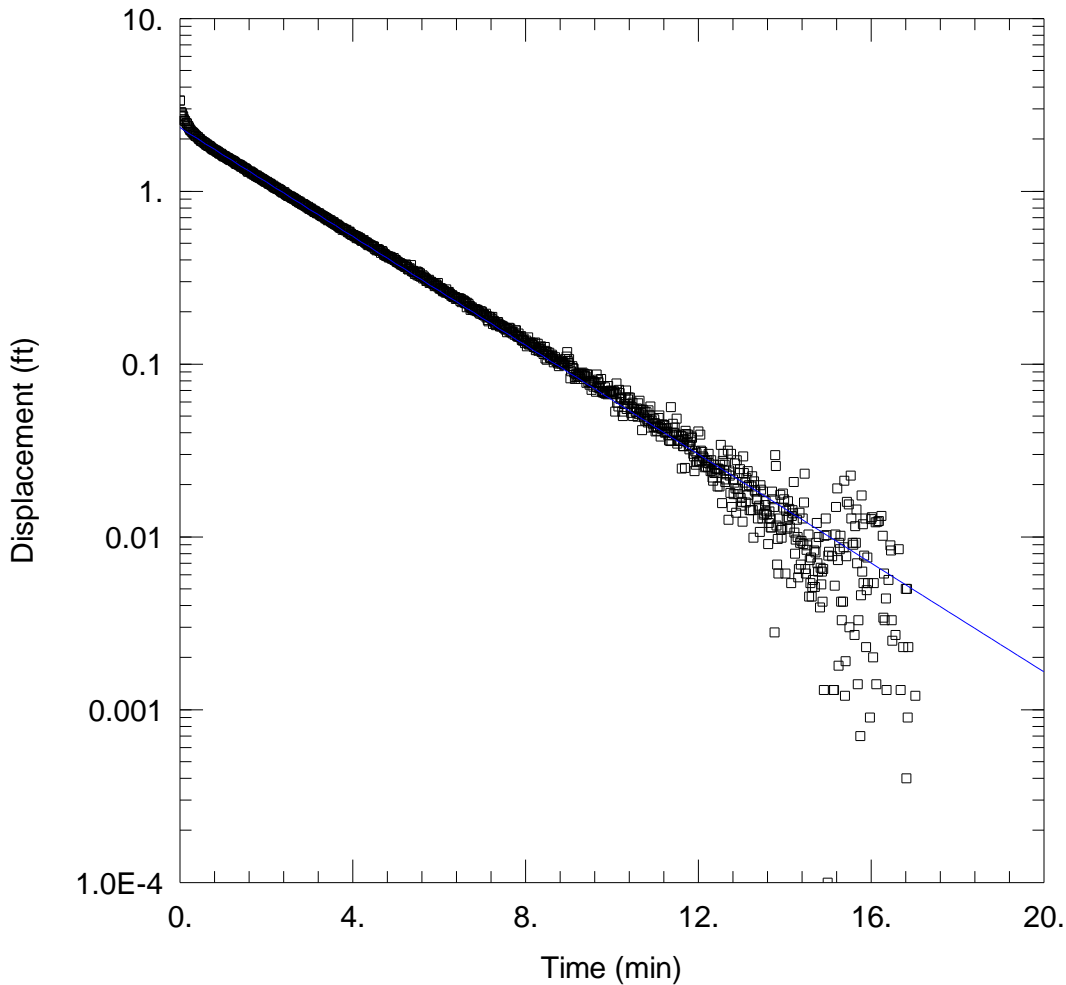

WELL TEST ANALYSIS

Data Set: K:\...\MW_11_Bouwer_Rice.aqt

Date: 05/20/16

Time: 11:55:43

PROJECT INFORMATION

Company: Hydrometrics

Project: 11048

Test Well: MW-11

Test Date: Forward

AQUIFER DATA

Saturated Thickness: 30. ft

Anisotropy Ratio (Kz/Kr): 1.

WELL DATA (MW-11)

Initial Displacement: 3.355 ft

Static Water Column Height: 37.8 ft

Total Well Penetration Depth: 37.8 ft

Screen Length: 20. ft

Casing Radius: 0.0833 ft

Well Radius: 0.08333 ft

SOLUTION

Aquifer Model: Confined

Solution Method: Bouwer-Rice

K = 0.4275 ft/day

y0 = 2.328 ft

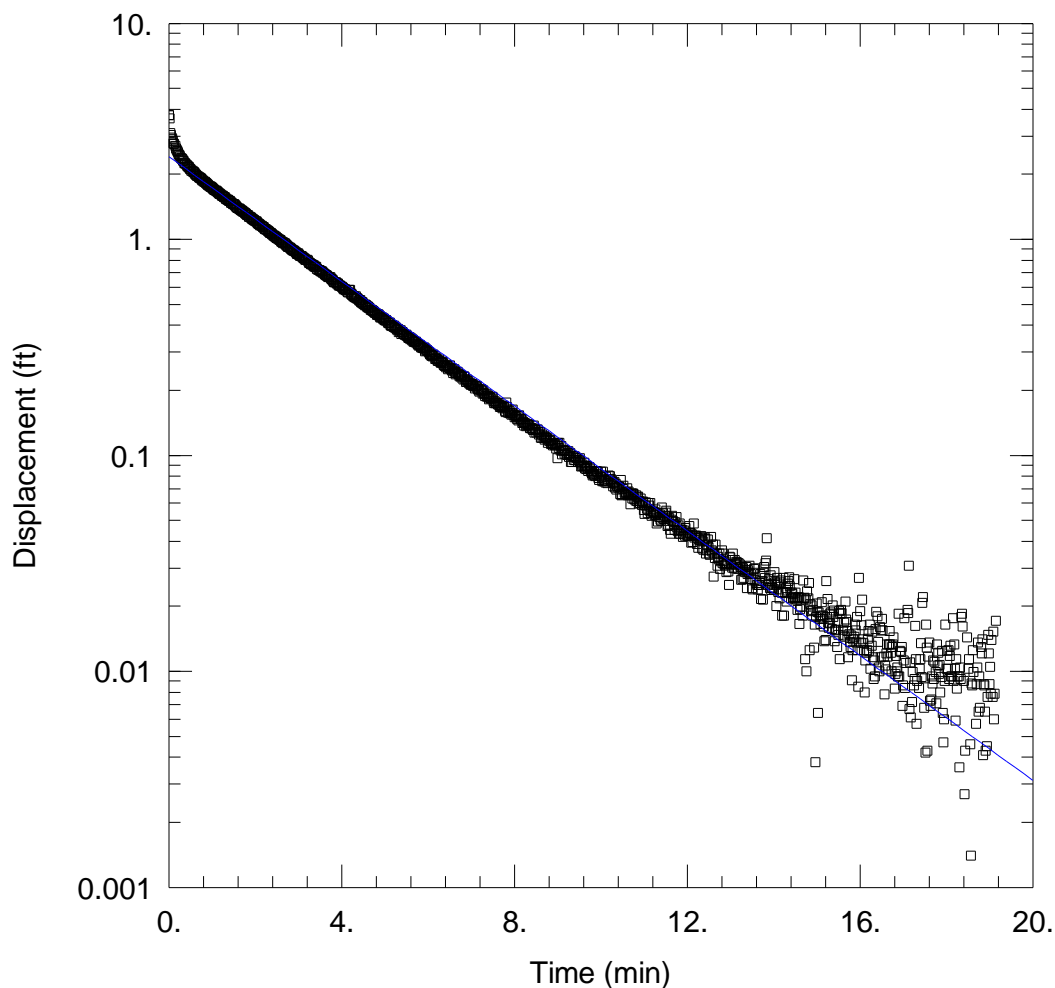

WELL TEST ANALYSIS

Data Set: K:\...\MW_11_Bouwer_Rice.aqt

Date: 05/20/16

Time: 11:56:16

PROJECT INFORMATION

Company: Hydrometrics

Project: 11048

Test Well: MW-11

Test Date: Forward

AQUIFER DATA

Saturated Thickness: 30. ft

Anisotropy Ratio (K_z/K_r): 1.

WELL DATA (MW-11)

Initial Displacement: 3.753 ft

Static Water Column Height: 37.8 ft

Total Well Penetration Depth: 37.8 ft

Screen Length: 20. ft

Casing Radius: 0.0833 ft

Well Radius: 0.08333 ft

SOLUTION

Aquifer Model: Confined

Solution Method: Bouwer-Rice

$K = 0.392$ ft/day

$y_0 = 2.415$ ft

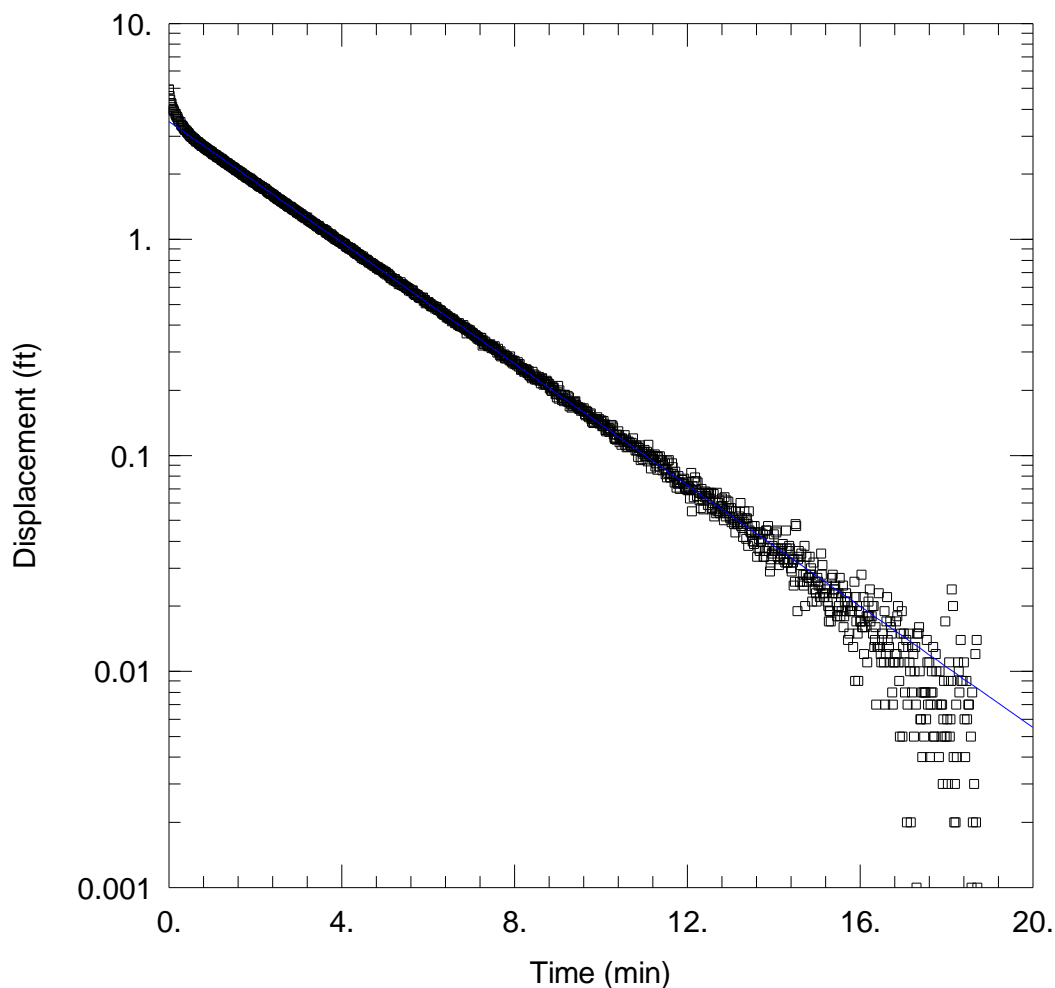

WELL TEST ANALYSIS

Data Set: K:\...\MW_11_BouwerRice.aqt

Date: 05/20/16

Time: 11:54:59

PROJECT INFORMATION

Company: Hydrometrics

Project: 11048

Test Well: MW-11

Test Date: Forward

AQUIFER DATA

Saturated Thickness: 30. ft

Anisotropy Ratio (K_z/K_r): 1.

WELL DATA (MW-11)

Initial Displacement: 4.948 ft

Static Water Column Height: 37.8 ft

Total Well Penetration Depth: 37.8 ft

Screen Length: 20. ft

Casing Radius: 0.0833 ft

Well Radius: 0.08333 ft

SOLUTION

Aquifer Model: Confined

Solution Method: Bouwer-Rice

$K = 0.3809$ ft/day

$y_0 = 3.519$ ft

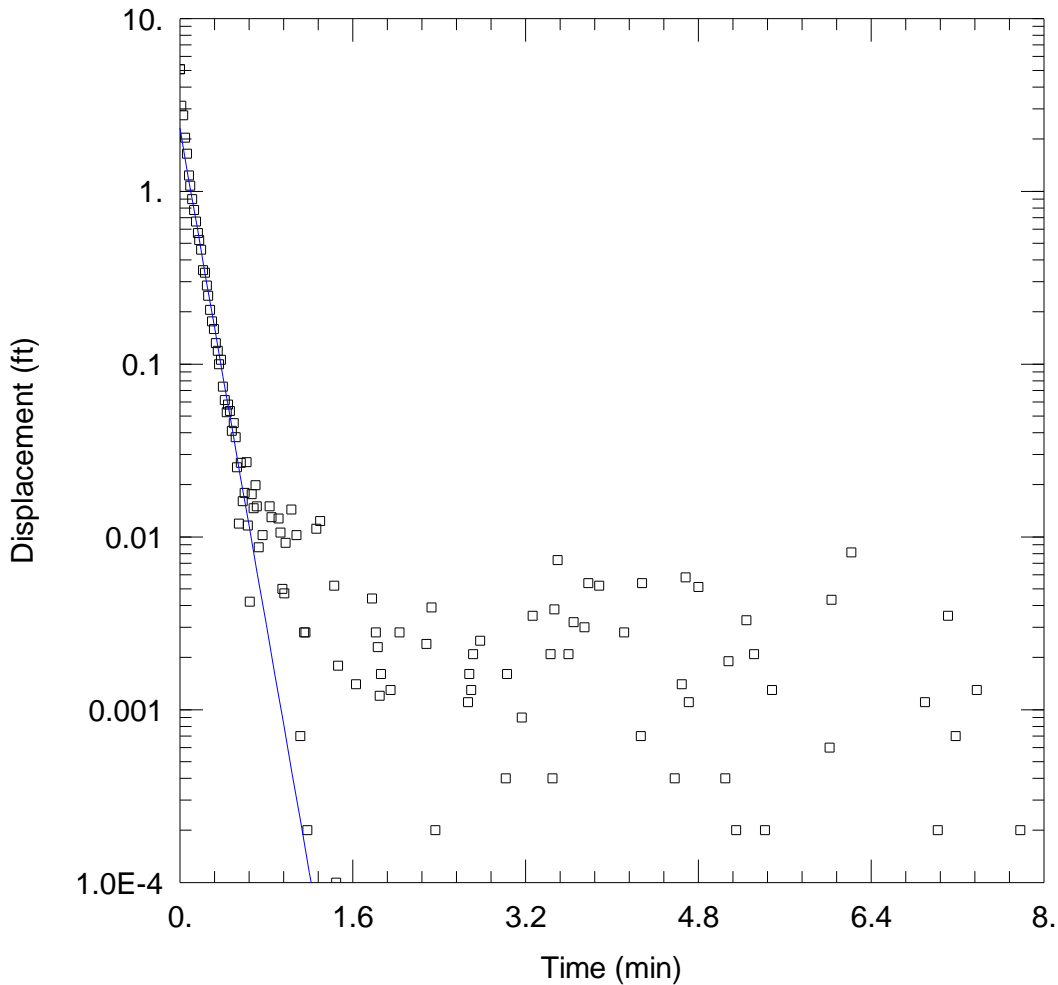

WELL TEST ANALYSIS

Data Set: K:\...\MW_12_Bower_Rice.aqt

Date: 05/20/16

Time: 12:02:43

PROJECT INFORMATION

Company: Hydrometrics

Project: 11048

Test Well: MW-12

Test Date: Forward

AQUIFER DATA

Saturated Thickness: 20. ft

Anisotropy Ratio (Kz/Kr): 1.

WELL DATA (MW-12)

Initial Displacement: 5.095 ft

Static Water Column Height: 32.24 ft

Total Well Penetration Depth: 32.24 ft

Screen Length: 20. ft

Casing Radius: 0.0833 ft

Well Radius: 0.2 ft

SOLUTION

Aquifer Model: Confined

Solution Method: Bower-Rice

K = 7.949 ft/day

y0 = 2.308 ft

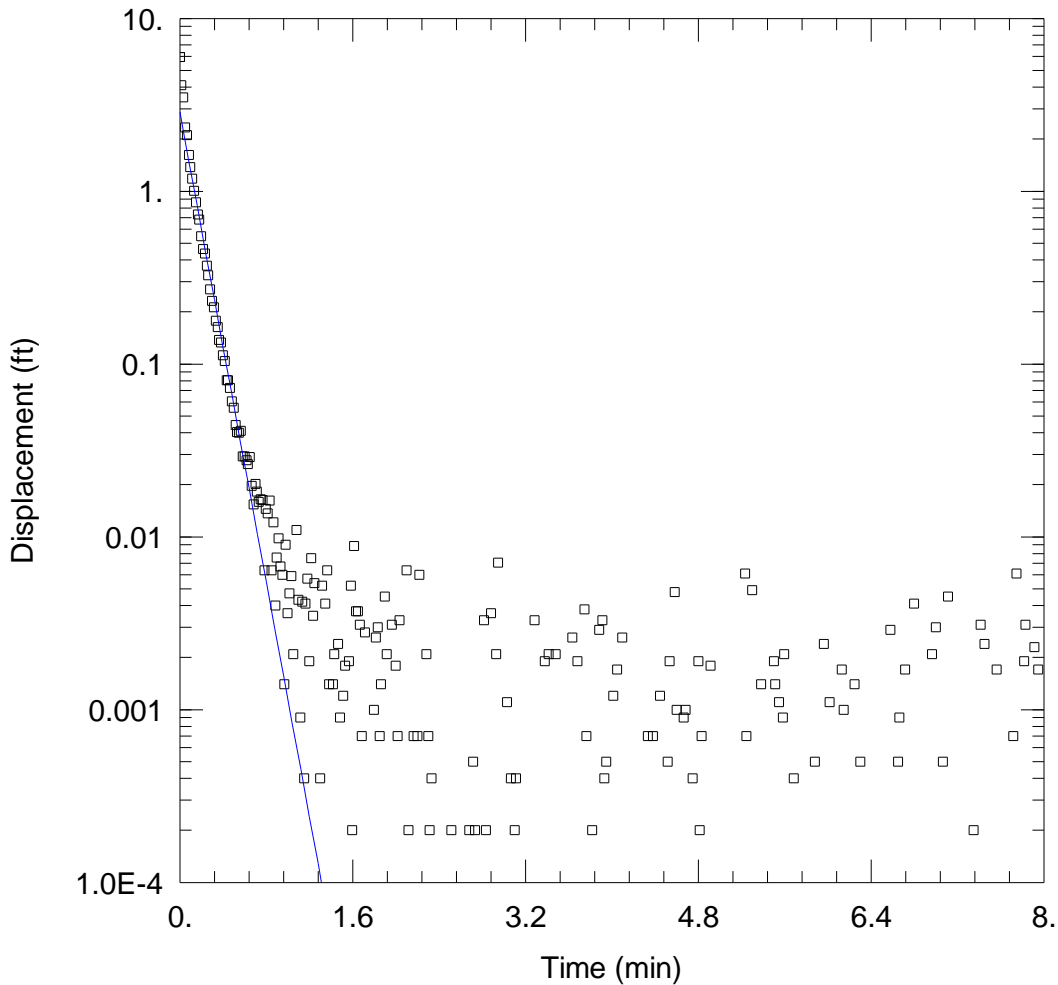

WELL TEST ANALYSIS

Data Set: K:\...\MW_12_Bower_Rice.aqt

Date: 05/20/16

Time: 12:03:30

PROJECT INFORMATION

Company: Hydrometrics

Project: 11048

Test Well: MW-12

Test Date: Forward

AQUIFER DATA

Saturated Thickness: 30. ft

Anisotropy Ratio (K_z/K_r): 1.

WELL DATA (MW-12)

Initial Displacement: 5.95 ft

Static Water Column Height: 32.24 ft

Total Well Penetration Depth: 32.24 ft

Screen Length: 20. ft

Casing Radius: 0.0833 ft

Well Radius: 0.0833 ft

SOLUTION

Aquifer Model: Confined

Solution Method: Bower-Rice

$K =$ 9.028 ft/day

$y_0 =$ 2.877 ft

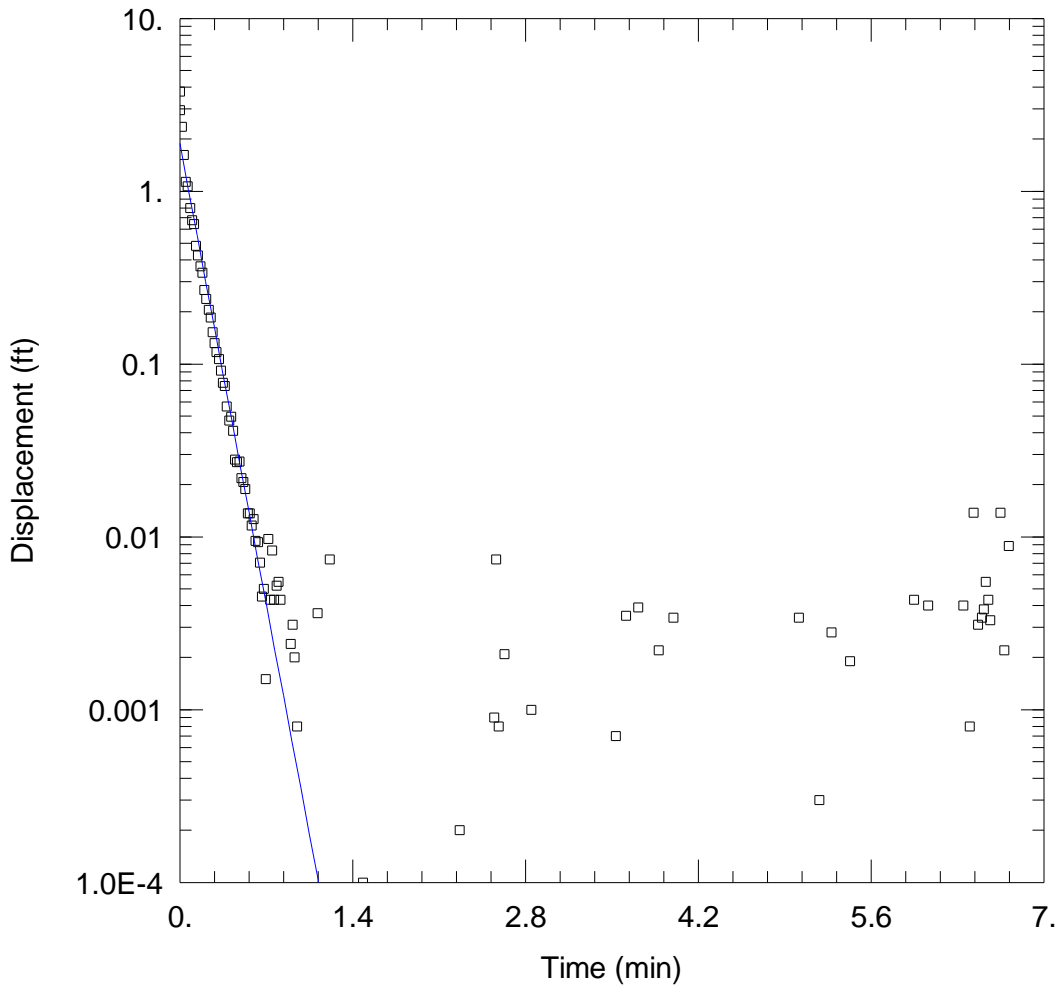

WELL TEST ANALYSIS

Data Set: K:\...\MW_12_BouwerRice.aqt

Date: 05/20/16

Time: 12:04:07

PROJECT INFORMATION

Company: Hydrometrics

Project: 11048

Test Well: MW-12

Test Date: Forward

AQUIFER DATA

Saturated Thickness: 30. ft

Anisotropy Ratio (Kz/Kr): 1.

WELL DATA (MW-12)

Initial Displacement: 3.762 ft

Static Water Column Height: 32.24 ft

Total Well Penetration Depth: 32.24 ft

Screen Length: 20. ft

Casing Radius: 0.0833 ft

Well Radius: 0.0833 ft

SOLUTION

Aquifer Model: Confined

Solution Method: Bouwer-Rice

K = 10.11 ft/day

y0 = 1.881 ft

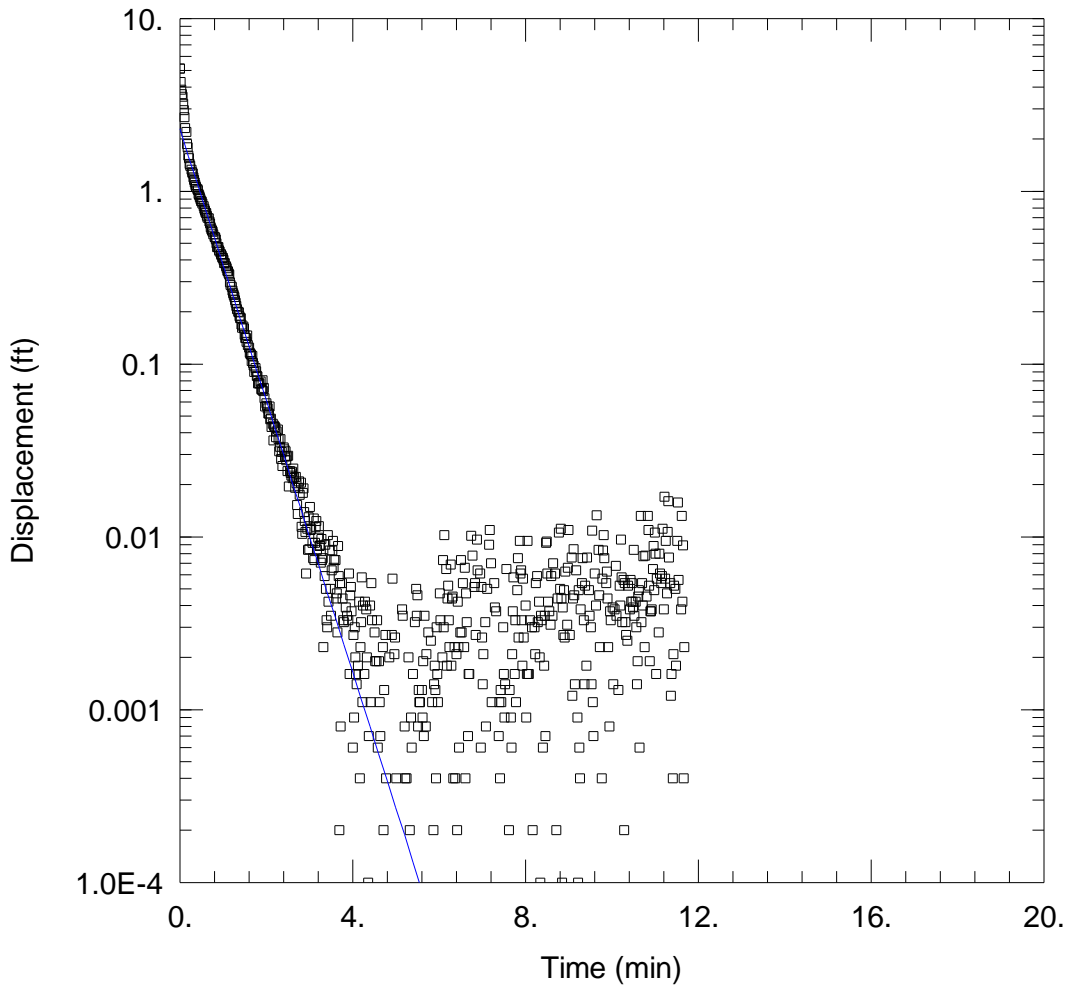

WELL TEST ANALYSIS

Data Set: K:\...\MW-13_Bouwer_Rice.aqt

Date: 05/20/16

Time: 12:07:09

PROJECT INFORMATION

Company: Hydrometrics

Project: 11048

Test Well: MW-13

Test Date: Forward

AQUIFER DATA

Saturated Thickness: 20. ft

Anisotropy Ratio (K_z/K_r): 1.

WELL DATA (MW-13)

Initial Displacement: 5.129 ft

Static Water Column Height: 20. ft

Total Well Penetration Depth: 20. ft

Screen Length: 20. ft

Casing Radius: 0.0833 ft

Well Radius: 0.0833 ft

SOLUTION

Aquifer Model: Unconfined

Solution Method: Bouwer-Rice

$K = 1.943$ ft/day

$y_0 = 2.294$ ft

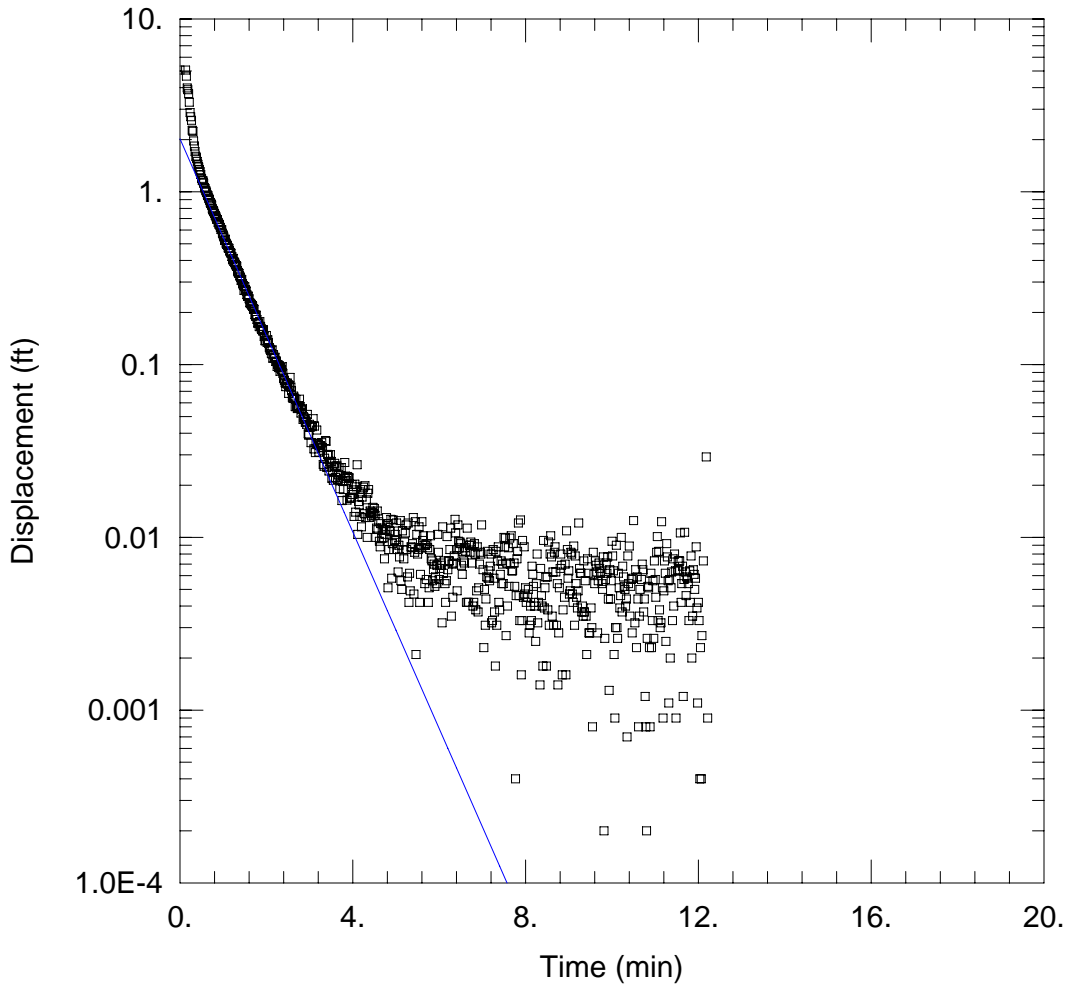

WELL TEST ANALYSIS

Data Set: K:\...\MW-13_BouwerRice.aqt
 Date: 05/31/16

Time: 11:11:58

PROJECT INFORMATION

Company: Hydrometrics
 Project: 11048
 Test Well: MW-13
 Test Date: Forward

AQUIFER DATA

Saturated Thickness: 20. ft

Anisotropy Ratio (K_z/K_r): 1.

WELL DATA (MW-13)

Initial Displacement: 5.064 ft
 Total Well Penetration Depth: 20. ft
 Casing Radius: 0.08333 ft

Static Water Column Height: 20. ft
 Screen Length: 20. ft
 Well Radius: 0.08333 ft

SOLUTION

Aquifer Model: Unconfined
 $K =$ 1.407 ft/day

Solution Method: Bouwer-Rice
 $y_0 =$ 2.022 ft

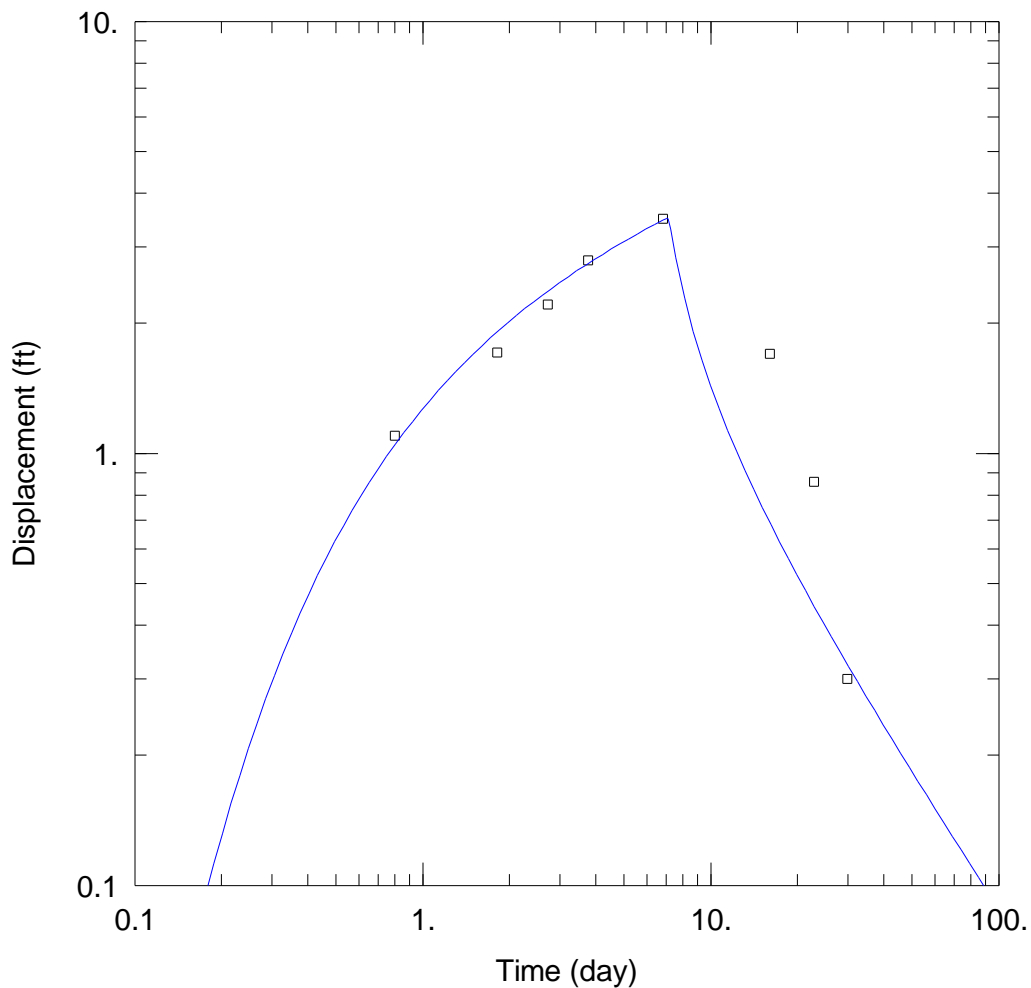

WELL TEST ANALYSIS

Data Set: K:\...\MW_14 Trench_Moenchslab.aqt

Date: 03/14/17

Time: 16:29:13

PROJECT INFORMATION

Company: Hydrometrics, Inc.

Test Date: 12/13/2016

AQUIFER DATA

Saturated Thickness: 10. ft

Slab Block Thickness: 2. ft

WELL DATA

Pumping Wells

Observation Wells

Well Name	X (ft)	Y (ft)
Trench	0	0

Well Name	X (ft)	Y (ft)
□ MW-14	10	0

SOLUTION

Aquifer Model: Fractured

Solution Method: Moench w/slab blocks

K = 7.549 ft/day

Ss = 0.06797 ft⁻¹

K' = 1.122E-10 ft/day

Ss' = 1.995E-10 ft⁻¹

Sw = 0.15

Sf = 0.4

r(w) = 0.5 ft

r(c) = 2. ft

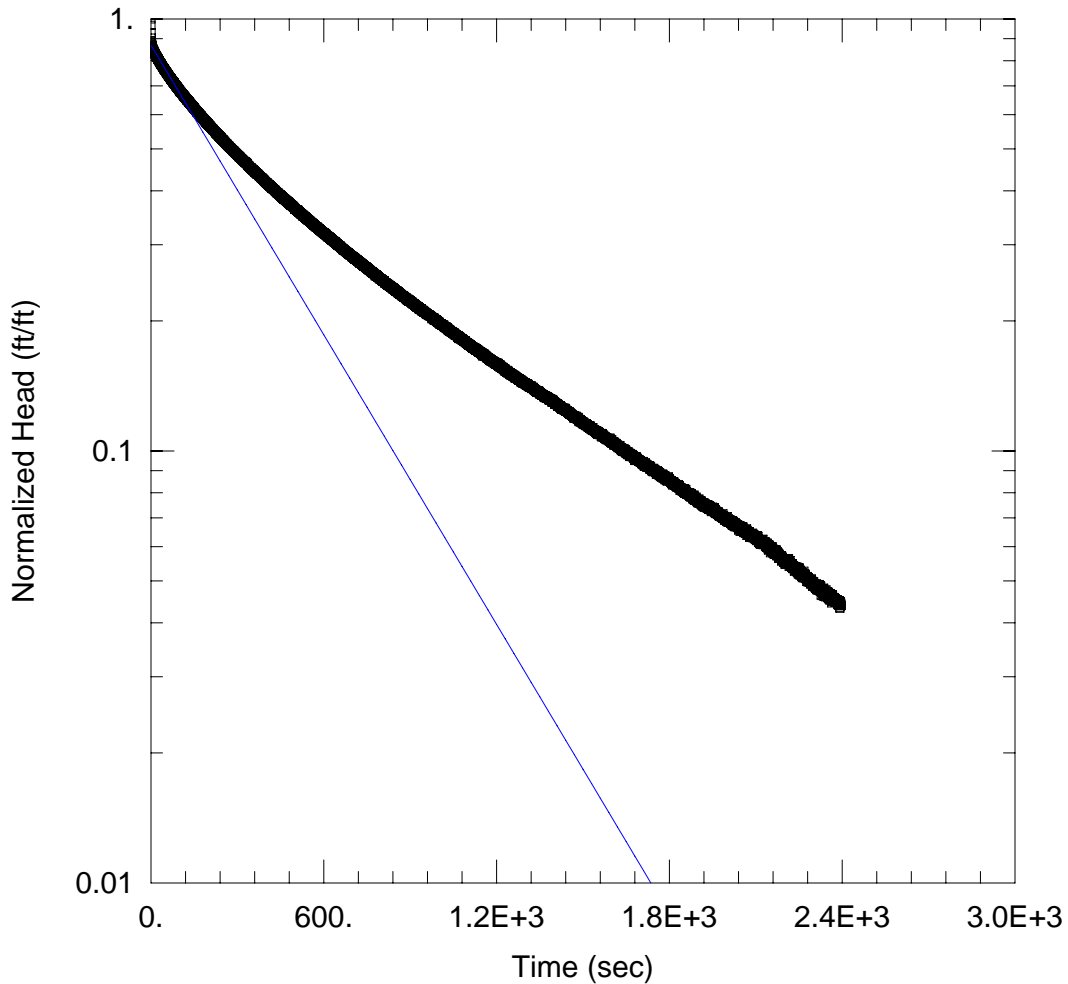

WELL TEST ANALYSIS

Data Set: K:\...\MW_14Slug1BouwerRice.aqt

Date: 03/01/17

Time: 14:52:38

PROJECT INFORMATION

Company: Hydrometrics, Inc.

Client: Tintina Resources

Project: BBC

Location: Eastern UIG

Test Well: MW-15

Test Date: 01/26/2017

AQUIFER DATA

Saturated Thickness: 10. ft

Anisotropy Ratio (Kz/Kr): 1.

WELL DATA (MW-14)

Initial Displacement: 1.777 ft

Static Water Column Height: 0. ft

Total Well Penetration Depth: 26. ft

Screen Length: 10. ft

Casing Radius: 0.083 ft

Well Radius: 0.083 ft

SOLUTION

Aquifer Model: Unconfined

Solution Method: Bouwer-Rice

K = 0.3294 ft/day

y0 = 1.545 ft

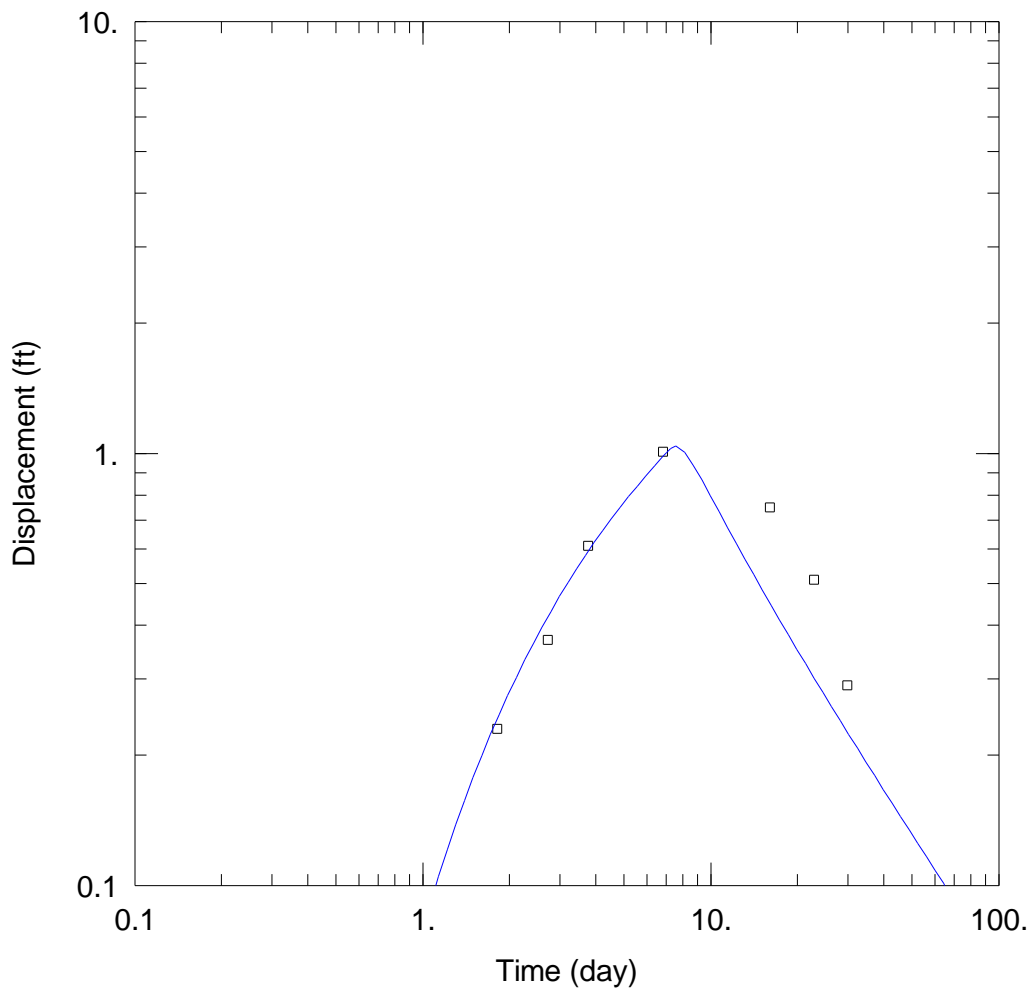

WELL TEST ANALYSIS

Data Set: K:\...\MW_15 Trench_Moenschslab.aqt

Date: 03/14/17

Time: 16:30:41

PROJECT INFORMATION

Company: Hydrometrics, Inc.

Test Date: 12/13/2016

AQUIFER DATA

Saturated Thickness: 10. ft

Slab Block Thickness: 2. ft

WELL DATA

Pumping Wells

Well Name	X (ft)	Y (ft)
Trench	0	0

Observation Wells

Well Name	X (ft)	Y (ft)
□ MW-15	10	0

SOLUTION

Aquifer Model: Fractured

Solution Method: Moench w/slab blocks

K = 10.19 ft/day

Ss = 0.6593 ft⁻¹

K' = 1.585E-7 ft/day

Ss' = 0.001 ft⁻¹

Sw = 0.15

Sf = 0.4

r(w) = 0.5 ft

r(c) = 0.5 ft

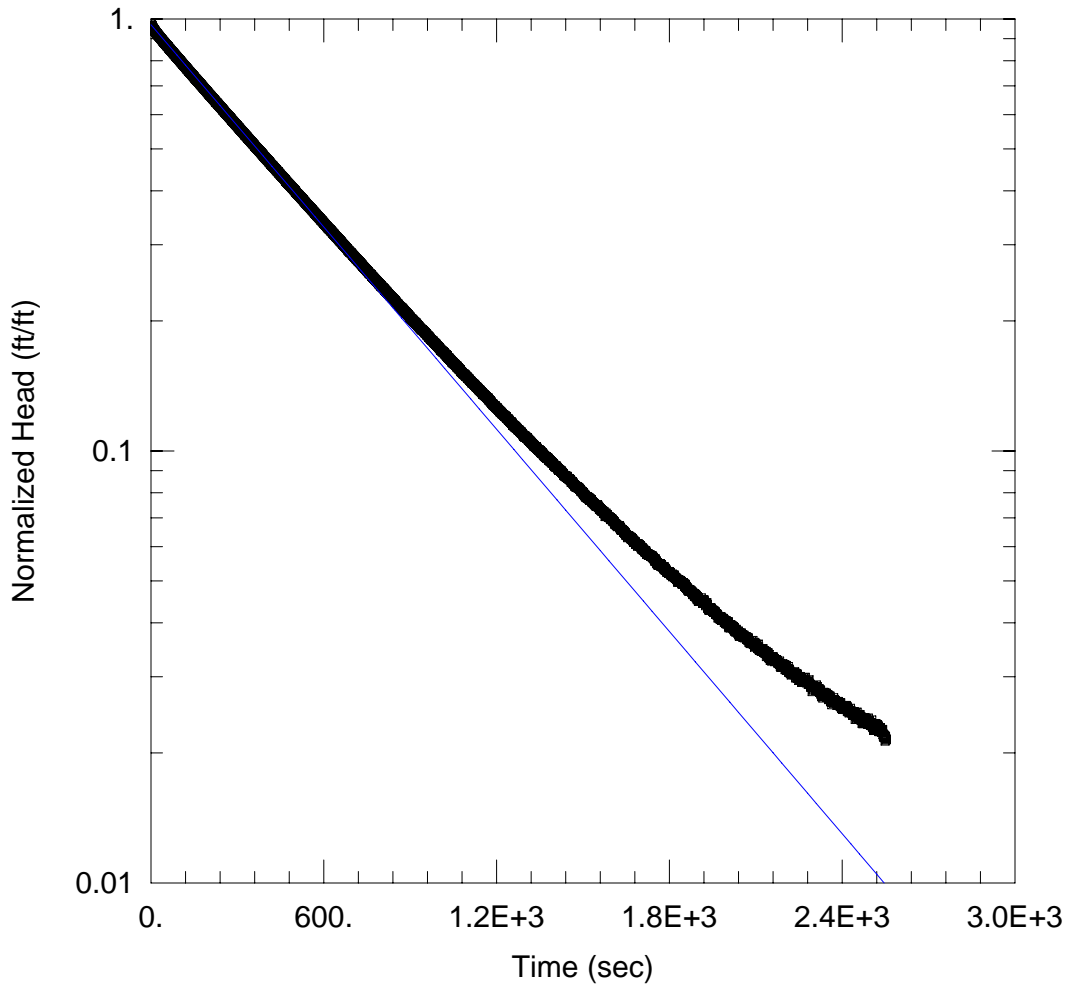

WELL TEST ANALYSIS

Data Set: K:\...\MW_15_Slug1BouwerRice.aqt

Date: 03/01/17

Time: 14:53:46

PROJECT INFORMATION

Company: Hydrometrics, Inc.

Client: Tintina Resources

Project: BBC

Location: Eastern UIG

Test Well: MW-15

Test Date: 01/26/2017

AQUIFER DATA

Saturated Thickness: 10. ft

Anisotropy Ratio (Kz/Kr): 1.

WELL DATA (MW-15)

Initial Displacement: 3.934 ft

Static Water Column Height: 0. ft

Total Well Penetration Depth: 40. ft

Screen Length: 10. ft

Casing Radius: 0.083 ft

Well Radius: 0.083 ft

SOLUTION

Aquifer Model: Unconfined

Solution Method: Bouwer-Rice

K = 0.244 ft/day

y0 = 3.815 ft

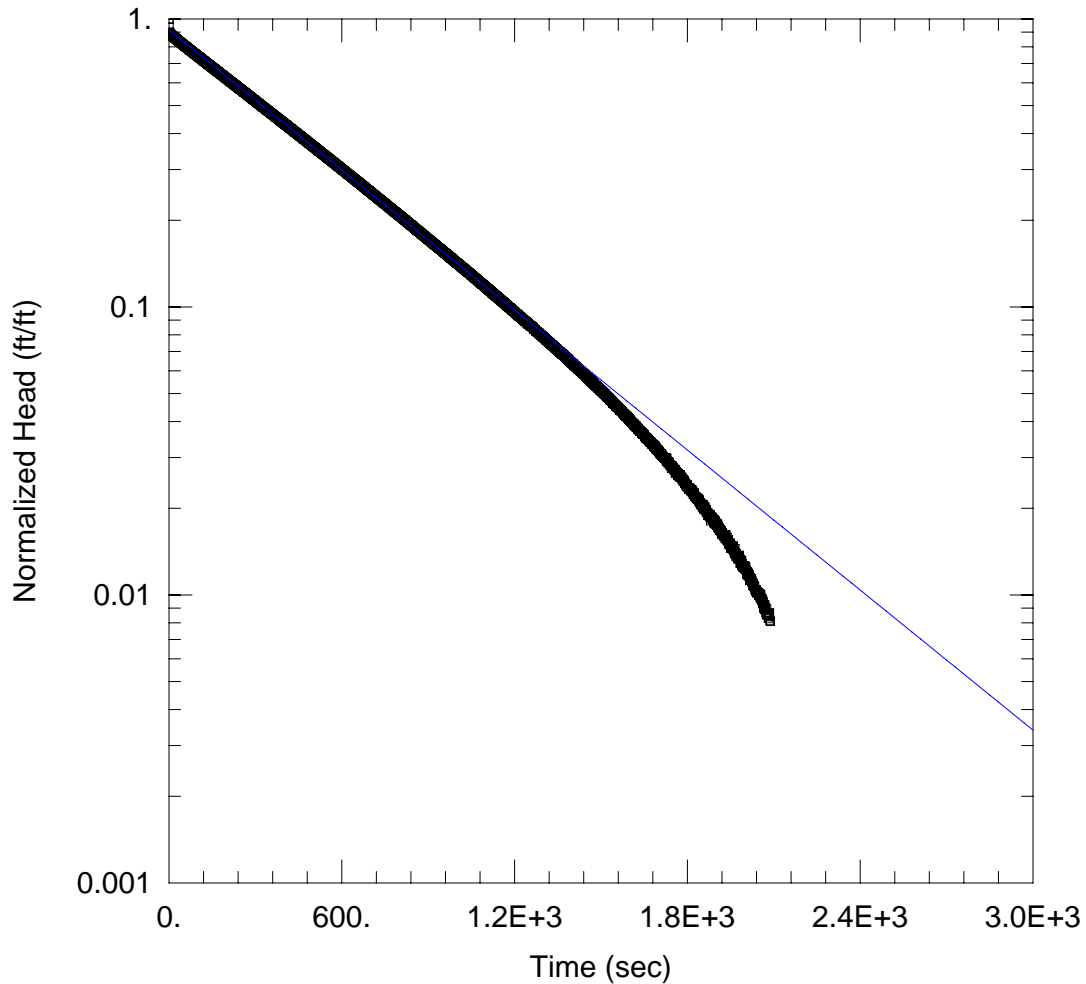

WELL TEST ANALYSIS

Data Set: K:\...\MW_15Slug2BouwerRice.aqt

Date: 03/01/17

Time: 14:54:45

PROJECT INFORMATION

Company: Hydrometrics, Inc.

Client: Tintina Resources

Project: BBC

Location: Eastern UIG

Test Well: MW-15

Test Date: 01/26/2017

AQUIFER DATA

Saturated Thickness: 10. ft

Anisotropy Ratio (Kz/Kr): 1.

WELL DATA (MW-15)

Initial Displacement: 4.95 ft

Static Water Column Height: 0. ft

Total Well Penetration Depth: 40. ft

Screen Length: 10. ft

Casing Radius: 0.083 ft

Well Radius: 0.083 ft

SOLUTION

Aquifer Model: Unconfined

Solution Method: Bouwer-Rice

K = 0.2534 ft/day

y0 = 4.533 ft

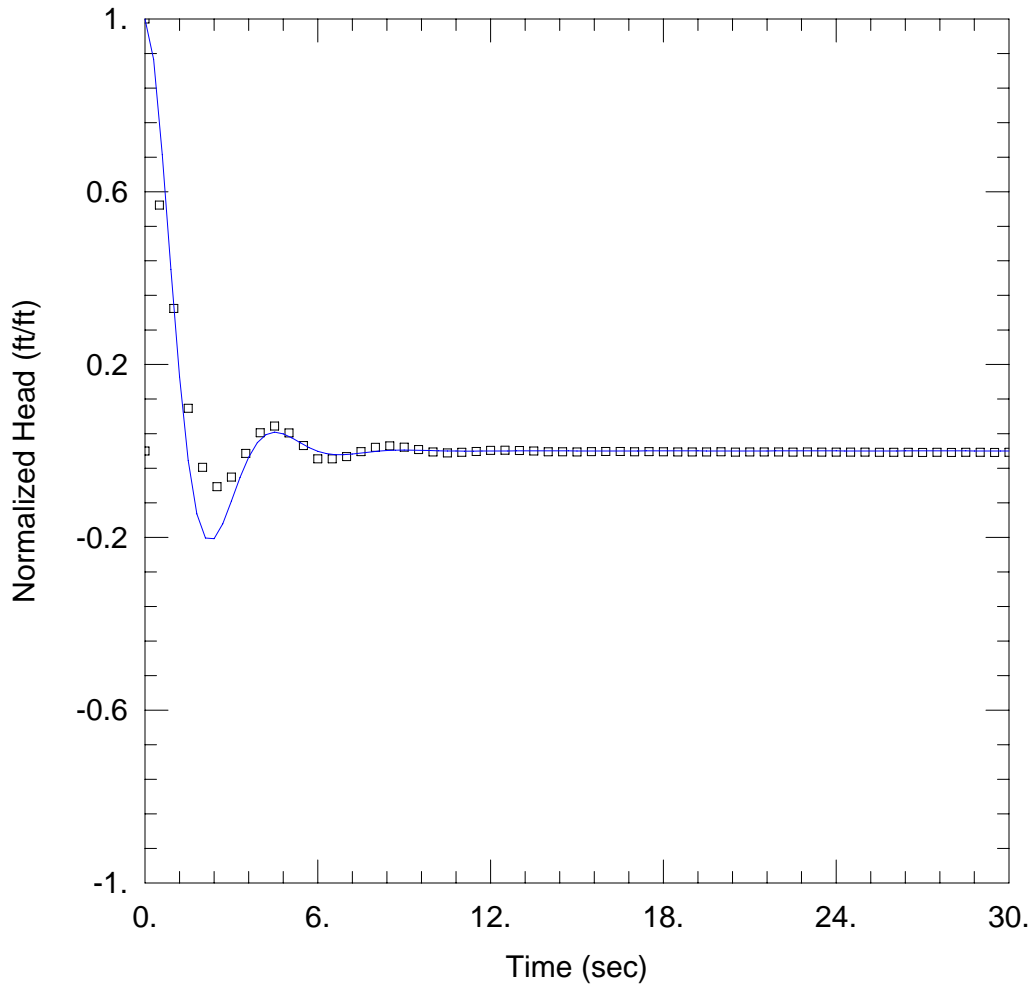

WELL TEST ANALYSIS

Data Set: K:\...\MW-4A_Test3.aqt
 Date: 08/24/15

Time: 16:10:19

AQUIFER DATA

Saturated Thickness: 19.4 ft

Anisotropy Ratio (Kz/Kr): 1.

WELL DATA (MW-4A)

Initial Displacement: 4.6 ft
 Total Well Penetration Depth: 19.4 ft
 Casing Radius: 0.083 ft

Static Water Column Height: 19.4 ft
 Screen Length: 10. ft
 Well Radius: 0.083 ft

SOLUTION

Aquifer Model: Unconfined

Solution Method: Springer-Gelhar

K = 216.2 ft/day

Le = 13.26 ft

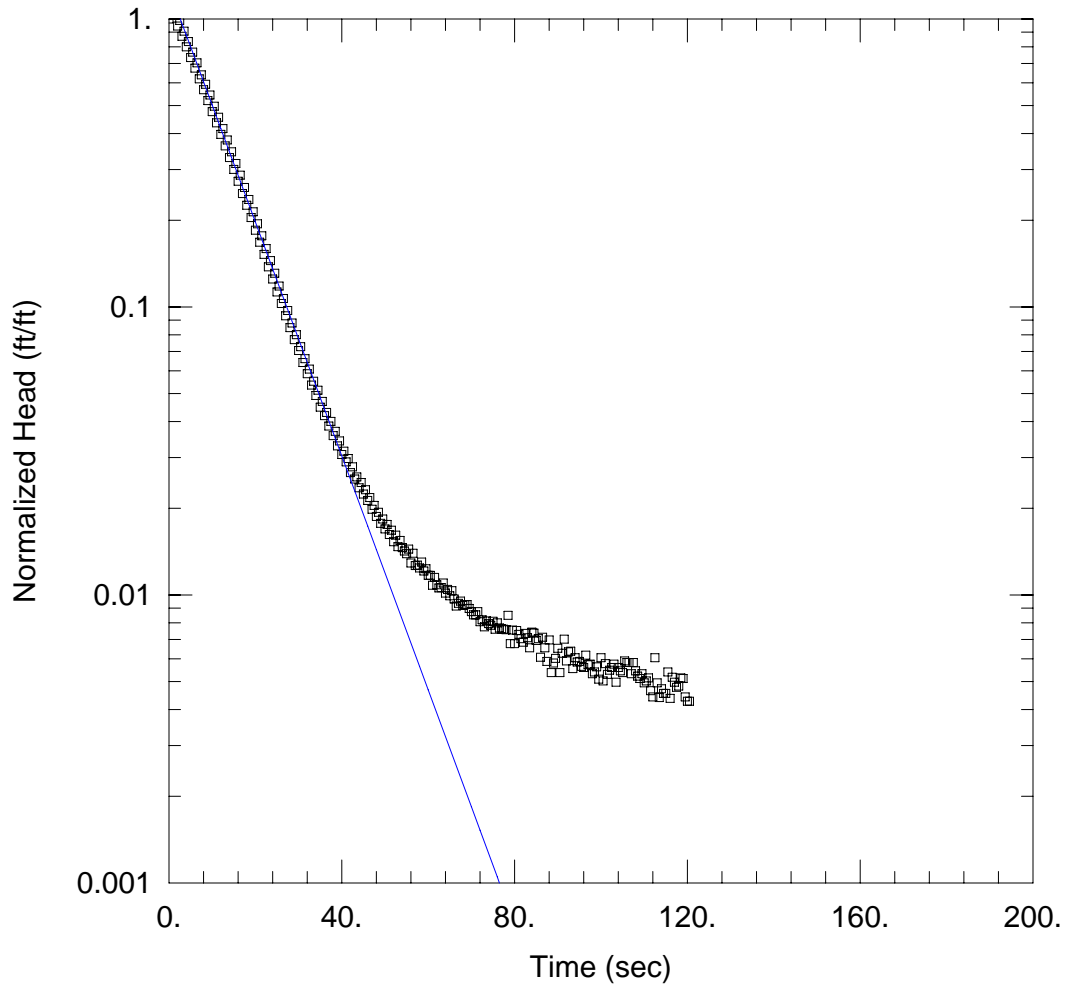

WELL TEST ANALYSIS

Data Set: K:\...\MW-4B_Test1.aqt
 Date: 08/24/15

Time: 16:14:30

AQUIFER DATA

Saturated Thickness: 20. ft

Anisotropy Ratio (Kz/Kr): 1.

WELL DATA (MW-4B)

Initial Displacement: 4. ft
 Total Well Penetration Depth: 56. ft
 Casing Radius: 0.083 ft

Static Water Column Height: 56. ft
 Screen Length: 20. ft
 Well Radius: 0.083 ft

SOLUTION

Aquifer Model: Confined

Solution Method: Hvorslev

K = 7.371 ft/day

y0 = 5.113 ft

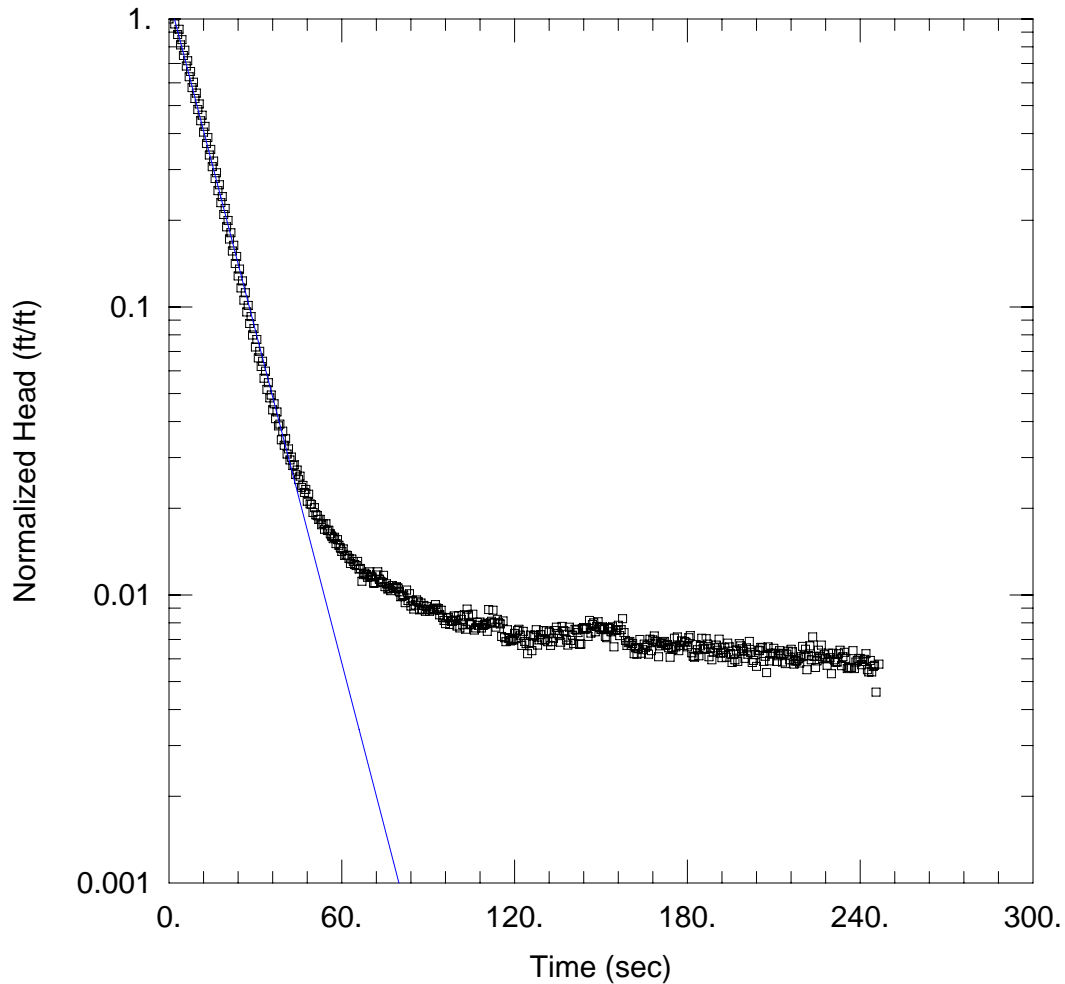

WELL TEST ANALYSIS

Data Set: K:\...\MW-4B_Test2.aqt
 Date: 08/24/15

Time: 16:15:16

AQUIFER DATA

Saturated Thickness: 20. ft

Anisotropy Ratio (Kz/Kr): 1.

WELL DATA (MW-4B)

Initial Displacement: 4. ft
 Total Well Penetration Depth: 56. ft
 Casing Radius: 0.083 ft

Static Water Column Height: 56. ft
 Screen Length: 20. ft
 Well Radius: 0.083 ft

SOLUTION

Aquifer Model: Confined

Solution Method: Hvorslev

K = 6.988 ft/day

y0 = 4.738 ft

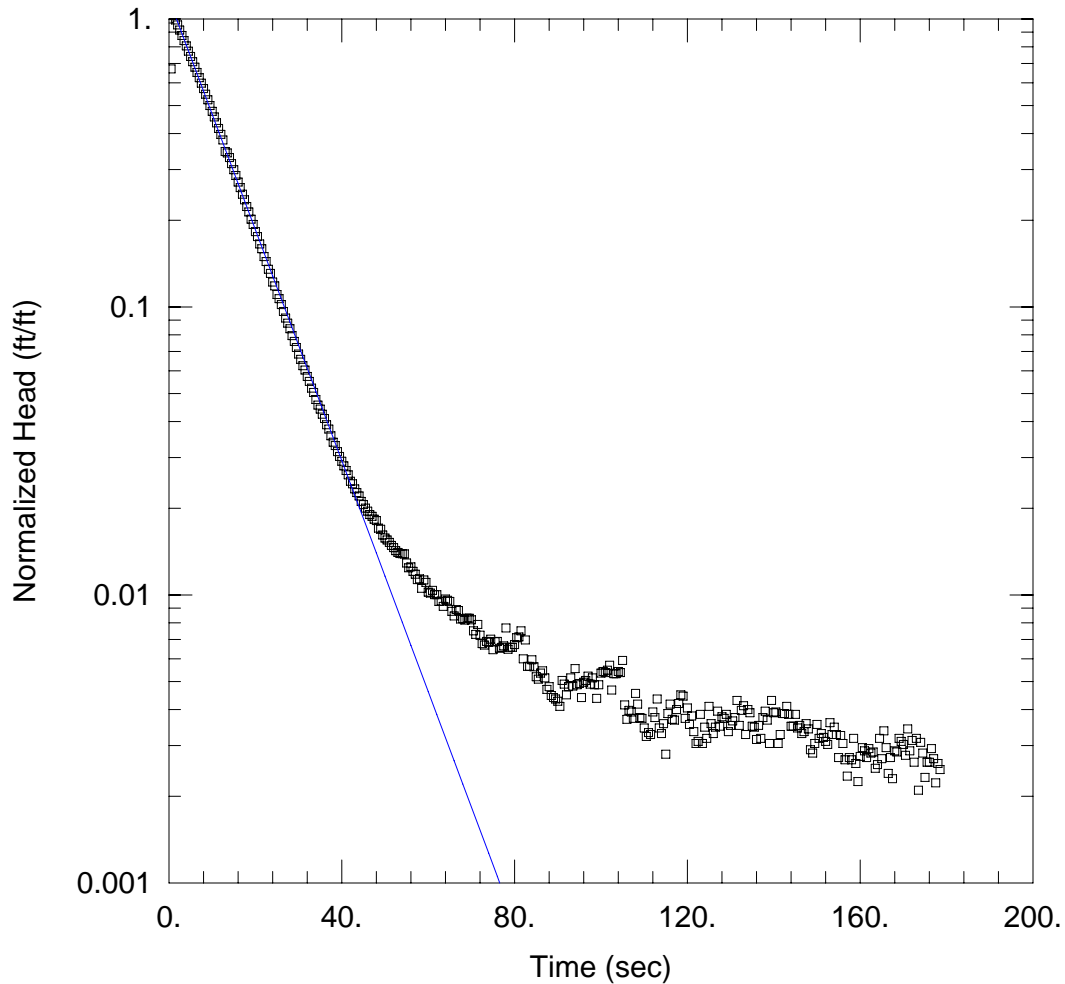

WELL TEST ANALYSIS

Data Set: K:\...\MW-4B_Test3.aqt
 Date: 08/24/15

Time: 16:14:55

AQUIFER DATA

Saturated Thickness: 20. ft

Anisotropy Ratio (K_z/K_r): 1.

WELL DATA (MW-4B)

Initial Displacement: 4. ft
 Total Well Penetration Depth: 56. ft
 Casing Radius: 0.083 ft

Static Water Column Height: 56. ft
 Screen Length: 20. ft
 Well Radius: 0.083 ft

SOLUTION

Aquifer Model: Confined

Solution Method: Hvorslev

$K = 7.277$ ft/day

$y_0 = 4.696$ ft

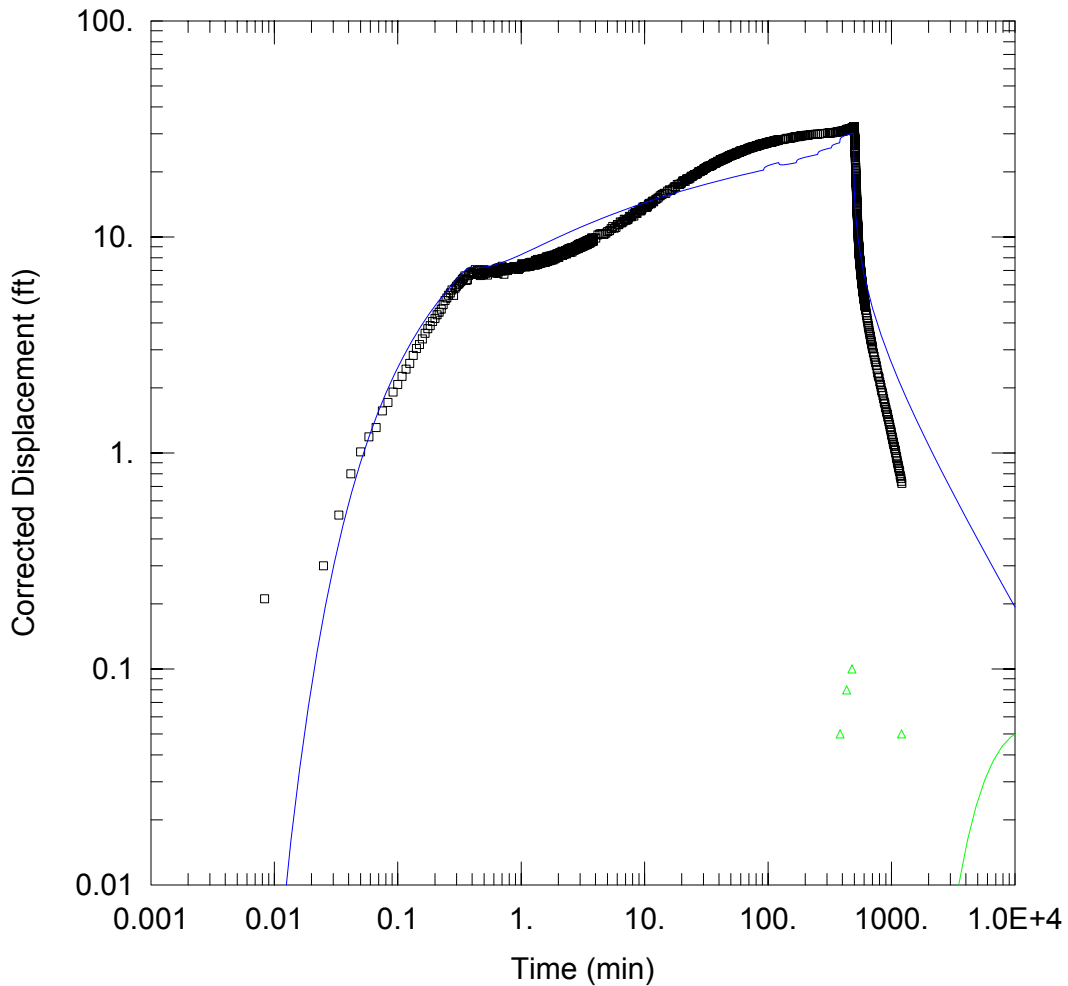

PROJECT INFORMATION

Company: Hydrometrics, Inc.
 Client: Tintina Resources
 Project: 11048
 Location: Black Butte Copper Project
 Test Well: PW-1
 Test Date: 11/15/2011

WELL DATA

Pumping Wells			Observation Wells		
Well Name	X (ft)	Y (ft)	Well Name	X (ft)	Y (ft)
PW-1	0	0	□ PW-1	0	0
			△ AH-4	200	0

SOLUTION

Aquifer Model: <u>Unconfined</u>	Solution Method: <u>Theis</u>
T = <u>6.793</u> ft ² /day	S = <u>0.006227</u>
Kz/Kr = <u>1.</u>	b = <u>100.</u> ft

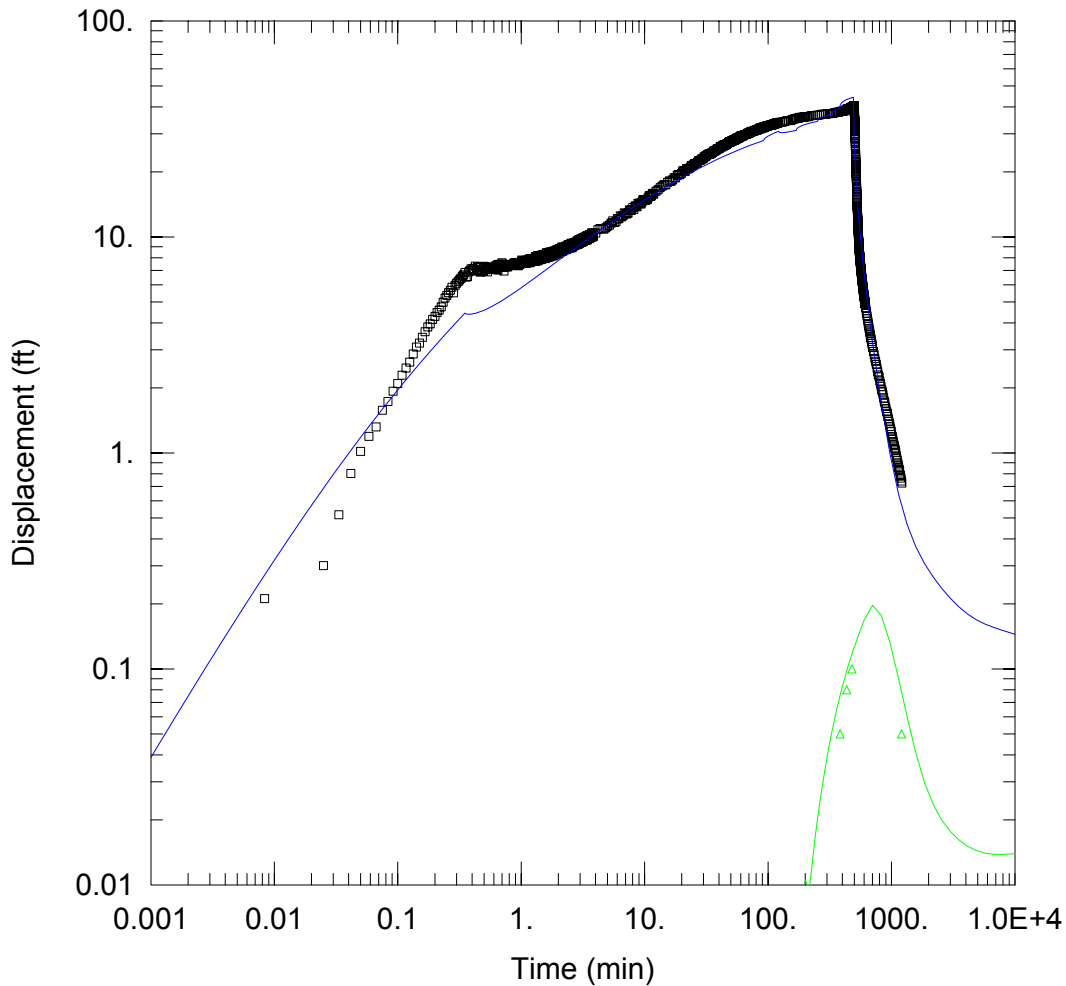

PROJECT INFORMATION

Company: Hydrometrics, Inc.
 Client: Tintina Resources
 Project: 11048
 Location: Black Butte Copper Project
 Test Well: PW-1
 Test Date: 11/15/2011

AQUIFER DATA

Saturated Thickness: 100. ft Slab Block Thickness: 10. ft

WELL DATA

Pumping Wells

Well Name	X (ft)	Y (ft)
PW-1	0	0

Observation Wells

Well Name	X (ft)	Y (ft)
□ PW-1	0	0
△ AH-4	200	0

SOLUTION

Aquifer Model: Fractured

Solution Method: Moench w/slab blocks

$K = 0.02552$ ft/day
 $K' = 0.001637$ ft/day
 $Sw = -0.6352$
 $r(w) = 5.012$ ft

$Ss = 1.651E-6$ ft⁻¹
 $Ss' = 0.000158$ ft⁻¹
 $Sf = 1.75$
 $r(c) = 0.04764$ ft

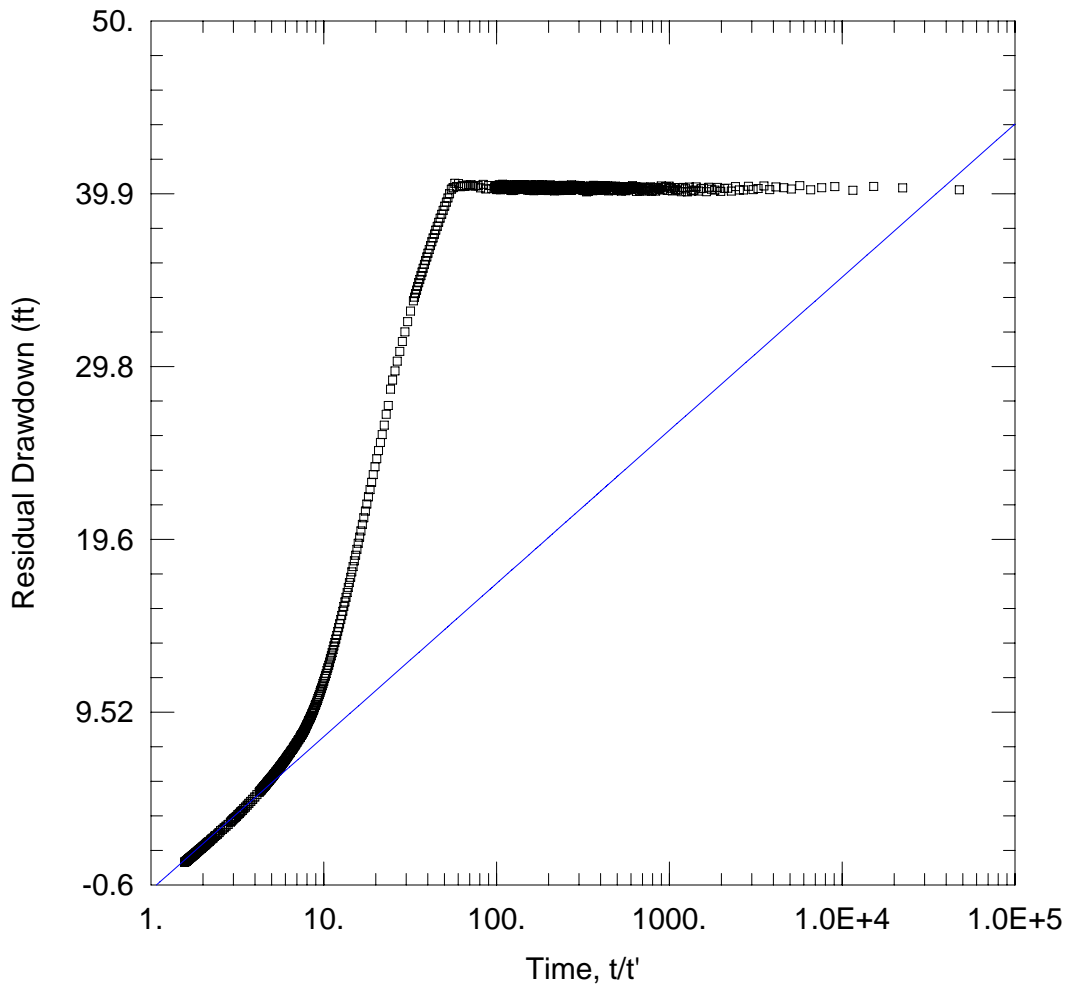

WELL TEST ANALYSIS

Data Set: K:\project\11048\GW\PW-1 rec.aqt

Date: 08/27/15

Time: 11:04:02

PROJECT INFORMATION

Company: Hydrometrics, Inc.

Client: Tintina Resources

Project: 11048

Location: Black Butte Copper Project

Test Well: PW-1

Test Date: 11/15/2011

AQUIFER DATA

Saturated Thickness: 100. ft

Anisotropy Ratio (Kz/Kr): 3.484E+4

WELL DATA

Pumping Wells

Well Name	X (ft)	Y (ft)
PW-1	0	0

Observation Wells

Well Name	X (ft)	Y (ft)
□ PW-1	0	0

SOLUTION

Aquifer Model: Confined

Solution Method: Theis (Recovery)

T = 7.866 ft²/day

S/S' = 1.256

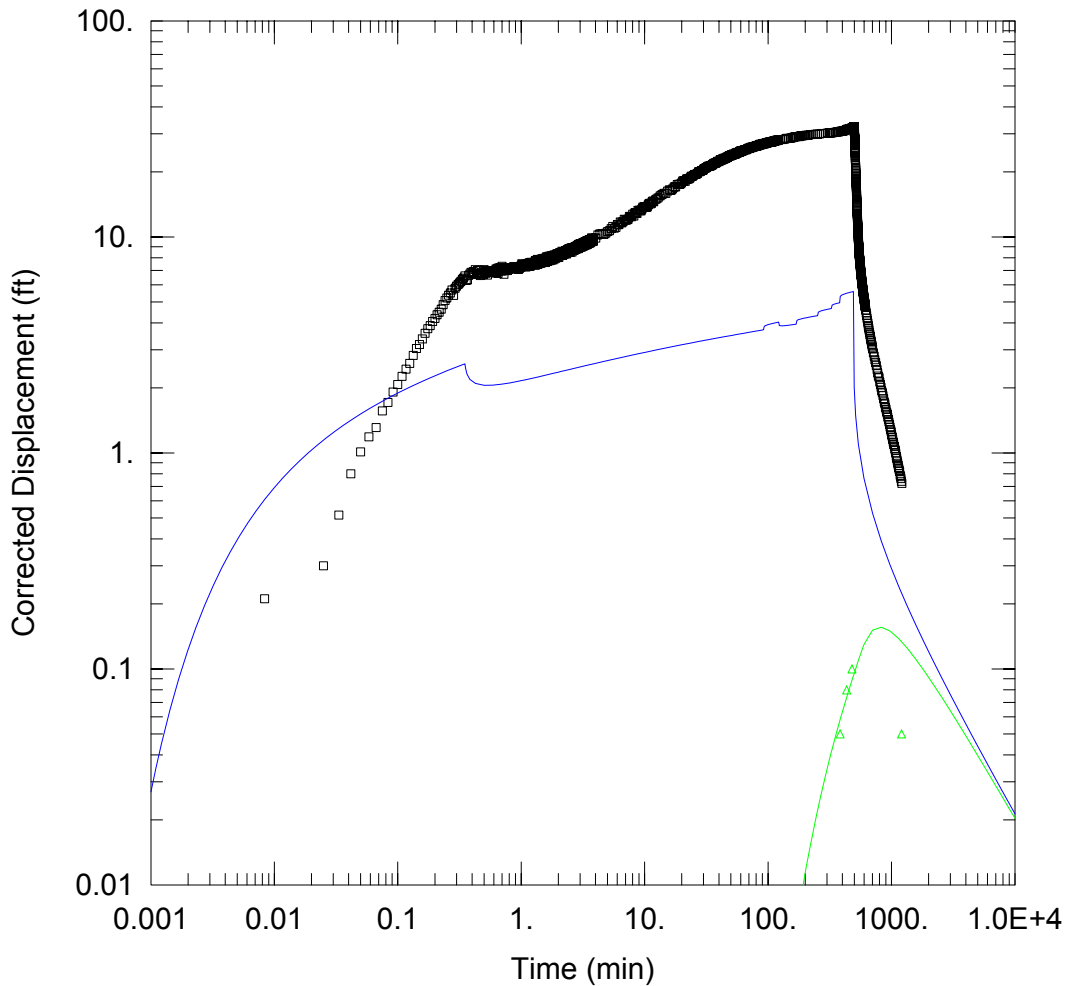

PROJECT INFORMATION

Company: Hydrometrics, Inc.
 Client: Tintina Resources
 Project: 11048
 Location: Black Butte Copper Project
 Test Well: PW-1
 Test Date: 11/15/2011

WELL DATA

Pumping Wells			Observation Wells		
Well Name	X (ft)	Y (ft)	Well Name	X (ft)	Y (ft)
PW-1	0	0	□ PW-1	0	0
			△ AH-4	200	0

SOLUTION

Aquifer Model: <u>Unconfined</u>	Solution Method: <u>Theis</u>
T = <u>61.61 ft²/day</u>	S = <u>0.002014</u>
Kz/Kr = <u>3.484E+4</u>	b = <u>100. ft</u>

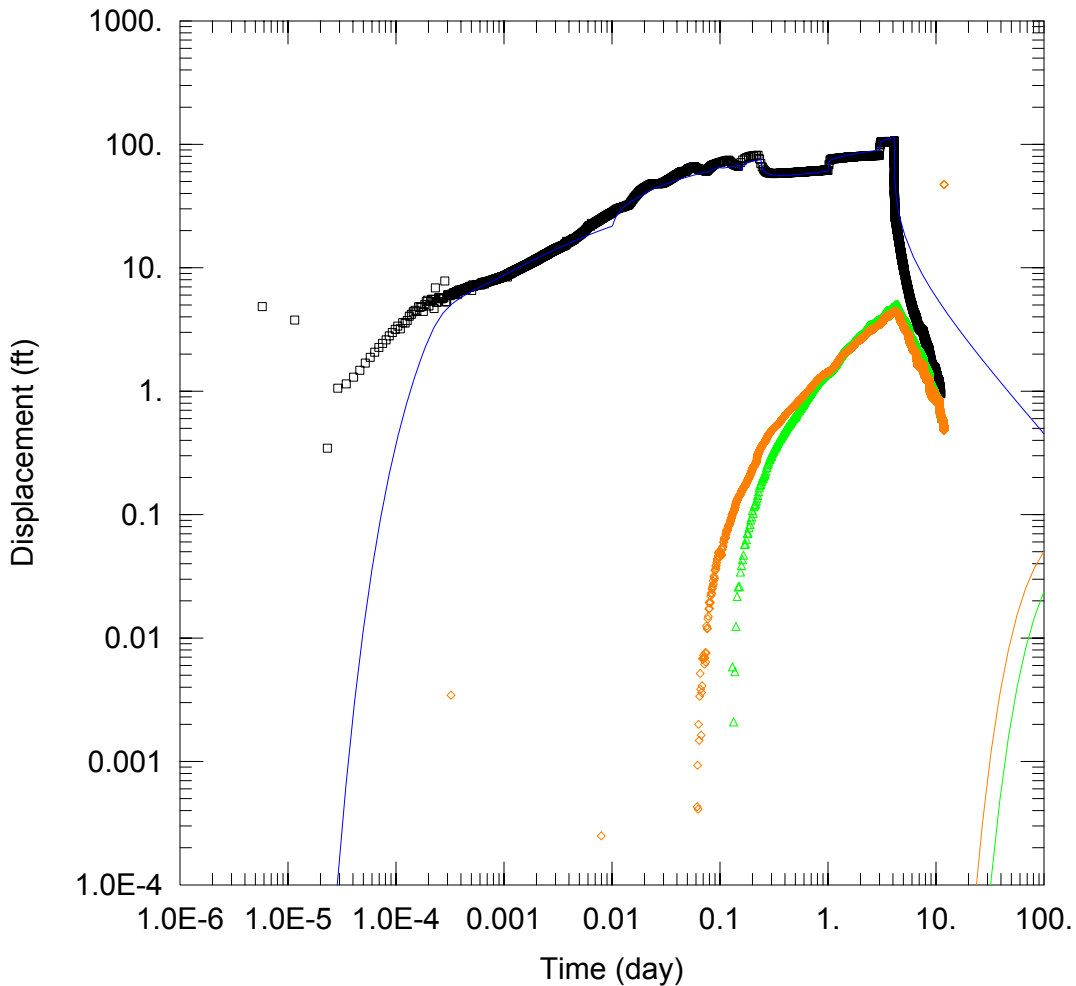

PROJECT INFORMATION

Company: Hydrometrics, Inc.
 Client: Tintina Resources
 Project: 11048
 Location: Black Butte Copper Project
 Test Well: PW-2
 Test Date: 11/18/2011

WELL DATA

Pumping Wells			Observation Wells		
Well Name	X (ft)	Y (ft)	Well Name	X (ft)	Y (ft)
PW-2	1661559	16997589	□ PW-2	1661559	16997589
			△ MW-3	1661693	16997179
			◇ SC11-044	1661312	16997868

SOLUTION

Aquifer Model: Confined
 $T = 6.44 \text{ ft}^2/\text{day}$
 $Kz/Kr = 5.408E+4$

Solution Method: Theis
 $S = 0.03992$
 $b = 100. \text{ ft}$

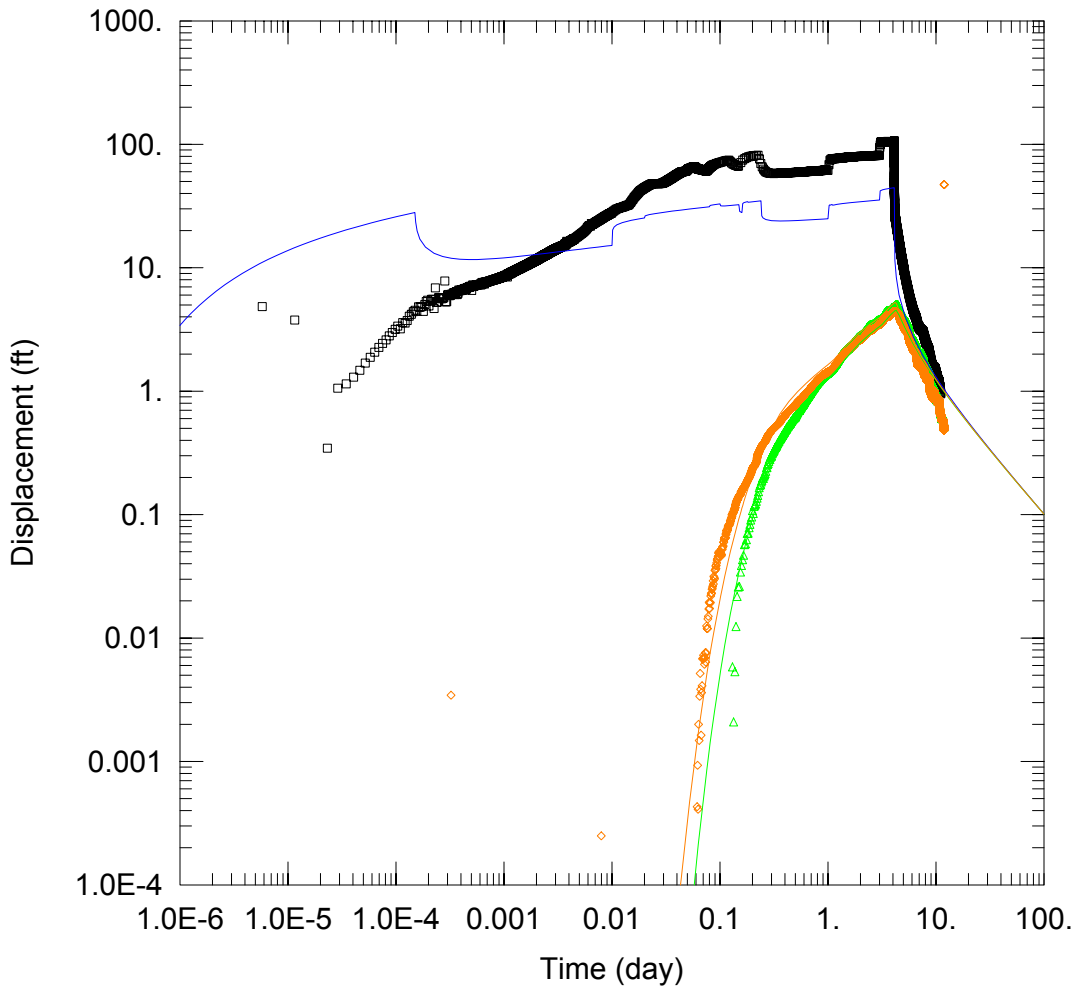

PROJECT INFORMATION

Company: Hydrometrics, Inc.
 Client: Tintina Resources
 Project: 11048
 Location: Black Butte Copper Project
 Test Well: PW-2
 Test Date: 11/18/2011

WELL DATA

Pumping Wells			Observation Wells		
Well Name	X (ft)	Y (ft)	Well Name	X (ft)	Y (ft)
PW-2	1661559	16997589	□ PW-2	1661559	16997589
			△ MW-3	1661693	16997179
			◇ SC11-044	1661312	16997868

SOLUTION

Aquifer Model: Confined

Solution Method: Theis

T = 28.76 ft²/day

S = 0.0002733

Kz/Kr = 5.408E+4

b = 100. ft

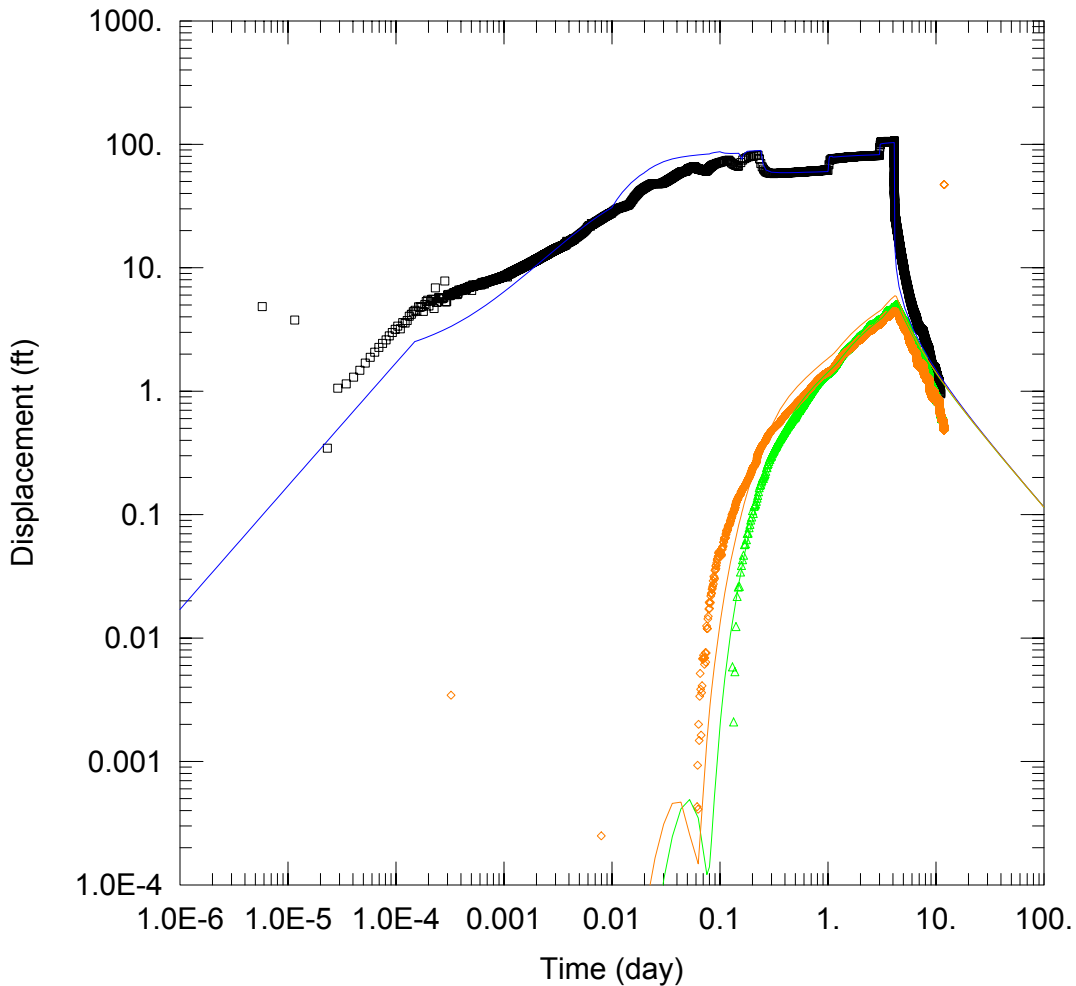

PROJECT INFORMATION

Company: Hydrometrics, Inc.
 Client: Tintina Resources
 Location: Black Butte Copper Project
 Test Well: PW-2

AQUIFER DATA

Saturated Thickness: 100. ft Slab Block Thickness: 1. ft

WELL DATA

Pumping Wells

Well Name	X (ft)	Y (ft)
PW-2	1661559	16997589

Observation Wells

Well Name	X (ft)	Y (ft)
□ PW-2	1661559	16997589
△ MW-3	1661693	16997179
◇ SC11-044	1661312	16997868

SOLUTION

Aquifer Model: Fractured

Solution Method: Moench w/slab blocks

K = 0.2522 ft/day
 K' = 1.0E-10 ft/day
 Sw = 7.975
 r(w) = 0.4608 ft

Ss = 2.413E-6 ft⁻¹
 Ss' = 1.0E-6 ft⁻¹
 Sf = 5.
 r(c) = 0.1896 ft

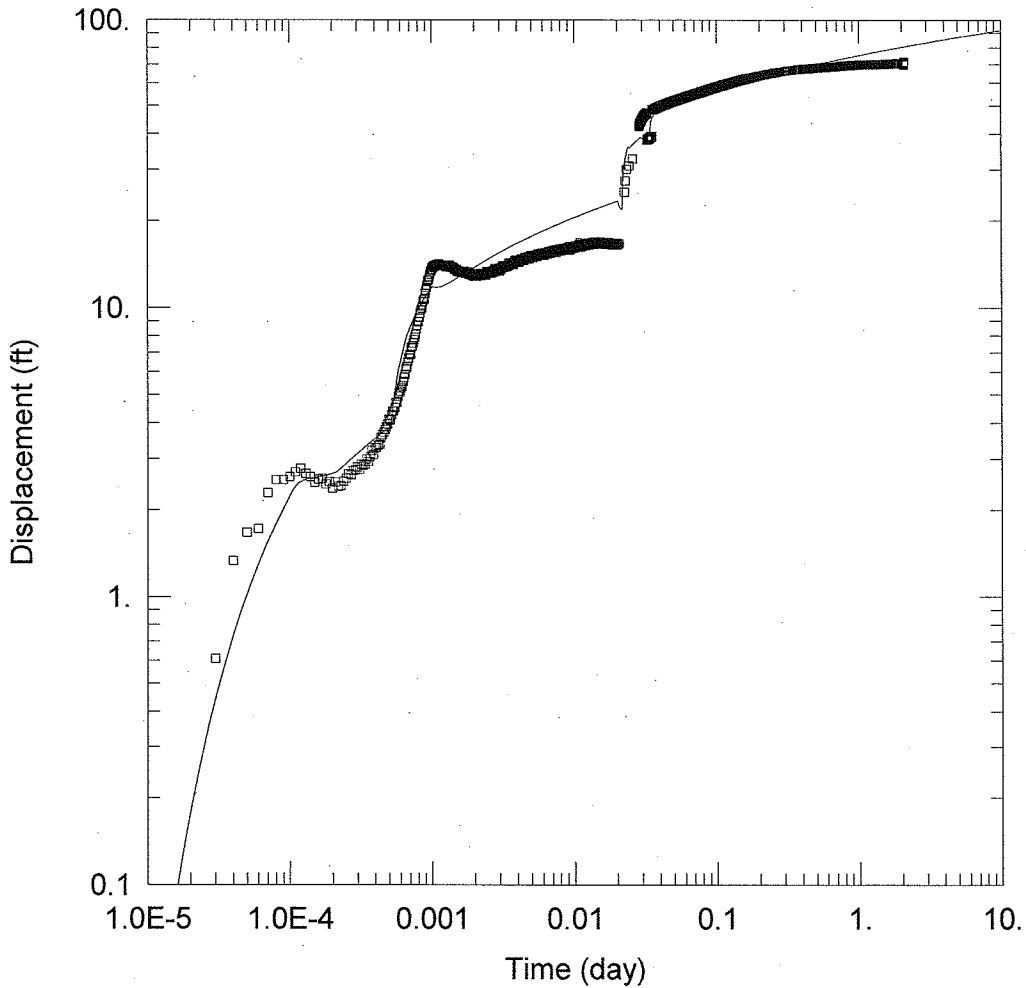

WELL TEST ANALYSIS

Data Set: K:\project\11048\GWAqtesolve Files Aquifer Tests\Pw-3 Pump Test PW-3 Theis.aqt
 Date: 08/13/12 Time: 06:57:14

PROJECT INFORMATION

Company: Hydrometrics
 Client: Tintina
 Location: Black Butte
 Test Well: PW-3

WELL DATA

Pumping Wells			Observation Wells		
Well Name	X (ft)	Y (ft)	Well Name	X (ft)	Y (ft)
PW-3	0	0	□ PW-3	0	0

SOLUTION

Aquifer Model: <u>Confined</u>	Solution Method: <u>Theis</u>
T = <u>106.3</u> ft ² /day	S = <u>10.39</u>
Kz/Kr = <u>1.</u>	b = <u>75.</u> ft

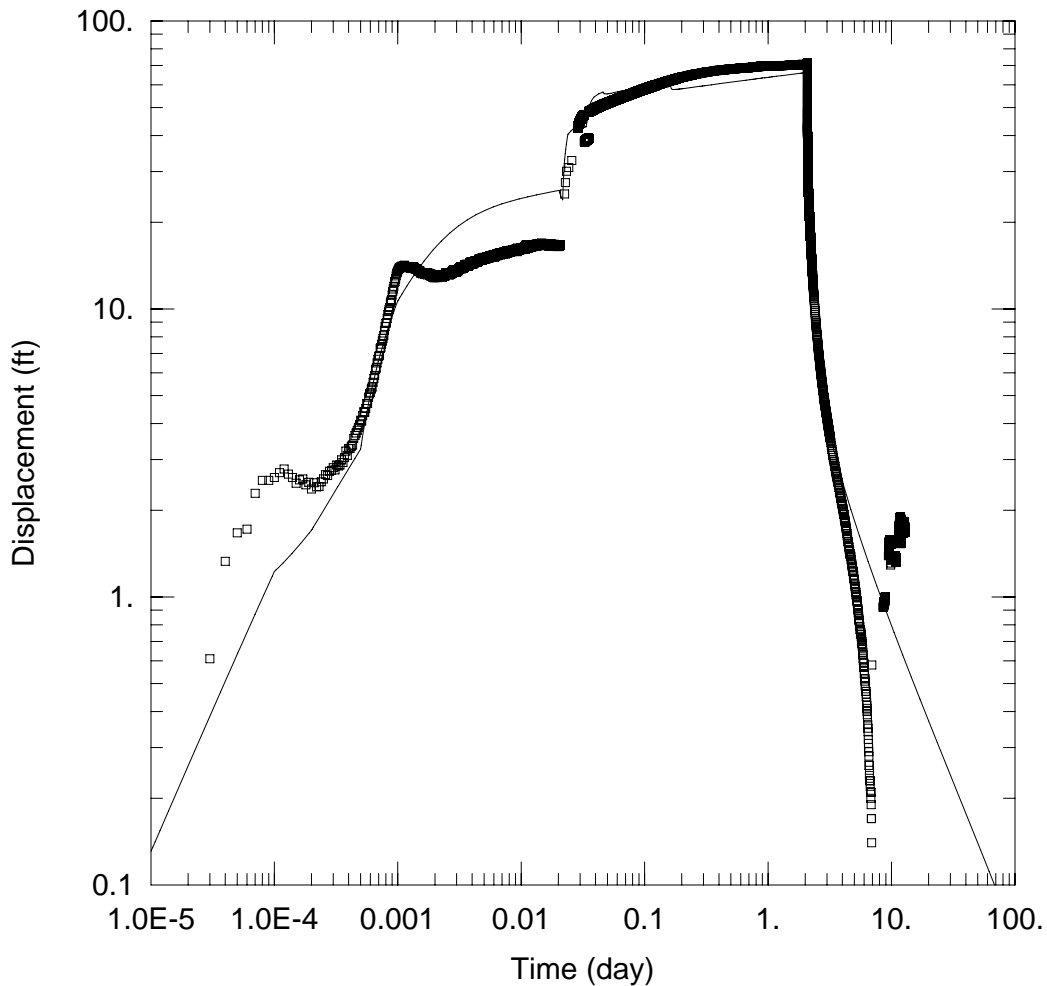

WELL TEST ANALYSIS

Data Set: K:\project\11048\GWAqtesolve Files Aquifer Tests\Pw-3 Pump Test PW-3 Moench.aqt
 Date: 08/27/15 Time: 11:31:50

PROJECT INFORMATION

Company: Hydrometrics
 Client: Tintina
 Location: Black Butte
 Test Well: PW-3

AQUIFER DATA

Saturated Thickness: 75. ft Slab Block Thickness: 1. ft

WELL DATA

Pumping Wells			Observation Wells		
Well Name	X (ft)	Y (ft)	Well Name	X (ft)	Y (ft)
PW-3	0	0	□ PW-3	0	0

SOLUTION

Aquifer Model: <u>Fractured</u>	Solution Method: <u>Moench w/slab blocks</u>
K = <u>1.6 ft/day</u>	Ss = <u>1.2E-6 ft⁻¹</u>
K' = <u>3.481E-6 ft/day</u>	Ss' = <u>2.818E-6 ft⁻¹</u>
Sw = <u>-3.225</u>	Sf = <u>20.</u>
r(w) = <u>0.07726 ft</u>	r(c) = <u>0.2679 ft</u>

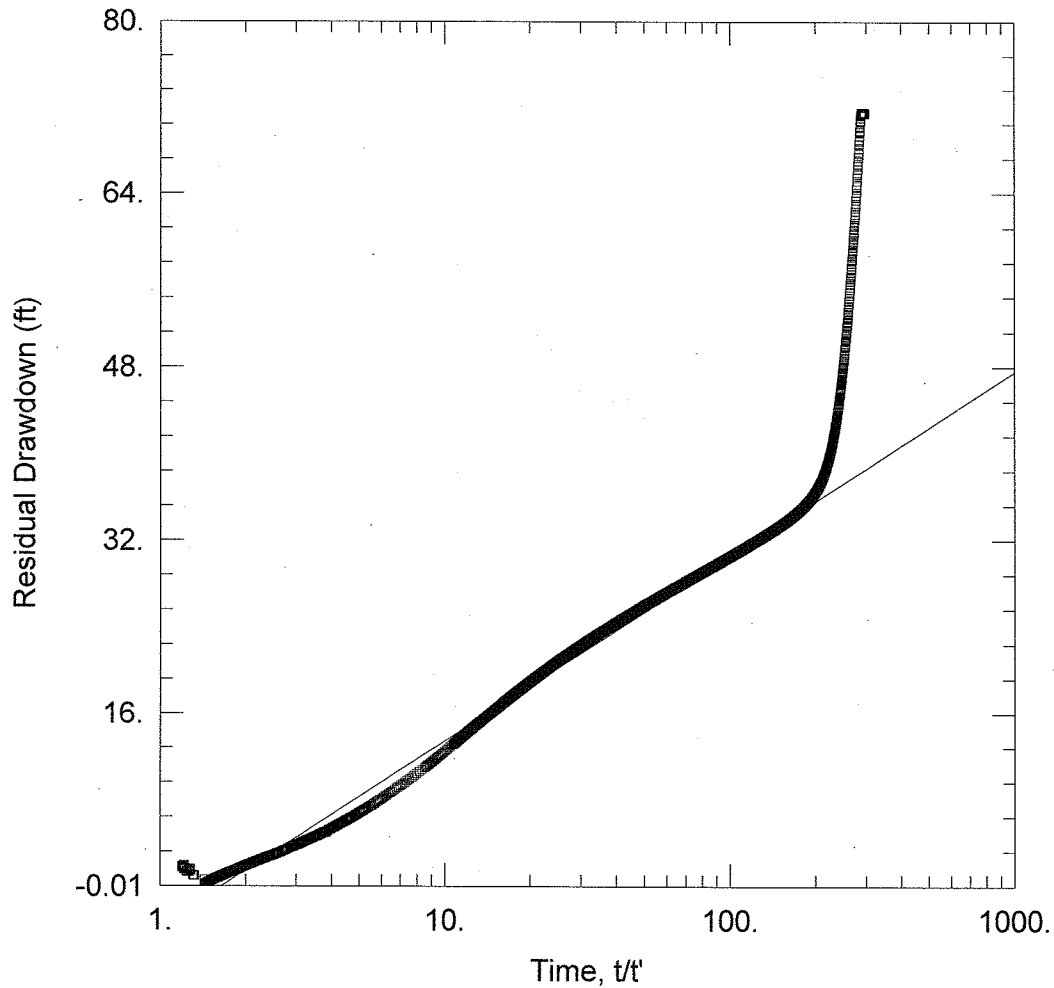

WELL TEST ANALYSIS

Data Set: K:\project\11048\GWA\qtesolve Files Aquifer Tests\Pw-3 Pump Test PW-3 Theis rec.aqt
 Date: 08/13/12 Time: 06:58:31

PROJECT INFORMATION

Company: Hydrometrics
 Client: Tintina
 Location: Black Butte
 Test Well: PW-3

AQUIFER DATA

Saturated Thickness: 75. ft Anisotropy Ratio (Kz/Kr): 1.

WELL DATA

Pumping Wells			Observation Wells		
Well Name	X (ft)	Y (ft)	Well Name	X (ft)	Y (ft)
PW-3	0	0	□ PW-3	0	0

SOLUTION

Aquifer Model: Confined Solution Method: Theis (Recovery)
 T = 55.73 ft²/day S/S' = 1.644

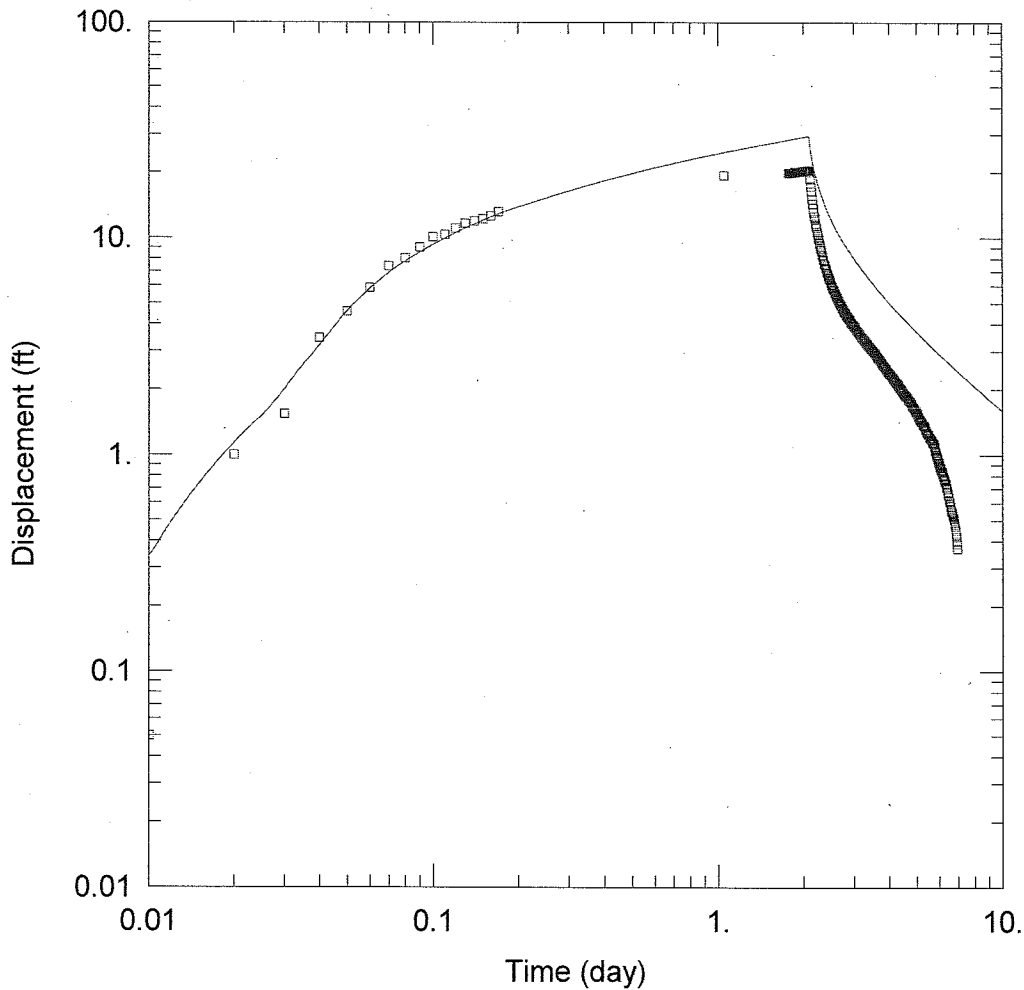

WELL TEST ANALYSIS

Data Set: K:\project\11048\GWA\qtesolve Files Aquifer Tests\Pw-3 Pump Test AH12-5 Theis rec.aqt
 Date: 08/13/12 Time: 06:55:40

PROJECT INFORMATION

Company: Hydrometrics
 Client: Tintina
 Location: Black Butte
 Test Well: PW-3

WELL DATA

Pumping Wells			Observation Wells		
Well Name	X (ft)	Y (ft)	Well Name	X (ft)	Y (ft)
PW-3	0	0	□ SC12-16	775	0

SOLUTION

Aquifer Model: Confined

Solution Method: Theis

T = 60. ft²/day

S = 6.5E-6

Kz/Kr = 1.

b = 75. ft

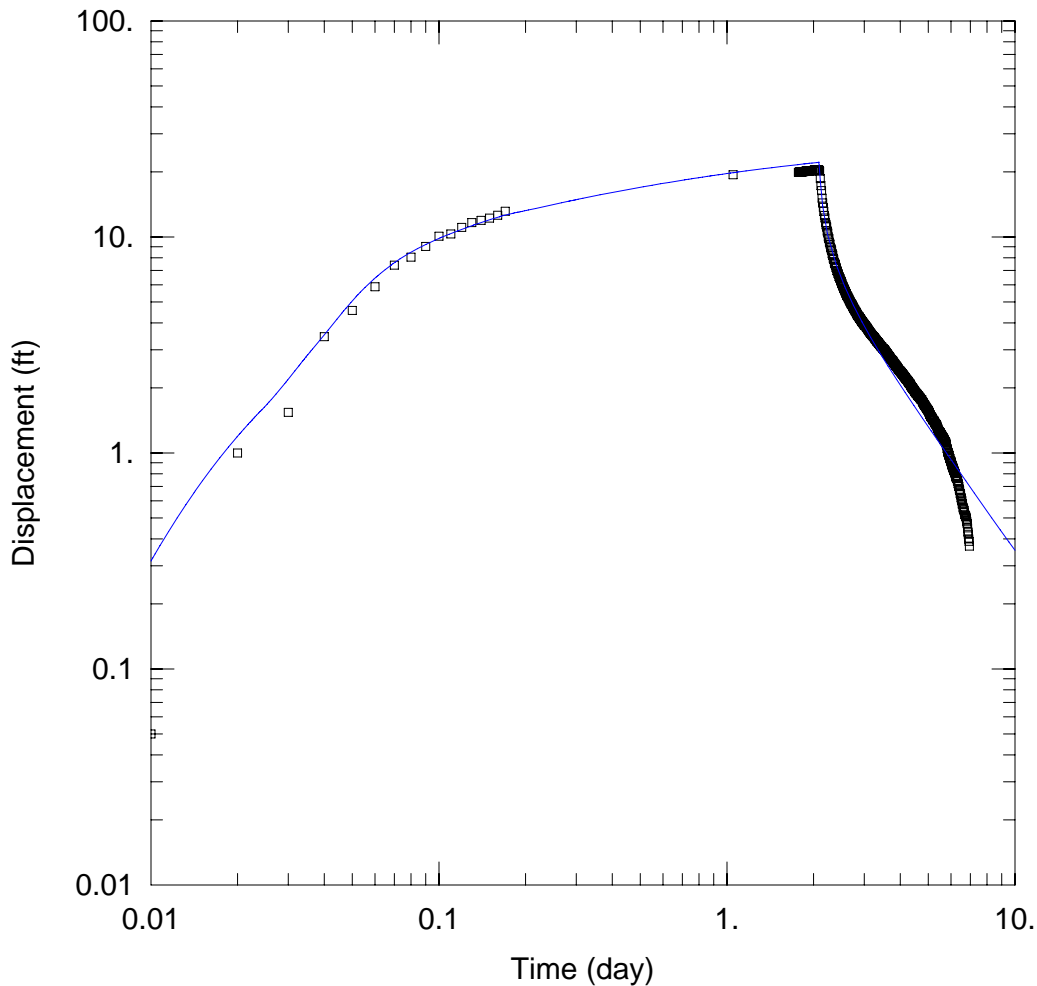

WELL TEST ANALYSIS

Data Set: K:\project\11048\GWAqtesolve Files Aquifer Tests\Pw-3 Pump Test SC12-16 Moench.aqt
 Date: 08/27/15 Time: 11:36:57

PROJECT INFORMATION

Company: Hydrometrics
 Client: Tintina
 Location: Black Butte
 Test Well: PW-3

AQUIFER DATA

Saturated Thickness: 75. ft Slab Block Thickness: 1. ft

WELL DATA

Pumping Wells			Observation Wells		
Well Name	X (ft)	Y (ft)	Well Name	X (ft)	Y (ft)
PW-3	0	0	□ SC12-116	775	0

SOLUTION

Aquifer Model: <u>Fractured</u>	Solution Method: <u>Moench w/slab blocks</u>
K = <u>1.3 ft/day</u>	Ss = <u>4.0E-8 ft⁻¹</u>
K' = <u>3.98E-7 ft/day</u>	Ss' = <u>2.5E-6 ft⁻¹</u>
Sw = <u>-3.225</u>	Sf = <u>0.35</u>
r(w) = <u>0.07726 ft</u>	r(c) = <u>0.2679 ft</u>

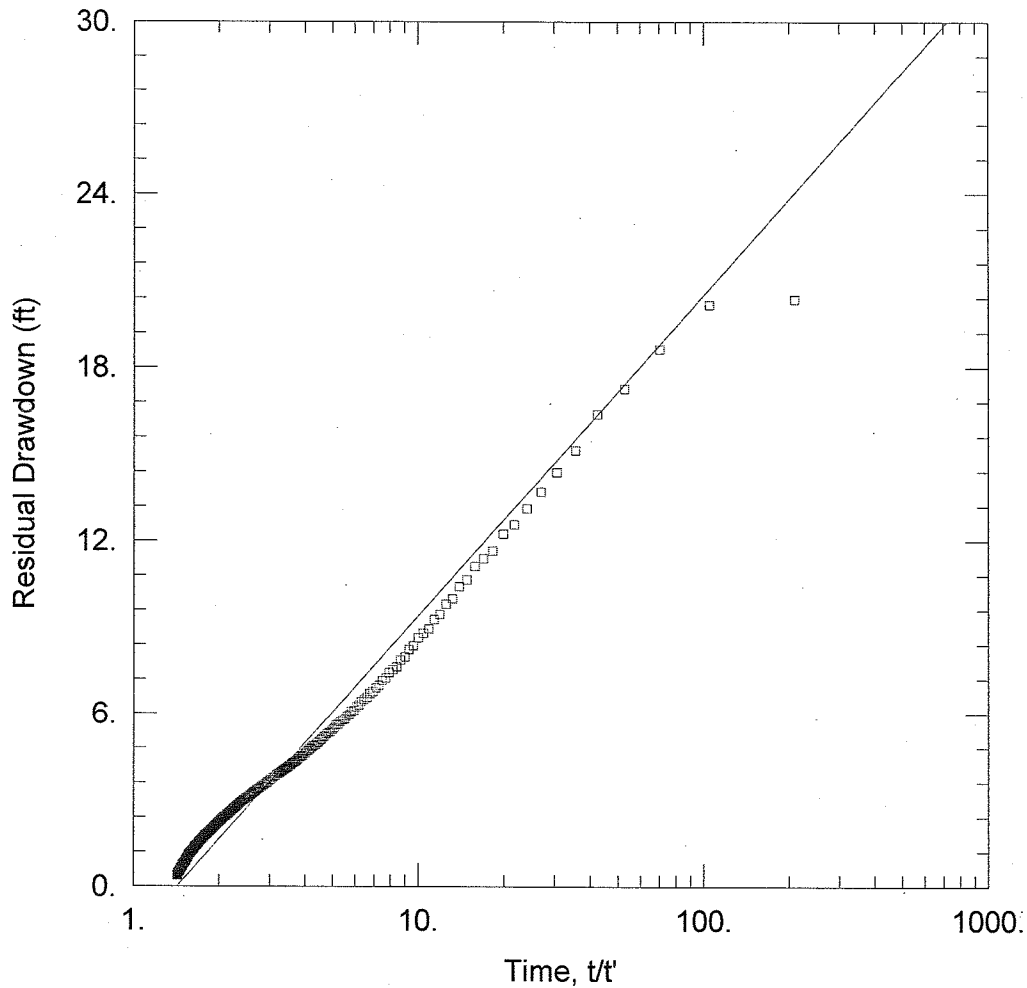

WELL TEST ANALYSIS

Data Set: K:\project\11048\GW\Aqtesolve Files Aquifer Tests\Pw-3 Pump Test AH12-5 Theis rec.aqt
 Date: 08/13/12 Time: 07:00:07

PROJECT INFORMATION

Company: Hydrometrics
 Client: Tintina
 Location: Black Butte
 Test Well: PW-3

AQUIFER DATA

Saturated Thickness: 75. ft Anisotropy Ratio (Kz/Kr): 1.

WELL DATA

Pumping Wells			Observation Wells		
Well Name	X (ft)	Y (ft)	Well Name	X (ft)	Y (ft)
PW-3	0	0	□ SC12-16	775	0

SOLUTION

Aquifer Model: Confined Solution Method: Theis (Recovery)
 T = 85.85 ft²/day S/S' = 1.424

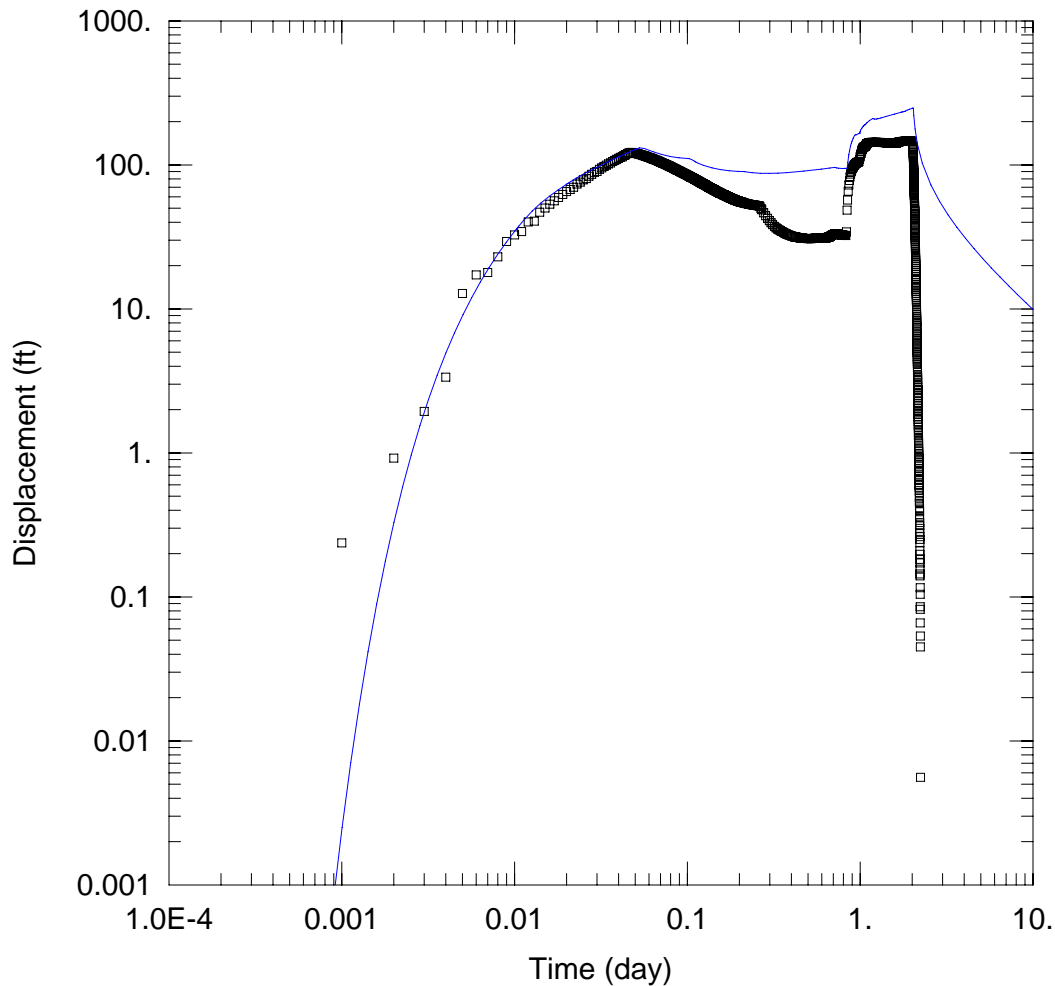

WELL TEST ANALYSIS

Data Set: K:\project\11048\GW\Aqtesolve Files Aquifer Tests\PW-4 Pump Test This.aqt
 Date: 08/27/15 Time: 11:41:16

PROJECT INFORMATION

Company: Hydrometrics
 Client: Tintina
 Location: Black Butte
 Test Well: PW-4

WELL DATA

Pumping Wells			Observation Wells		
Well Name	X (ft)	Y (ft)	Well Name	X (ft)	Y (ft)
Pw-4	0	0	□ Pw-4	0	0

SOLUTION

Aquifer Model: Confined

Solution Method: Thisis

T = 0.7922 ft²/day

S = 0.436

Kz/Kr = 1.

b = 50. ft

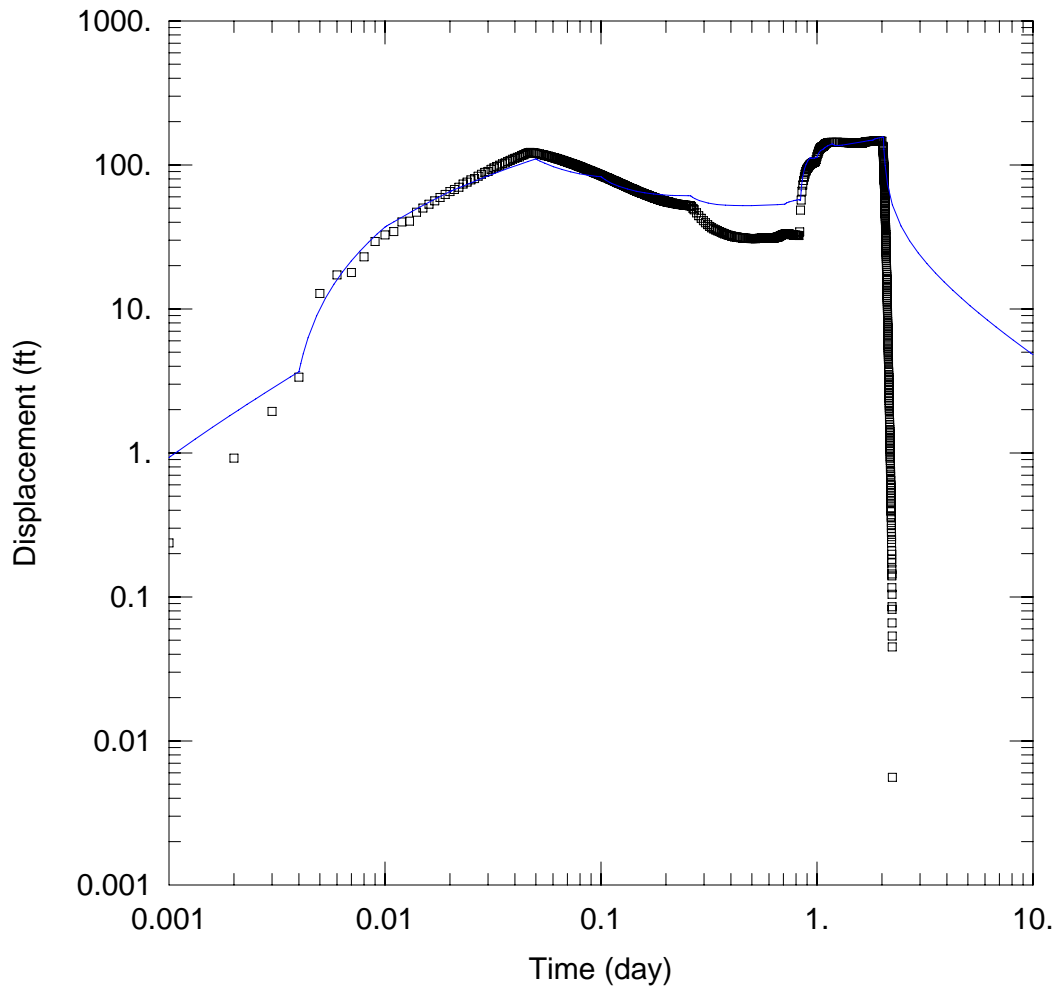

WELL TEST ANALYSIS

Data Set: K:\project\11048\GW\Aqtesolve Files Aquifer Tests\PW-4 Pump Test Moench.aqt
 Date: 08/27/15 Time: 11:50:32

PROJECT INFORMATION

Company: Hydrometrics
 Client: Tintina
 Location: Black Butte
 Test Well: PW-4

AQUIFER DATA

Saturated Thickness: 50. ft Slab Block Thickness: 1. ft

WELL DATA

Pumping Wells			Observation Wells		
Well Name	X (ft)	Y (ft)	Well Name	X (ft)	Y (ft)
PW-4	0.5	0	□ PW-4	0.5	0

SOLUTION

Aquifer Model: <u>Fractured</u>	Solution Method: <u>Moench w/slab blocks</u>
K = <u>0.01334 ft/day</u>	Ss = <u>2.036E-7 ft⁻¹</u>
K' = <u>0.0007792 ft/day</u>	Ss' = <u>0.2627 ft⁻¹</u>
Sw = <u>-0.75</u>	Sf = <u>1.388E-17</u>
r(w) = <u>0.25 ft</u>	r(c) = <u>0.287 ft</u>

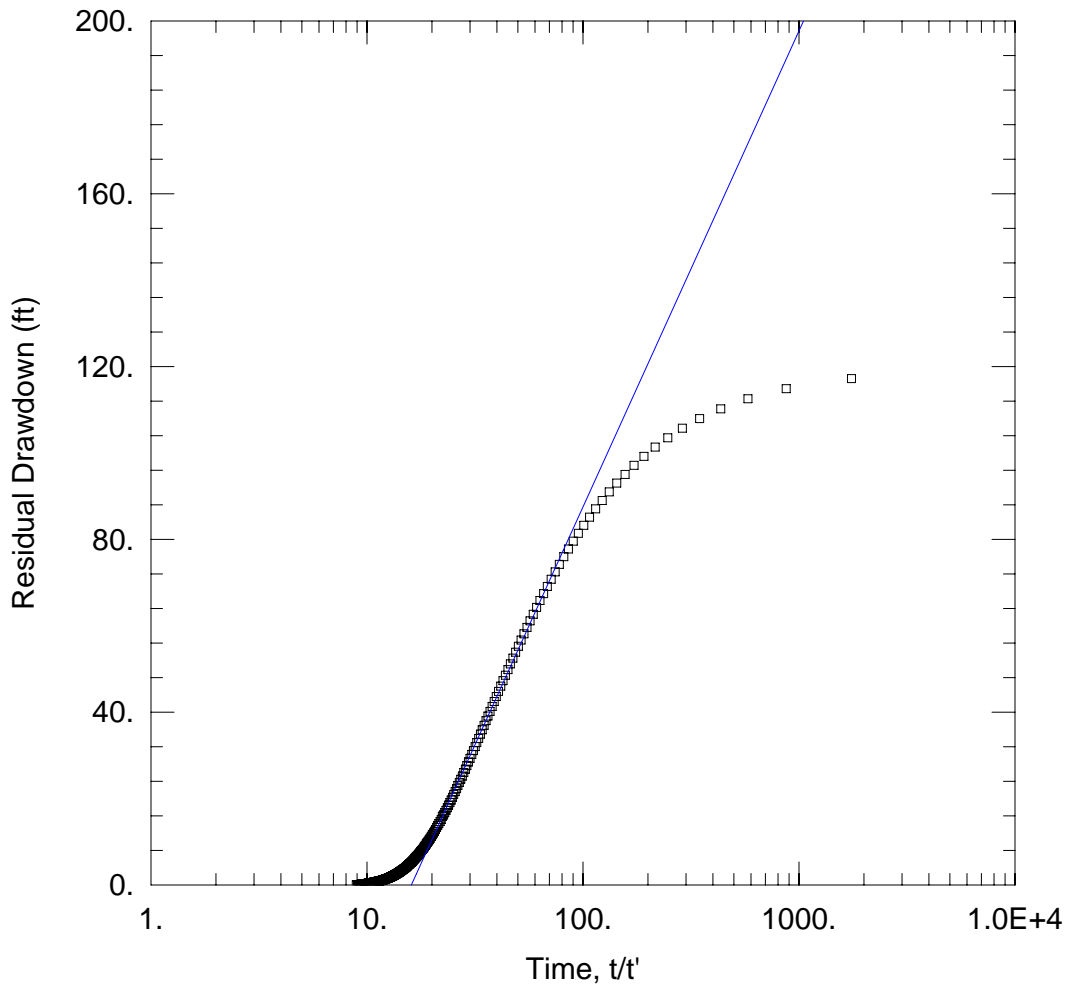

WELL TEST ANALYSIS

Data Set: K:\project\11048\GW\Aqtesolve Files Aquifer Tests\PW-4 Pump Test Theis rec.aqt
 Date: 08/27/15 Time: 11:44:27

PROJECT INFORMATION

Company: Hydrometrics
 Client: Tintina
 Location: Black Butte
 Test Well: PW-4

AQUIFER DATA

Saturated Thickness: 50. ft Anisotropy Ratio (Kz/Kr): 1.

WELL DATA

Pumping Wells			Observation Wells		
Well Name	X (ft)	Y (ft)	Well Name	X (ft)	Y (ft)
PW-4	0.5	0	□ PW-4	0.5	0

SOLUTION

Aquifer Model: Confined Solution Method: Theis (Recovery)
 T = 0.8647 ft²/day S/S' = 16.06

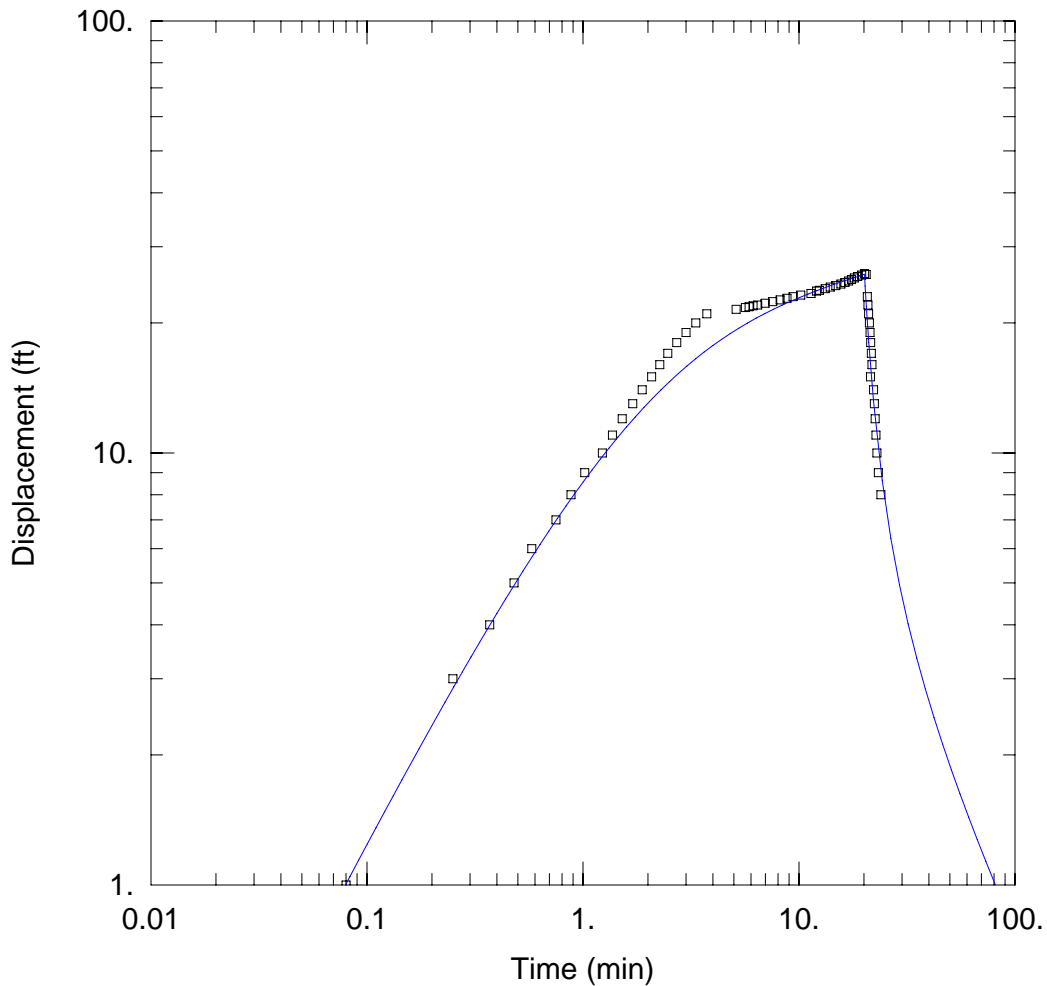

WELL TEST ANALYSIS

Data Set: K:\project\11048\GW\2014GWInv\2014 Aq Tests\PW-5\Analysis\PW-5 Papadopolus.aqt
 Date: 03/12/15 Time: 15:50:06

PROJECT INFORMATION

Company: Hydrometrics
 Client: Tintina
 Project: 11048
 Location: Black Butte
 Test Well: PW-5
 Test Date: 1/7/14

AQUIFER DATA

Saturated Thickness: 50. ft Anisotropy Ratio (Kz/Kr): 1.

WELL DATA

Pumping Wells			Observation Wells		
Well Name	X (ft)	Y (ft)	Well Name	X (ft)	Y (ft)
PW-5	0	0	□ PW-5	0	0

SOLUTION

Aquifer Model: Confined Solution Method: Papadopolus-Cooper
 $T = 4.627 \text{ ft}^2/\text{day}$ $S = 0.0001644$
 $r(w) = 0.5345 \text{ ft}$ $r(c) = 0.1 \text{ ft}$

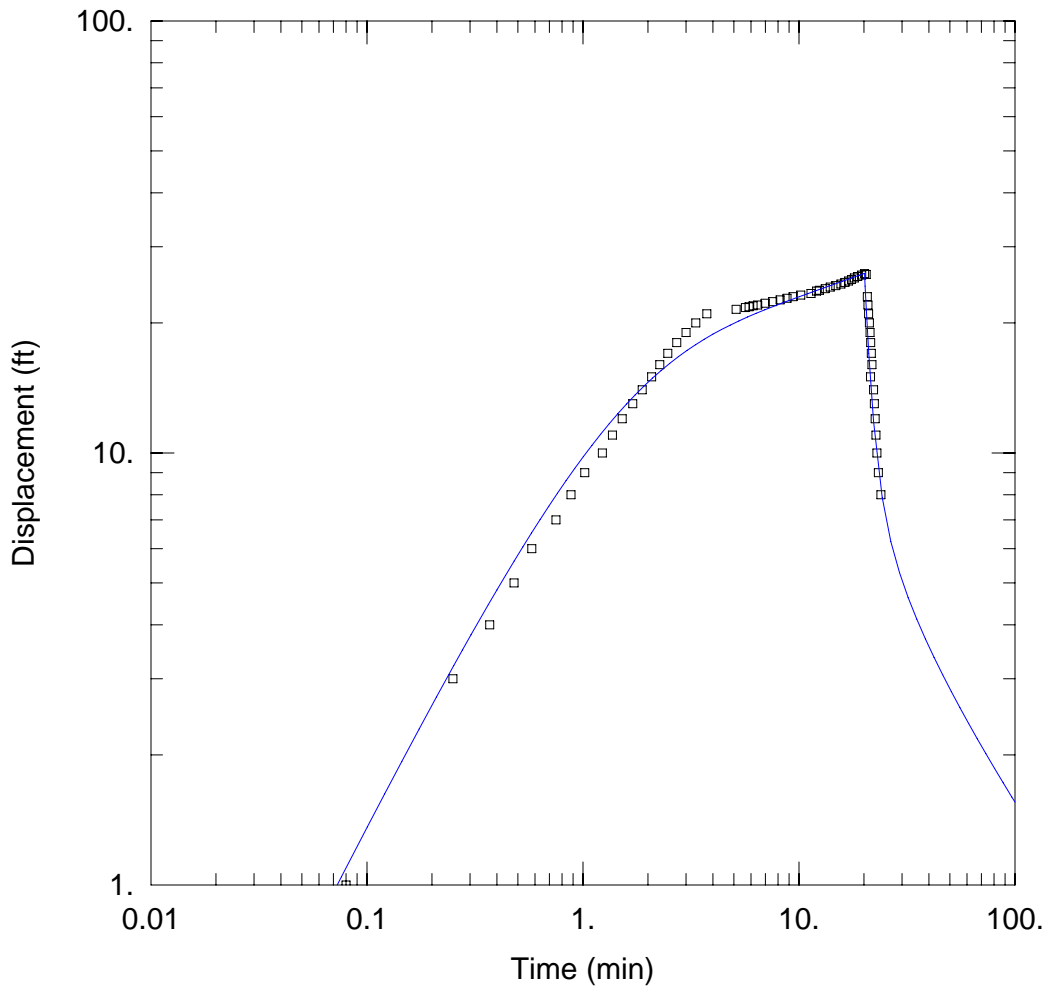

WELL TEST ANALYSIS

Data Set: K:\project\11048\GW\2014GWInv\2014 Aq Tests\PW-5\Analysis\PW-5 Moench.aqt
 Date: 03/30/15 Time: 07:20:33

PROJECT INFORMATION

Company: Hydrometrics
 Client: Tintina
 Project: 11048
 Location: Black Butte
 Test Well: PW-5
 Test Date: 1/7/14

AQUIFER DATA

Saturated Thickness: 50. ft Anisotropy Ratio (Kz/Kr): 1.

WELL DATA

Pumping Wells			Observation Wells		
Well Name	X (ft)	Y (ft)	Well Name	X (ft)	Y (ft)
PW-5	0	0	□ PW-5	0	0

SOLUTION

Aquifer Model: <u>Fractured</u>	Solution Method: <u>Barker</u>
K = <u>0.01505 ft/day</u>	Ss = <u>0.0002546</u>
K' = <u>0.0005 ft/day</u>	Ss' = <u>5.377E-8 ft⁻¹</u>
n = <u>1.475</u>	b = <u>50. ft</u>
Sf = <u>3.5</u>	Sw = <u>3.25</u>
r(w) = <u>0.3333 ft</u>	r(c) = <u>0.05482 ft</u>

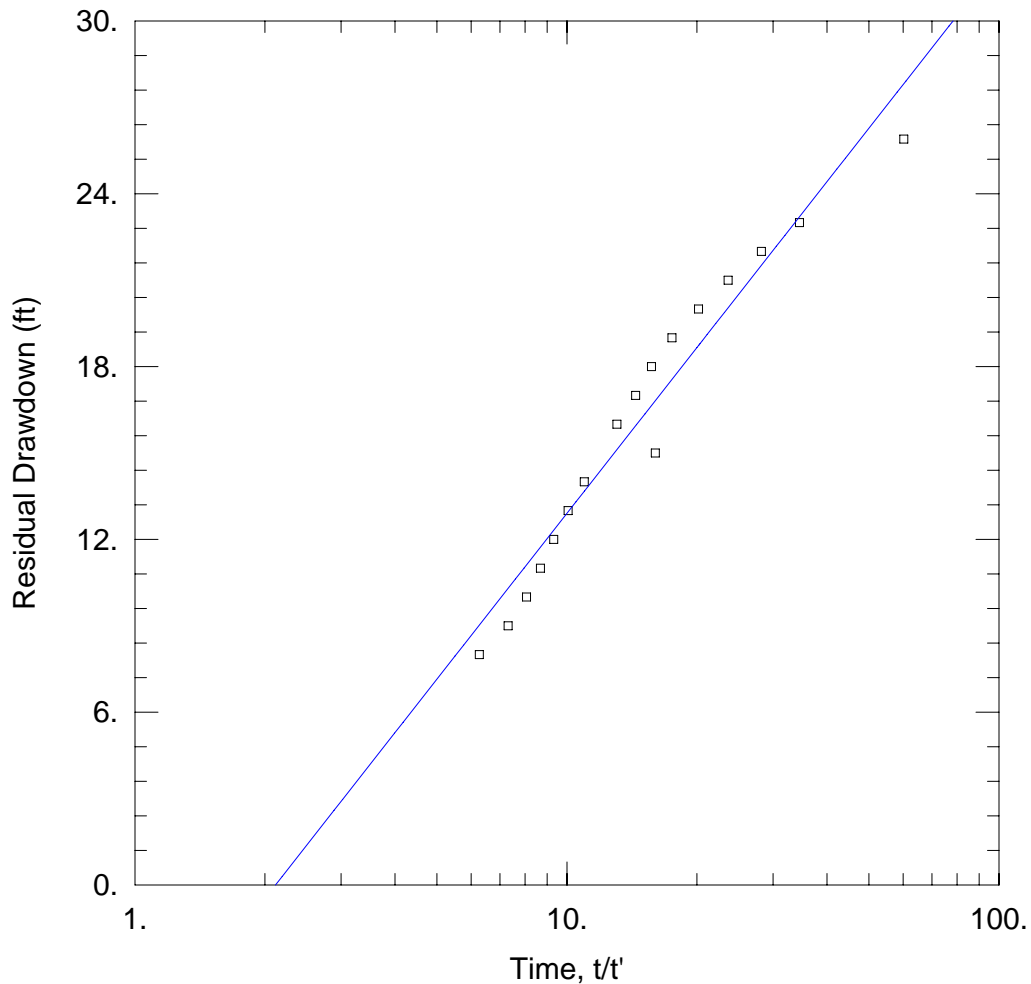

WELL TEST ANALYSIS

Data Set: K:\project\11048\GW\2014GWInv\2014 Aq Tests\PW-5\Analysis\PW-5 Theis Recovery.aqt
 Date: 08/27/15 Time: 11:53:23

PROJECT INFORMATION

Company: Hydrometrics
 Client: Tintina
 Project: 11048
 Location: Black Butte
 Test Well: PW-5
 Test Date: 1/7/14

AQUIFER DATA

Saturated Thickness: 50. ft Anisotropy Ratio (Kz/Kr): 1.

WELL DATA

Pumping Wells			Observation Wells		
Well Name	X (ft)	Y (ft)	Well Name	X (ft)	Y (ft)
PW-5	0	0	□ PW-5	0	0

SOLUTION

Aquifer Model: Confined Solution Method: Theis (Recovery)
 $T = 1.844 \text{ ft}^2/\text{day}$ $S/S' = 2.116$

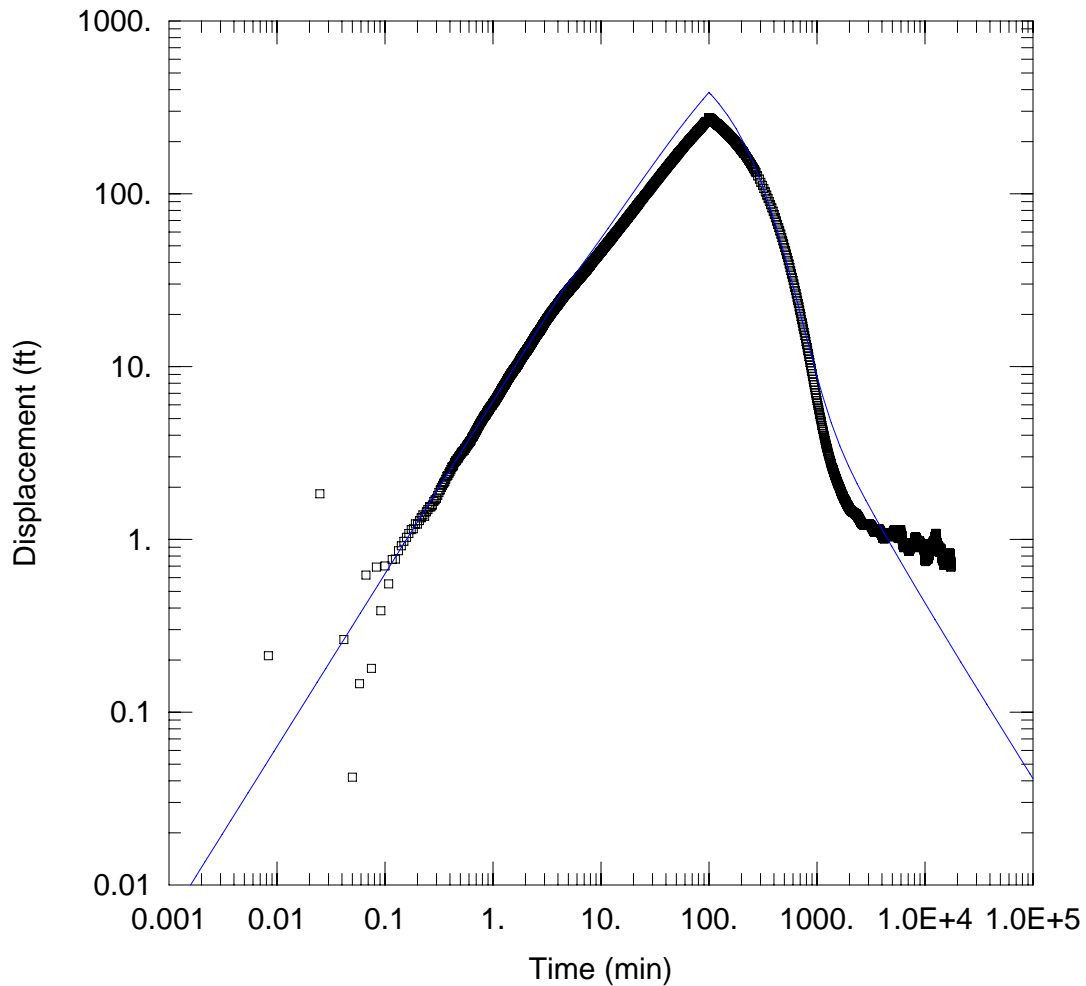

WELL TEST ANALYSIS

Data Set: K:\project\11048\GW\2014GWInv\2014 Aq Tests\PW-6\AQTESOLV\PW-6 Papadopoulos.aqt
 Date: 03/12/15 Time: 12:44:35

PROJECT INFORMATION

Company: Hydrometrics
 Client: Tintina
 Project: 11048
 Location: Black Butte
 Test Well: PW-6
 Test Date: 10/17/14

AQUIFER DATA

Saturated Thickness: 50. ft Anisotropy Ratio (Kz/Kr): 0.001462

WELL DATA

Pumping Wells			Observation Wells		
Well Name	X (ft)	Y (ft)	Well Name	X (ft)	Y (ft)
PW-6	0	0	□ PW-6	0	0

SOLUTION

Aquifer Model: Confined Solution Method: Papadopoulos-Cooper
 $T = 1.883 \text{ ft}^2/\text{day}$ $S = 5.421\text{E-}9$
 $r(w) = 0.25 \text{ ft}$ $r(c) = 0.2177 \text{ ft}$

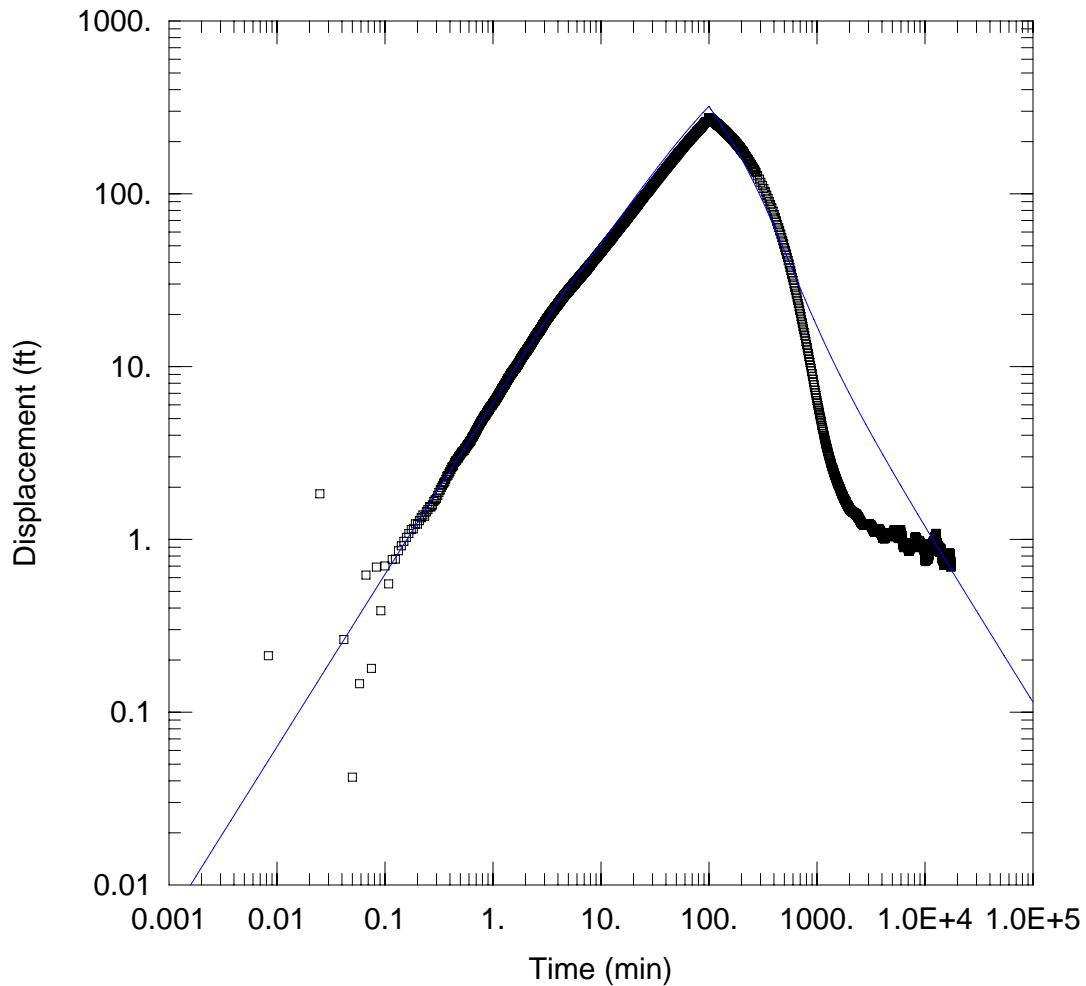

WELL TEST ANALYSIS

Data Set: K:\project\11048\GW\2014GWInv\2014 Aq Tests\PW-6\AQTESOLV\PW-6 Moench.aqt
 Date: 03/12/15 Time: 12:45:45

PROJECT INFORMATION

Company: Hydrometrics
 Client: Tintina
 Project: 11048
 Location: Black Butte
 Test Well: PW-6
 Test Date: 10/17/14

AQUIFER DATA

Saturated Thickness: 50. ft Slab Block Thickness: 1. ft

WELL DATA

Pumping Wells			Observation Wells		
Well Name	X (ft)	Y (ft)	Well Name	X (ft)	Y (ft)
PW-6	0	0	□ PW-6	0	0

SOLUTION

Aquifer Model: Fractured

Solution Method: Moench w/slab blocks

K = 0.01358 ft/day
 K' = 2.282E-6 ft/day
 Sw = -0.525
 r(w) = 0.1253 ft

Ss = 0.0002495 ft⁻¹
 Ss' = 2.738E-9 ft⁻¹
 Sf = 4.9
 r(c) = 0.2177 ft

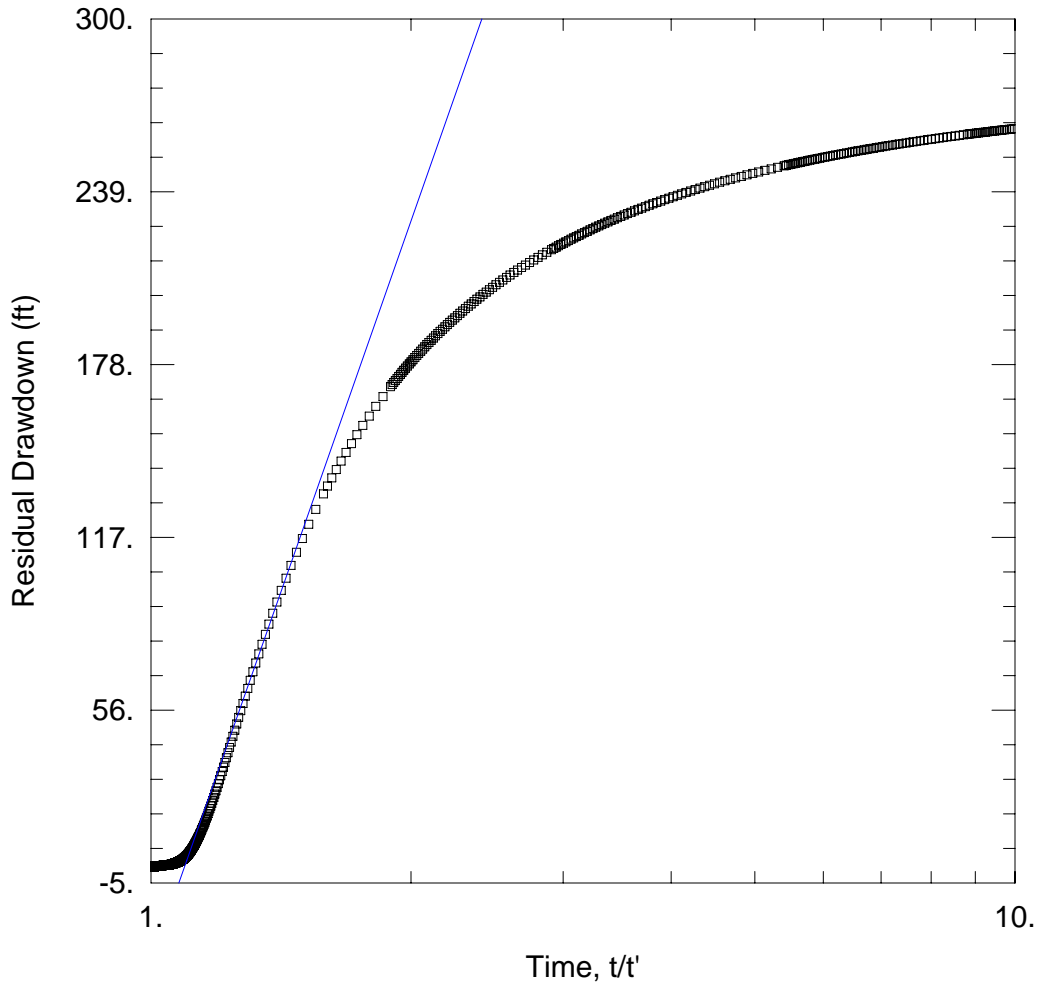

WELL TEST ANALYSIS

Data Set: K:\project\11048\GW\2014GWInv\2014 Aq Tests\PW-6\AQTESOLV\PW-6 Theis-Rec.aqt
 Date: 03/12/15 Time: 12:41:30

PROJECT INFORMATION

Company: Hydrometrics
 Client: Tintina
 Project: 11048
 Location: Black Butte
 Test Well: PW-6
 Test Date: 10/17/14

AQUIFER DATA

Saturated Thickness: 50. ft Anisotropy Ratio (Kz/Kr): 0.001462

WELL DATA

Pumping Wells			Observation Wells		
Well Name	X (ft)	Y (ft)	Well Name	X (ft)	Y (ft)
PW-6	0	0	□ PW-6	0	0

SOLUTION

Aquifer Model: Confined Solution Method: Theis (Recovery)
 T = 0.2028 ft²/day S/S' = 1.092

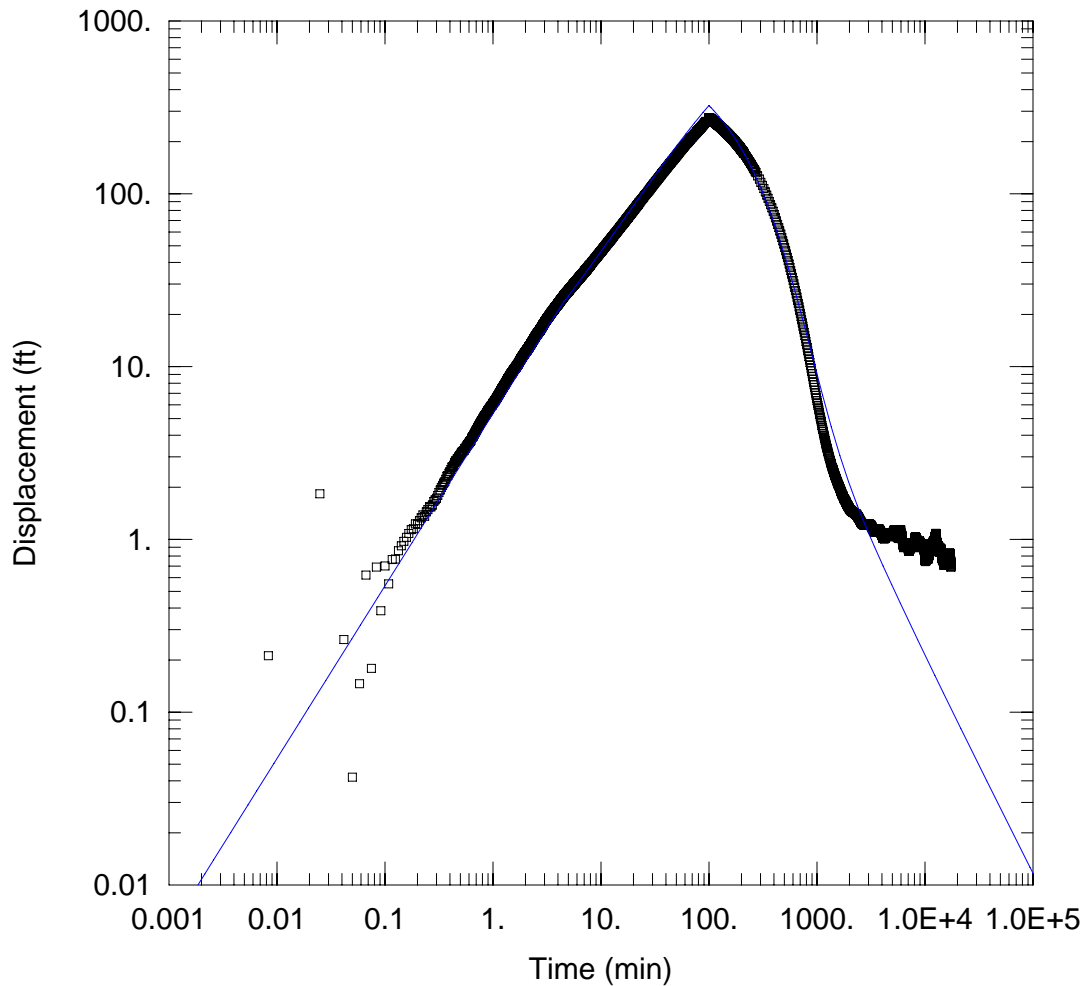

WELL TEST ANALYSIS

Data Set: K:\project\11048\GW\2014GWInv\2014 Aq Tests\PW-6\AQTESOLV\PW-6 Barker.aqt
 Date: 03/12/15 Time: 12:43:13

PROJECT INFORMATION

Company: Hydrometrics
 Client: Tintina
 Project: 11048
 Location: Black Butte
 Test Well: PW-6
 Test Date: 10/17/14

AQUIFER DATA

Saturated Thickness: 50. ft Anisotropy Ratio (Kz/Kr): 0.001462

WELL DATA

Pumping Wells			Observation Wells		
Well Name	X (ft)	Y (ft)	Well Name	X (ft)	Y (ft)
PW-6	0	0	□ PW-6	0	0

SOLUTION

Aquifer Model: <u>Fractured</u>	Solution Method: <u>Barker</u>
K = <u>0.06202 ft/day</u>	Ss = <u>0.0009054</u>
K' = <u>2.282E-6 ft/day</u>	Ss' = <u>2.738E-9 ft⁻¹</u>
n = <u>2.48</u>	b = <u>50. ft</u>
Sf = <u>4.9</u>	Sw = <u>-0.525</u>
r(w) = <u>0.1253 ft</u>	r(c) = <u>0.2177 ft</u>

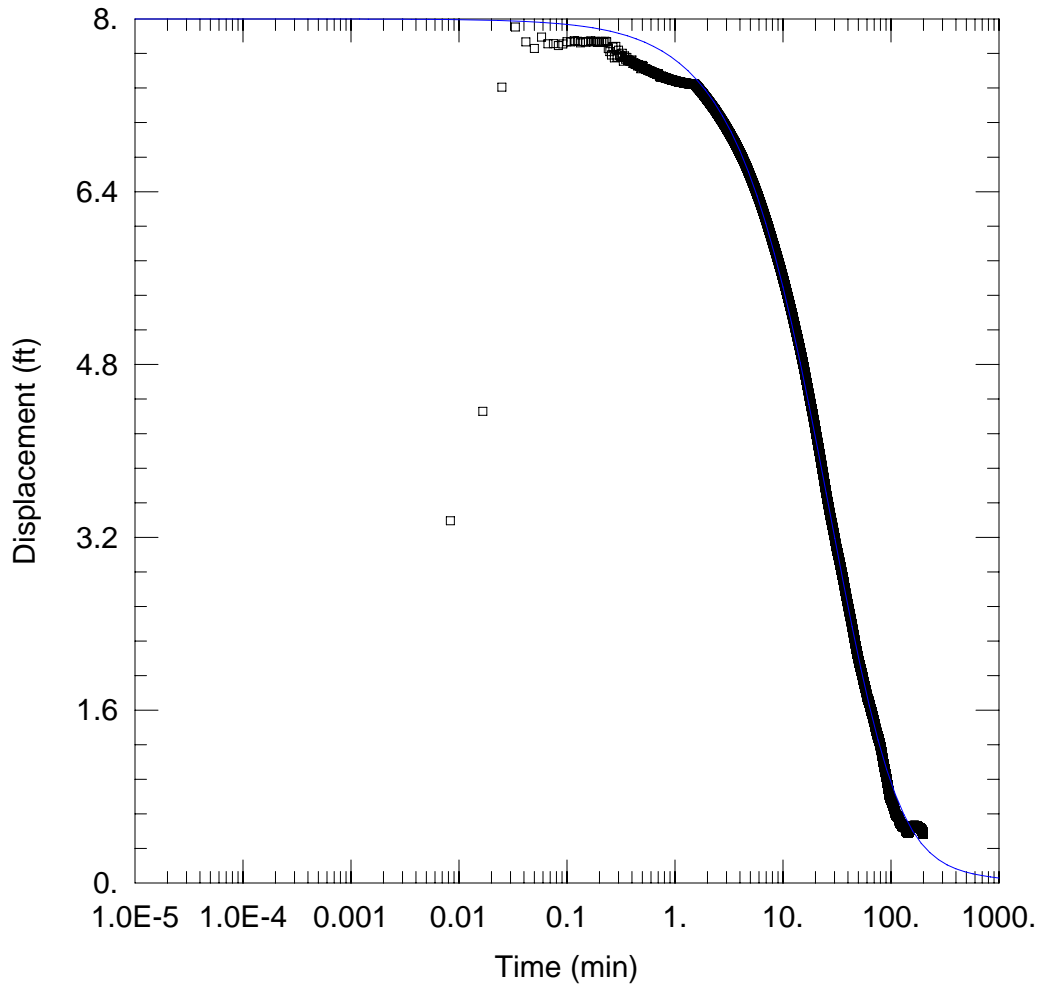

WELL TEST ANALYSIS

Data Set: K:\project\11048\GW\2014GWInv\2014 Aq Tests\PW-7 Slug Test\AQTESOLV\PW-7_Barker-Black.aqt
 Date: 03/12/15 Time: 12:47:29

PROJECT INFORMATION

Company: Hydrometrics
 Client: Tintina
 Project: 11048
 Location: Black Butte
 Test Well: PW-7
 Test Date: 10/17/14

AQUIFER DATA

Saturated Thickness: 50. ft Anisotropy Ratio (Kz/Kr): 1.

WELL DATA (PW-7)

Initial Displacement: 8. ft Static Water Column Height: 1346. ft
 Total Well Penetration Depth: 1346. ft Screen Length: 40. ft
 Casing Radius: 0.25 ft Well Radius: 0.25 ft
 Gravel Pack Porosity: 0.

SOLUTION

Aquifer Model: Fractured Solution Method: Barker-Black
 $T = 4.351 \text{ ft}^2/\text{day}$ $S = 7.674\text{E-}6$
 $K' = 1.413\text{E-}6 \text{ ft/day}$ $Ss' = 8.913\text{E-}5 \text{ ft}^{-1}$

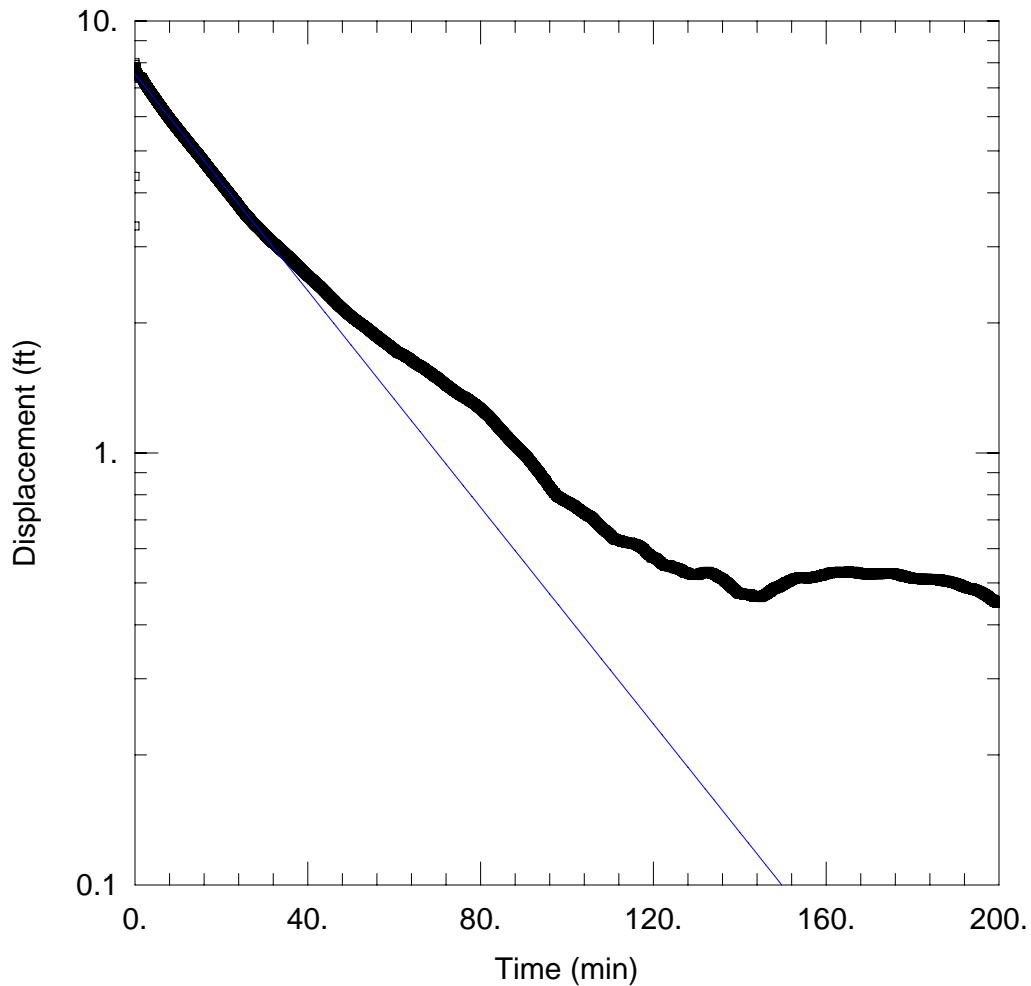

WELL TEST ANALYSIS

Data Set: K:\project\11048\GW\2014GW\Inv\2014 Aq Tests\PW-7 Slug Test\AQTESOLV\PW-7_Hvorslev.aqt
 Date: 03/12/15 Time: 12:49:05

PROJECT INFORMATION

Company: Hydrometrics
 Client: Tintina
 Project: 11048
 Location: Black Butte
 Test Well: PW-7
 Test Date: 10/17/14

AQUIFER DATA

Saturated Thickness: 50. ft Anisotropy Ratio (Kz/Kr): 1.

WELL DATA (PW-7)

Initial Displacement: 8. ft Static Water Column Height: 1346. ft
 Total Well Penetration Depth: 1346. ft Screen Length: 40. ft
 Casing Radius: 0.25 ft Well Radius: 0.25 ft
 Gravel Pack Porosity: 0.

SOLUTION

Aquifer Model: Confined Solution Method: Bouwer-Rice
 K = 0.1961 ft/day y0 = 7.526 ft

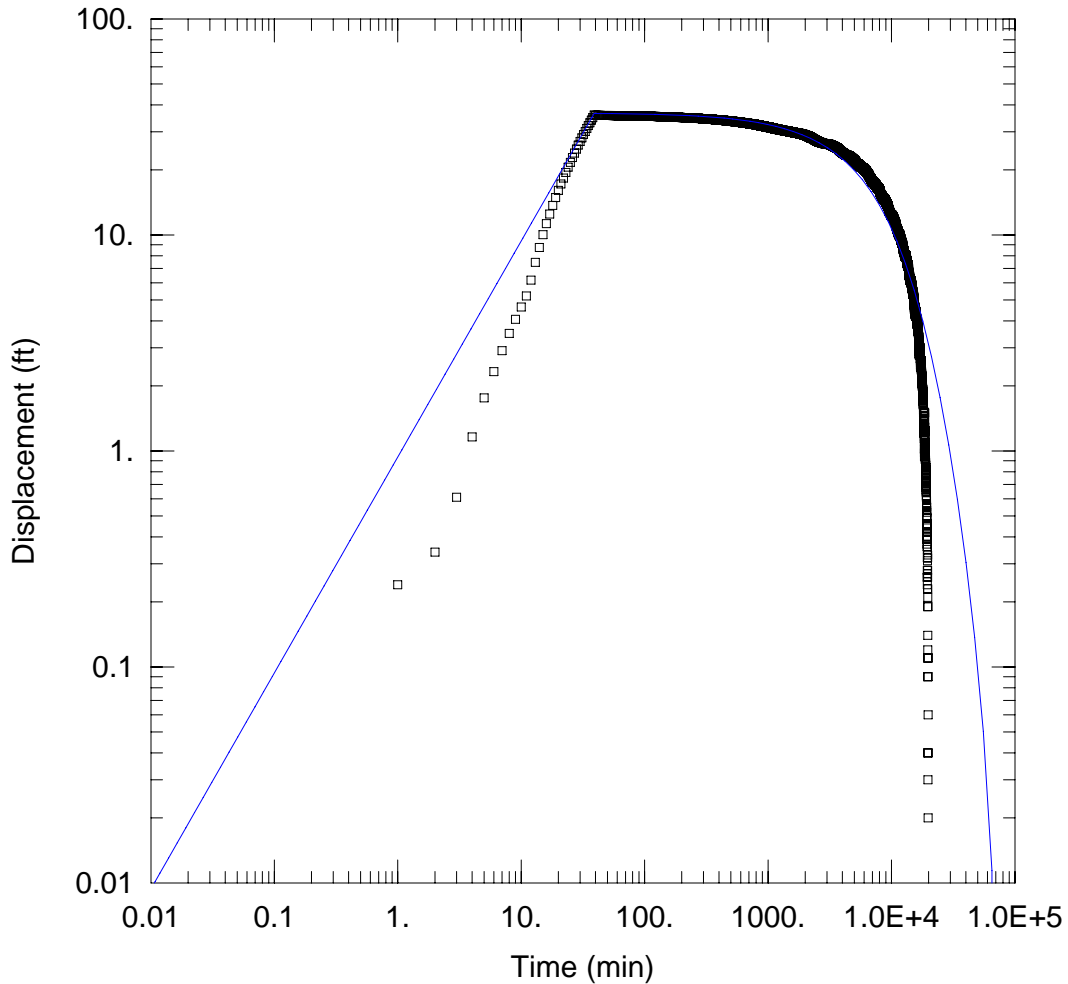

WELL TEST ANALYSIS

Data Set: K:\project\11048\Baseline WRM Report\Appendices\Appendix D - AqTest Analyses\PW7_Moench.aqt
 Date: 08/25/15 Time: 08:15:34

PROJECT INFORMATION

Company: Hydrometrics
 Client: Tintina
 Project: 11048
 Location: Black Butte
 Test Well: PW-7
 Test Date: 3/24/15

AQUIFER DATA

Saturated Thickness: 50 ft Slab Block Thickness: 1 ft

WELL DATA

Pumping Wells			Observation Wells		
Well Name	X (ft)	Y (ft)	Well Name	X (ft)	Y (ft)
PW-7	0	0	□ PW-7	0	0

SOLUTION

Aquifer Model: Fractured
 K = 0.0003164 ft/day
 K' = 2.279E-5 ft/day
 Sw = -4.775
 r(w) = 0.25 ft

Solution Method: Moench w/slab blocks
 Ss = 2.132E-15 ft⁻¹
 Ss' = 0.004467 ft⁻¹
 Sf = 10
 r(c) = 0.2333 ft

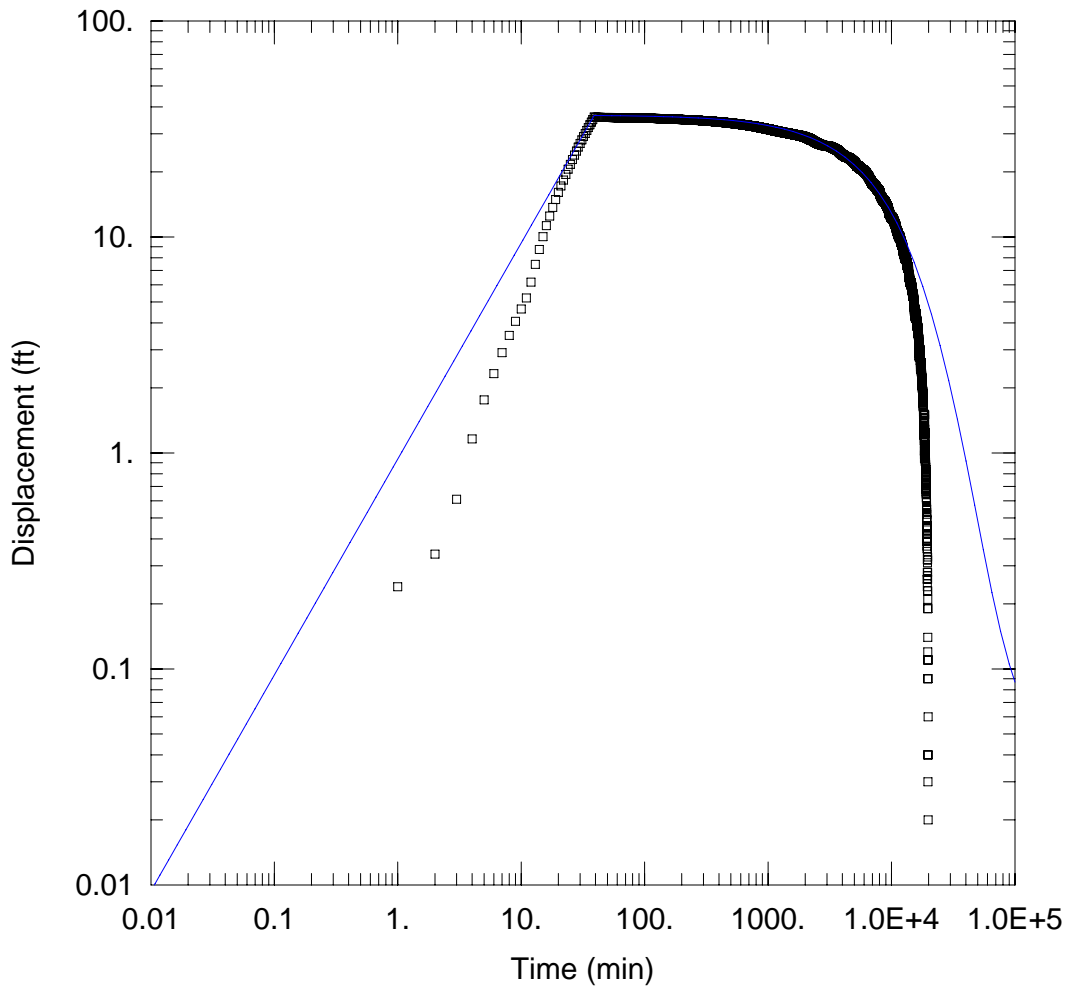

WELL TEST ANALYSIS

Data Set: K:\project\11048\Baseline WRM Report\Appendices\Appendix D - AqTest Analyses\PW7_Barker.aqt
 Date: 08/25/15 Time: 08:16:57

PROJECT INFORMATION

Company: Hydrometrics
 Client: Tintina
 Project: 11048
 Location: Black Butte
 Test Well: PW-7
 Test Date: 3/24/15

AQUIFER DATA

Saturated Thickness: 50. ft Anisotropy Ratio (Kz/Kr): 1.

WELL DATA

Pumping Wells			Observation Wells		
Well Name	X (ft)	Y (ft)	Well Name	X (ft)	Y (ft)
PW-7	0	0	□ PW-7	0	0

SOLUTION

Aquifer Model: <u>Fractured</u>	Solution Method: <u>Barker</u>
K = <u>0.001043</u> ft/day	Ss = <u>4.993E-13</u>
K' = <u>3.224E-7</u> ft/day	Ss' = <u>3.162E-10</u> ft ⁻¹
n = <u>2.1</u>	b = <u>50.</u> ft
Sf = <u>4.9</u>	Sw = <u>1.825</u>
r(w) = <u>0.25</u> ft	r(c) = <u>0.2333</u> ft

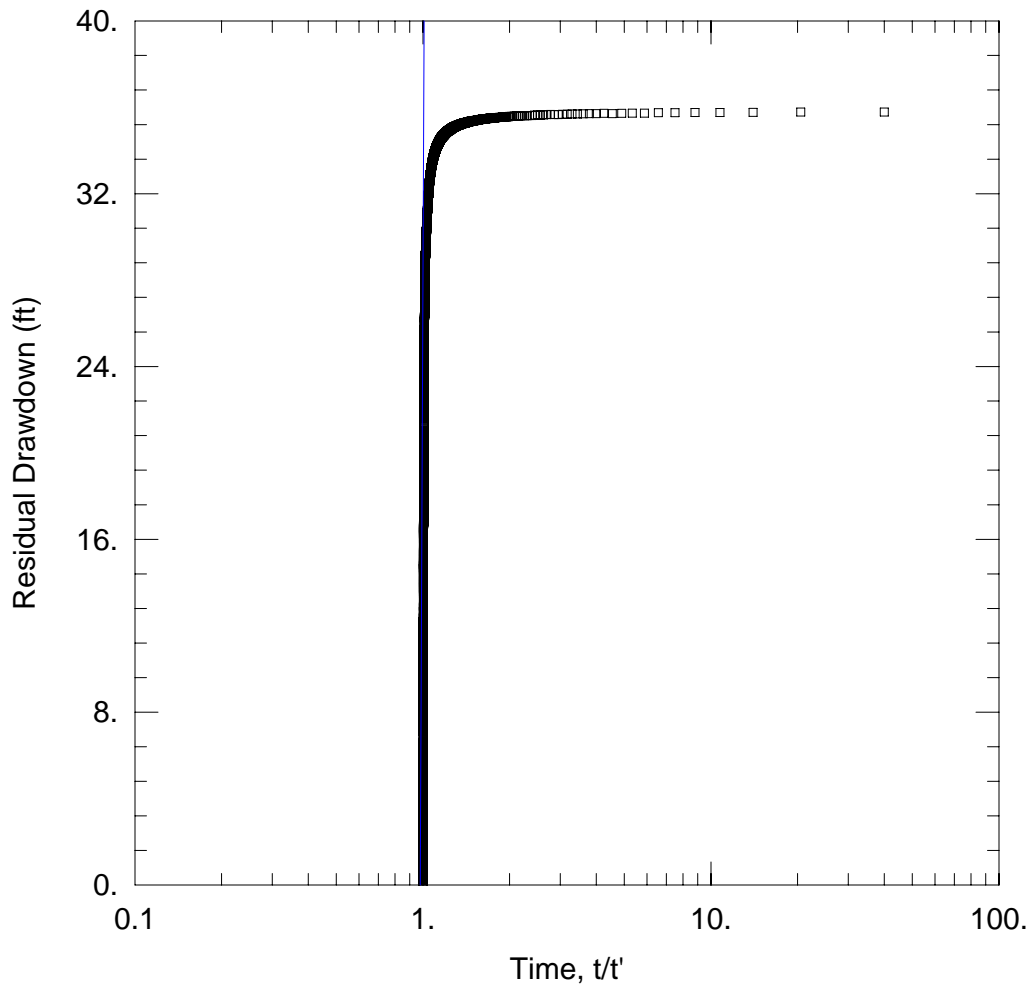

WELL TEST ANALYSIS

Data Set: K:\...\PW7_TheisRec.aqt
 Date: 08/25/15

Time: 08:22:58

PROJECT INFORMATION

Company: Hydrometrics
 Client: Tintina
 Project: 11048
 Location: Black Butte
 Test Well: PW-7
 Test Date: 3/24/15

AQUIFER DATA

Saturated Thickness: 50 ft

Anisotropy Ratio (Kz/Kr): 1

WELL DATA

Pumping Wells

Well Name	X (ft)	Y (ft)
PW-7	0	0

Observation Wells

Well Name	X (ft)	Y (ft)
□ PW-7	0	0

SOLUTION

Aquifer Model: Confined

Solution Method: Theis (Recovery)

T = 0.01405 ft²/day

S/S' = 0.9787

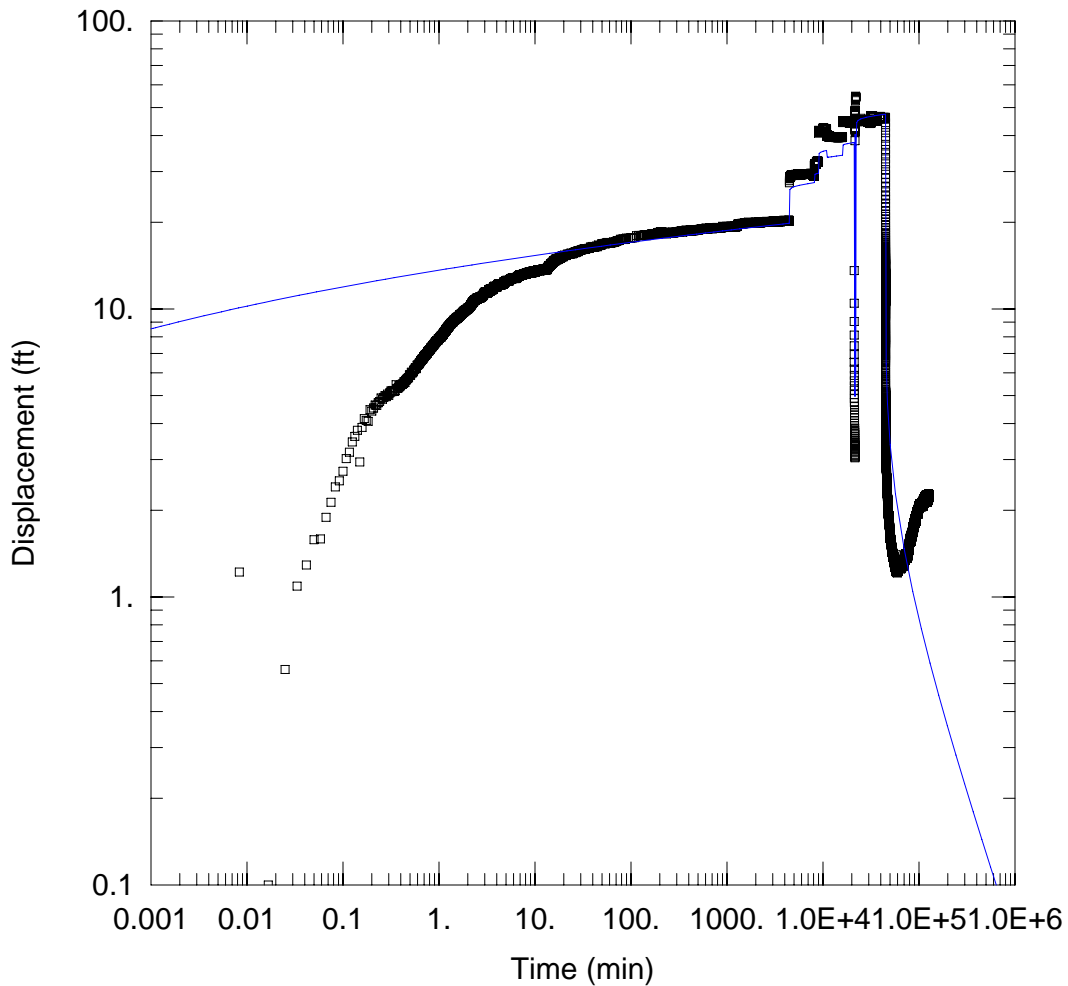

WELL TEST ANALYSIS

Data Set: K:\project\11048\GW\2014GWInv\2014 Aq Tests\PW-8\Analysis\PW-8 Theis.aqt
 Date: 03/12/15 Time: 12:58:15

PROJECT INFORMATION

Company: Hydrometrics
 Client: Tintina
 Project: 11048
 Location: Black Butte Copper
 Test Well: PW-8

WELL DATA

Pumping Wells			Observation Wells		
Well Name	X (ft)	Y (ft)	Well Name	X (ft)	Y (ft)
PW-8	1662868.983	16996825.89	□ PW-8	1662868.983	16996825.89

SOLUTION

Aquifer Model: Confined Solution Method: Theis
 T = 114. ft²/day S = 7.251E-8
 Kz/Kr = 1. b = 50. ft

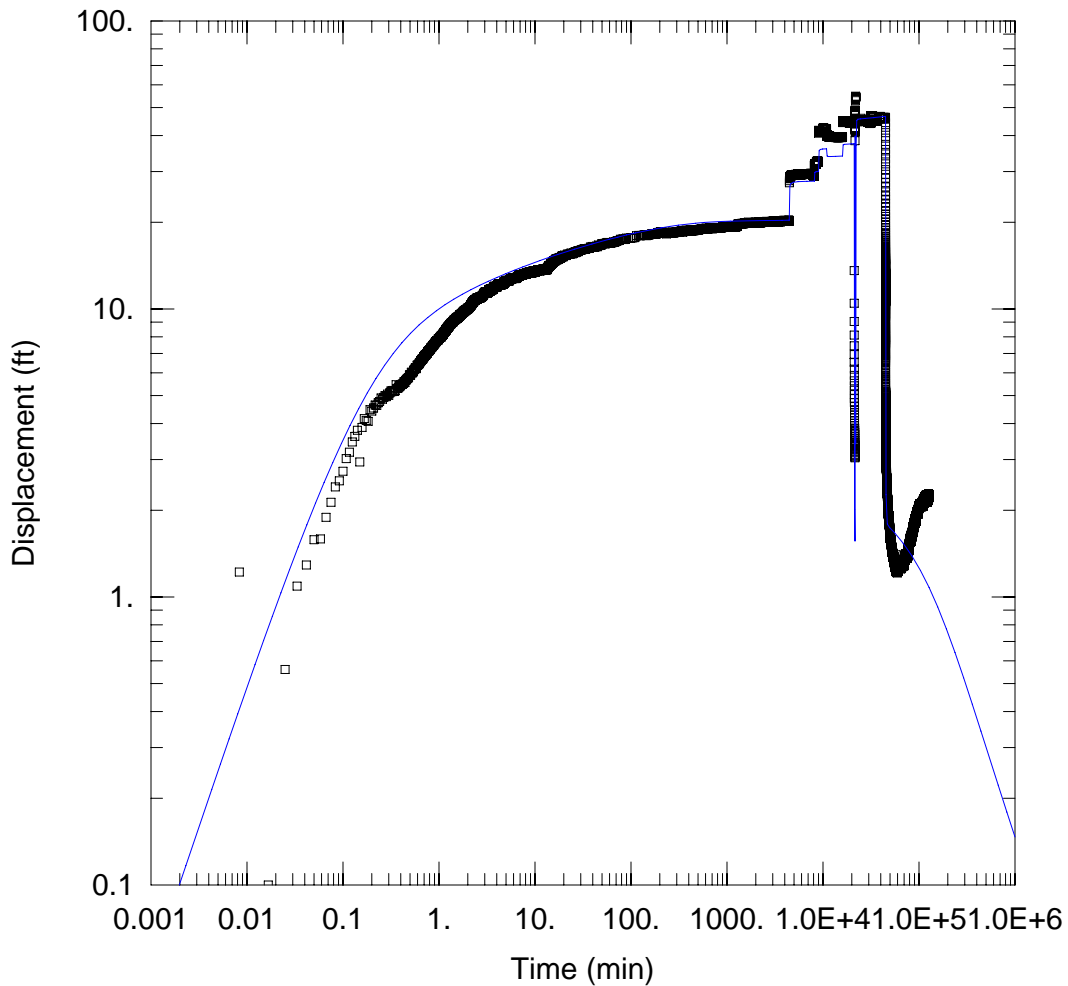

WELL TEST ANALYSIS

Data Set: K:\project\11048\GW\2014GWInv\2014 Aq Tests\PW-8\Analysis\PW-8_moench.aqt
 Date: 08/27/15 Time: 11:57:42

PROJECT INFORMATION

Company: Hydrometrics
 Client: Tintina
 Project: 11048
 Location: Black Butte Copper
 Test Well: PW-8

AQUIFER DATA

Saturated Thickness: 50. ft Slab Block Thickness: 1. ft

WELL DATA

Pumping Wells			Observation Wells		
Well Name	X (ft)	Y (ft)	Well Name	X (ft)	Y (ft)
PW-8	1662868.983	16996825.89	□ PW-8	1662868.983	16996825.89

SOLUTION

Aquifer Model: Fractured

Solution Method: Moench w/slab blocks

K = 0.9804 ft/day
 K' = 0.008788 ft/day
 Sw = 1.075
 r(w) = 0.1549 ft

Ss = 0.001109 ft⁻¹
 Ss' = 0.1663 ft⁻¹
 Sf = 9.85
 r(c) = 0.06763 ft

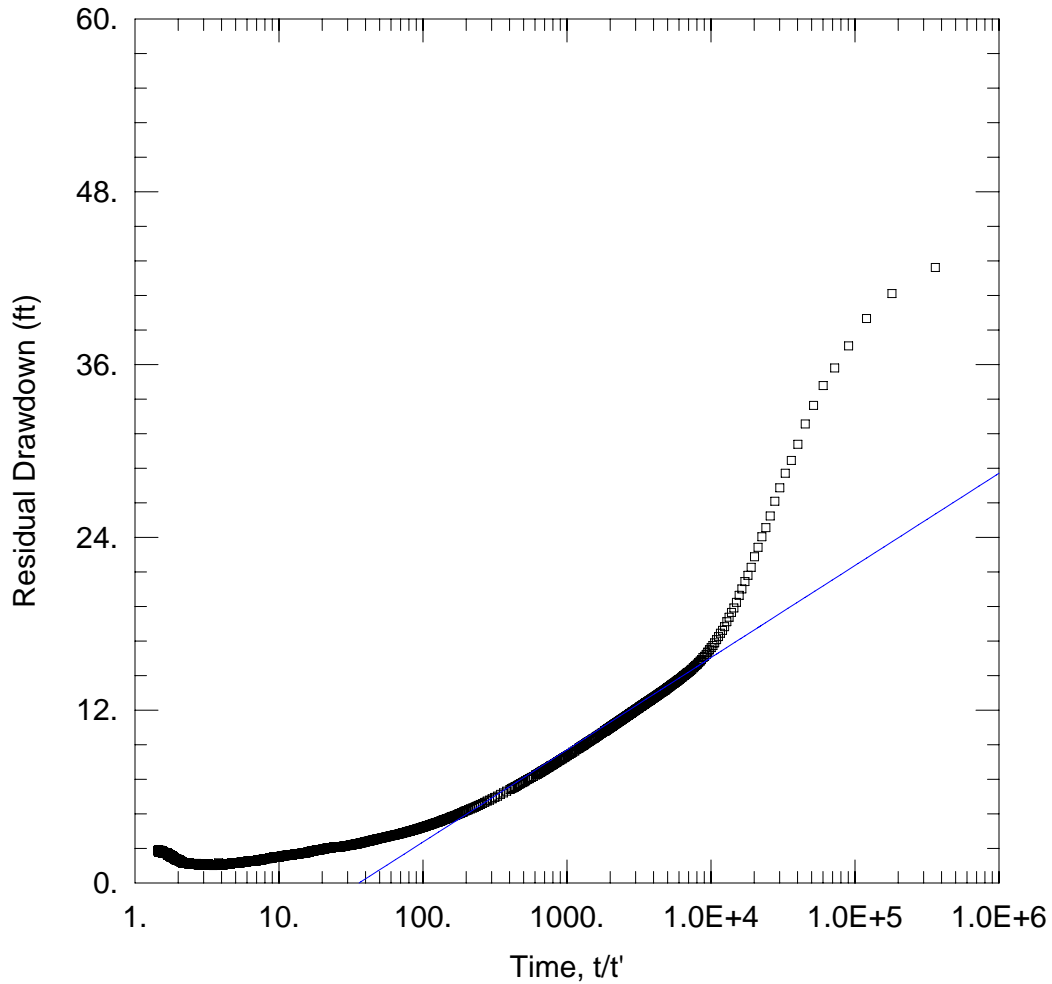

WELL TEST ANALYSIS

Data Set: K:\project\11048\GW\2014GWInv\2014 Aq Tests\PW-8\Analysis\PW-8 Theis_Rec.aqt
 Date: 03/12/15 Time: 12:56:26

PROJECT INFORMATION

Company: Hydrometrics
 Client: Tintina
 Project: 11048
 Location: Black Butte Copper
 Test Well: PW-8

AQUIFER DATA

Saturated Thickness: 40. ft Anisotropy Ratio (Kz/Kr): 1.

WELL DATA

Pumping Wells			Observation Wells		
Well Name	X (ft)	Y (ft)	Well Name	X (ft)	Y (ft)
PW-8	1662868.983	16996825.89	□ PW-8	1662868.983	16996825.89

SOLUTION

Aquifer Model: Confined Solution Method: Theis (Recovery)
 $T = \underline{67.22}$ ft²/day $S/S' = \underline{36.07}$

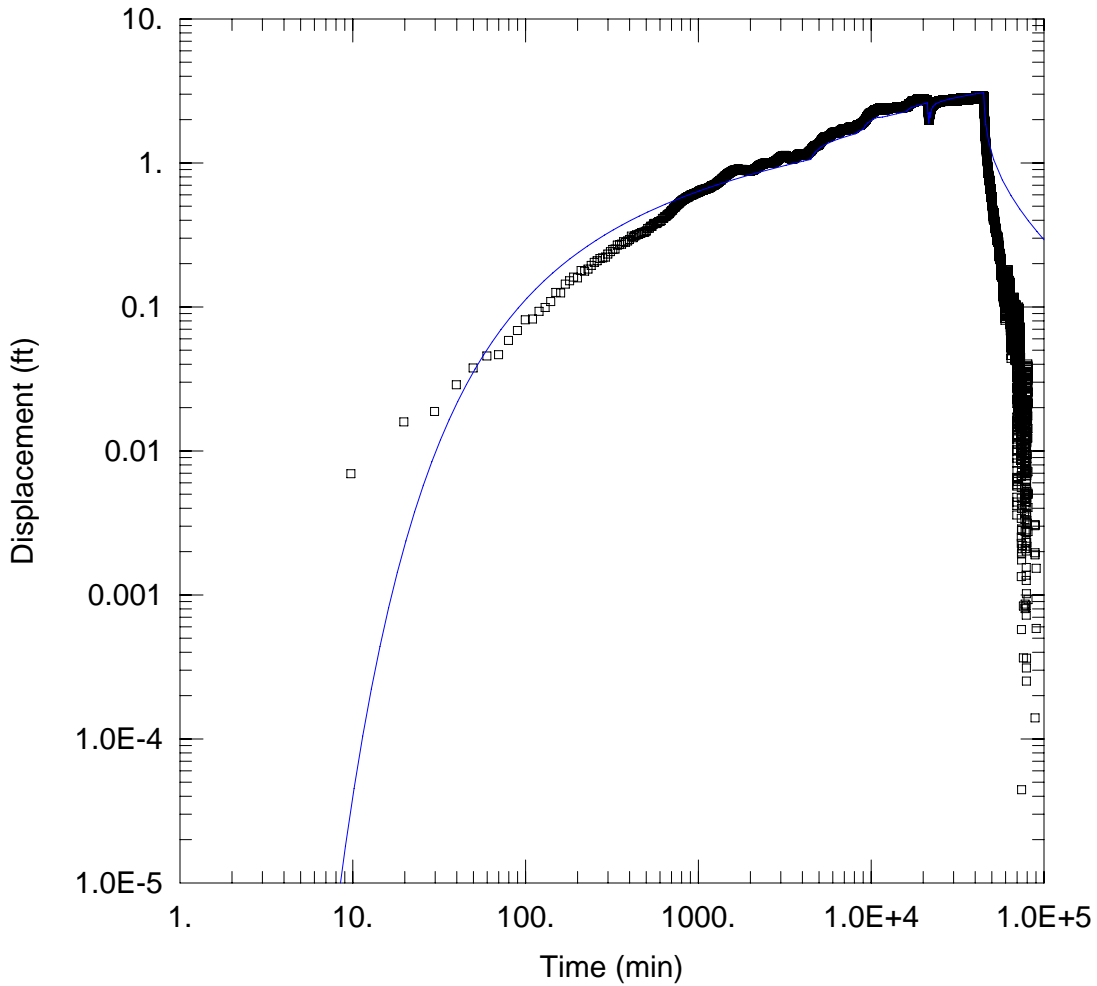

WELL TEST ANALYSIS

Data Set: K:\project\11048\GW\2014GWInv\2014 Aq Tests\PW-8\Analysis\PW-3 Theis.aqt
 Date: 03/12/15 Time: 13:02:45

PROJECT INFORMATION

Company: Hydrometrics
 Client: Tintina
 Project: 11048
 Location: Black Butte Copper
 Test Well: PW-8

WELL DATA

Pumping Wells			Observation Wells		
Well Name	X (ft)	Y (ft)	Well Name	X (ft)	Y (ft)
PW-8	1662868.983	16996825.89	□ PW-3	1662824.51	16996177.15

SOLUTION

Aquifer Model: Confined Solution Method: Theis
 T = 288. ft²/day S = 0.0001298
 Kz/Kr = 1. b = 50. ft

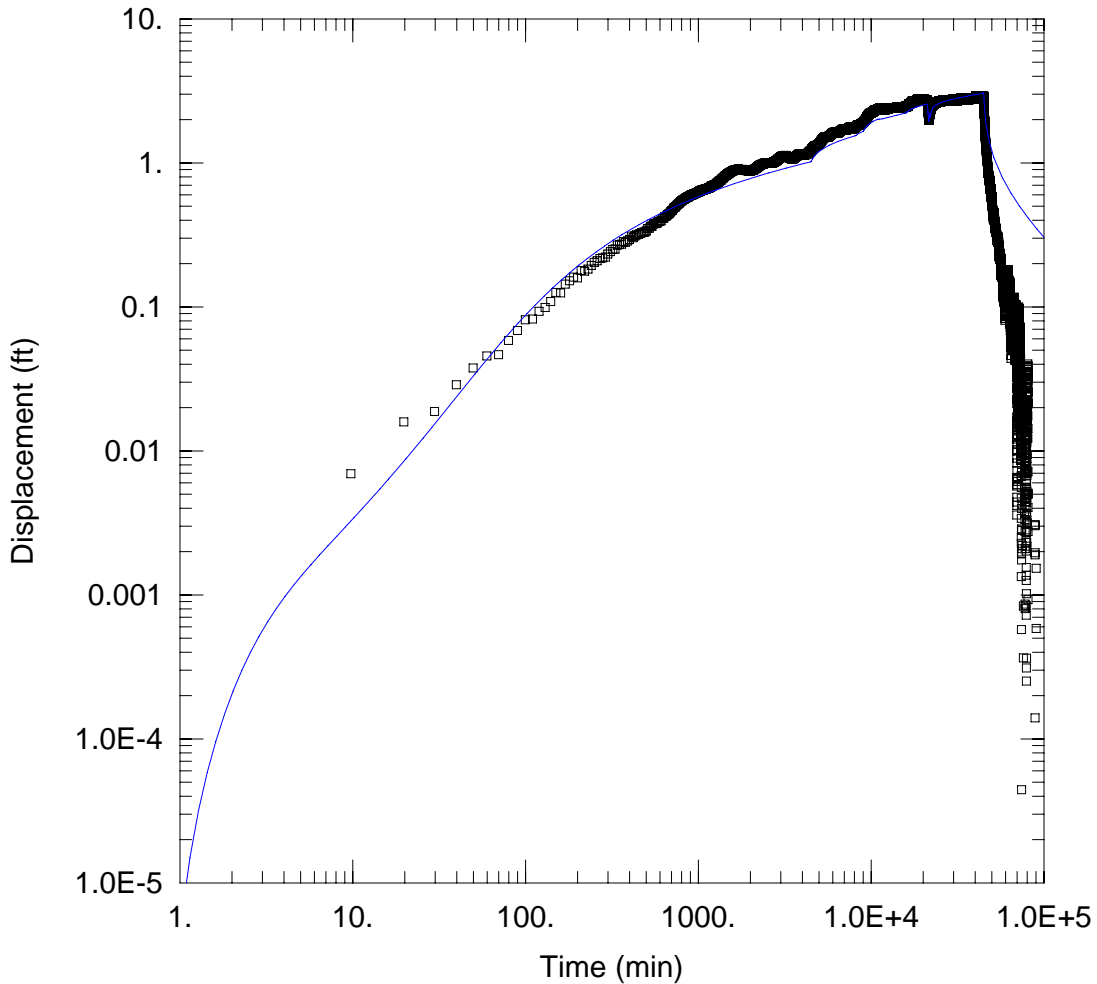

WELL TEST ANALYSIS

Data Set: K:\project\11048\GW\2014GW\Inv\2014 Aq Tests\PW-8\Analysis\PW-3 Moench.aqt
 Date: 03/12/15 Time: 12:31:08

PROJECT INFORMATION

Company: Hydrometrics
 Client: Tintina
 Project: 11048
 Location: Black Butte Copper
 Test Well: PW-8

AQUIFER DATA

Saturated Thickness: 50. ft Slab Block Thickness: 0.5 ft

WELL DATA

Pumping Wells			Observation Wells		
Well Name	X (ft)	Y (ft)	Well Name	X (ft)	Y (ft)
PW-8	1662868.983	16996825.89	□ PW-3	1662824.51	16996177.15

SOLUTION

Aquifer Model: Fractured

Solution Method: Moench w/slab blocks

K = 5.535 ft/day
 K' = 9.086E-5 ft/day
 Sw = 10.
 r(w) = 0.003468 ft

Ss = 1.66E-7 ft⁻¹
 Ss' = 3.132E-6 ft⁻¹
 Sf = 3.25
 r(c) = 0.001072 ft

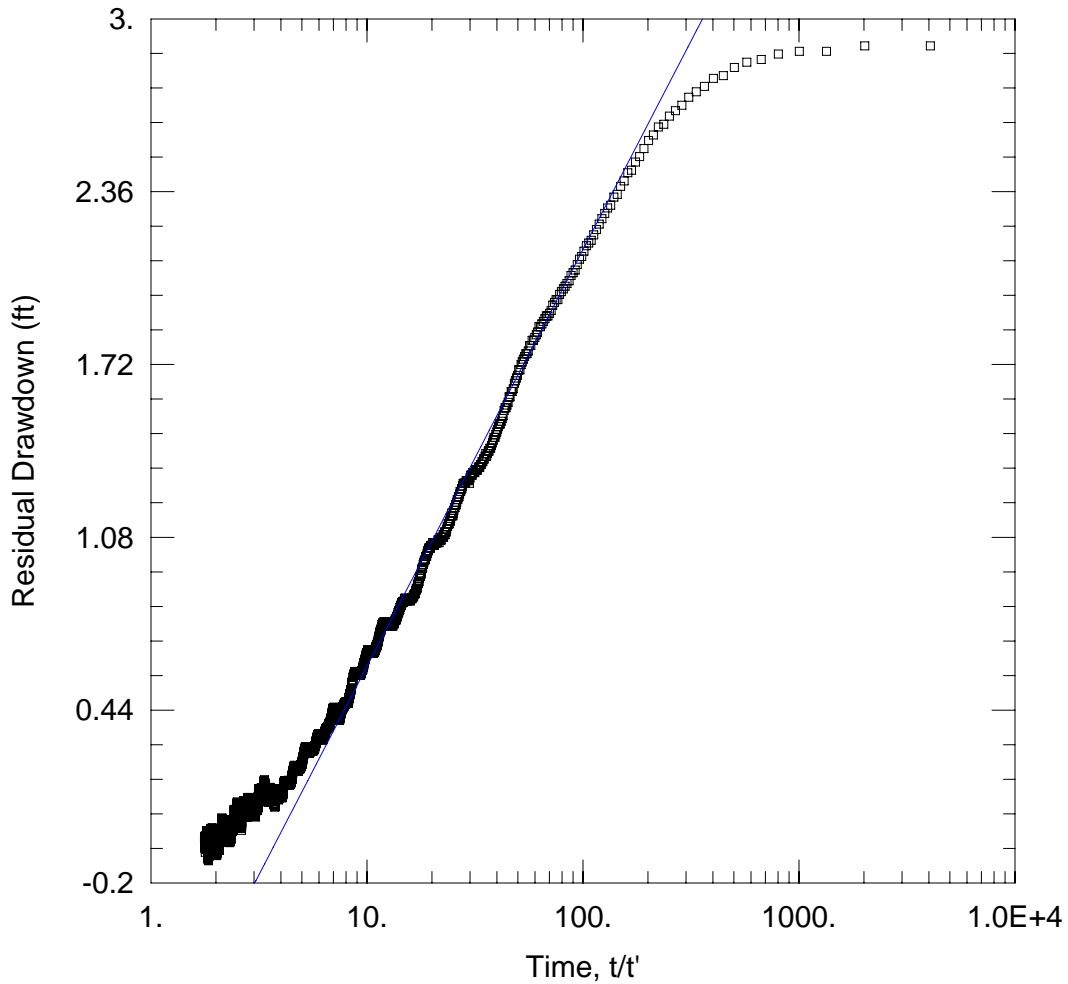

WELL TEST ANALYSIS

Data Set: K:\project\11048\GW\2014GWInv\2014 Aq Tests\PW-8\Analysis\PW-3 TheisRec.aqt
 Date: 03/12/15 Time: 13:01:39

PROJECT INFORMATION

Company: Hydrometrics
 Client: Tintina
 Project: 11048
 Location: Black Butte Copper
 Test Well: PW-8

AQUIFER DATA

Saturated Thickness: 50. ft Anisotropy Ratio (Kz/Kr): 1.

WELL DATA

Pumping Wells			Observation Wells		
Well Name	X (ft)	Y (ft)	Well Name	X (ft)	Y (ft)
PW-8	1662868.983	16996825.89	□ PW-3	1662824.51	16996177.15

SOLUTION

Aquifer Model: Confined Solution Method: Theis (Recovery)
 $T = 228.5 \text{ ft}^2/\text{day}$ $S/S' = 4.076$

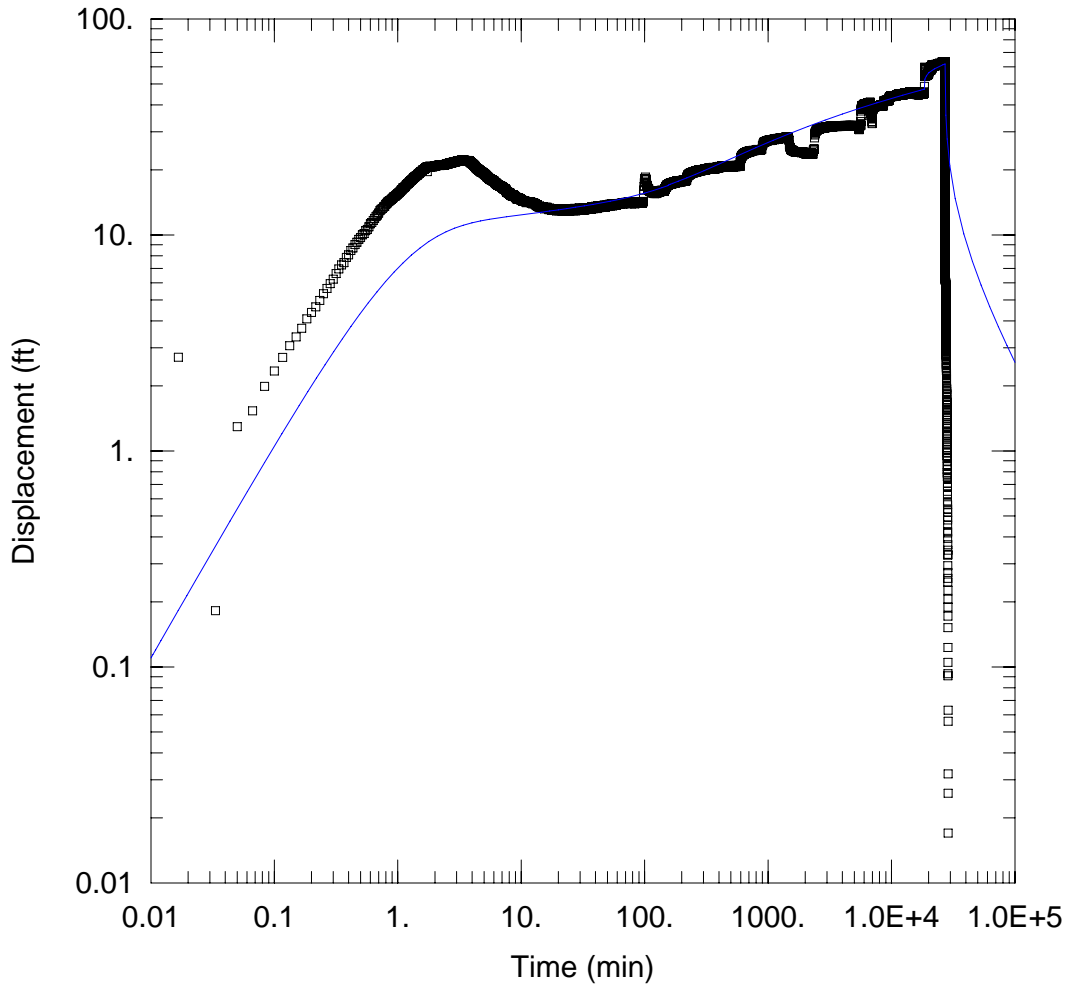

WELL TEST ANALYSIS

Data Set: K:\...\PW-9Moench Flow Averaged.aqt
 Date: 03/12/15

Time: 14:37:14

PROJECT INFORMATION

Company: Hydrometrics
 Client: Tintina
 Project: 11048
 Location: Black Butte Copper
 Test Well: PW-8

AQUIFER DATA

Saturated Thickness: 50. ft

Slab Block Thickness: 1. ft

WELL DATA

Pumping Wells

Observation Wells

Well Name	X (ft)	Y (ft)	Well Name	X (ft)	Y (ft)
PW-09	1662047.972	16996912.35	□ PW-09	1662047.972	16996912.35

SOLUTION

Aquifer Model: Fractured

Solution Method: Moench w/slab blocks

K = 0.198 ft/day
 K' = 0.8633 ft/day
 Sw = -0.075
 r(w) = 0.166 ft

Ss = 1.667E-9 ft⁻¹
 Ss' = 0.2976 ft⁻¹
 Sf = 0.55
 r(c) = 0.1349 ft

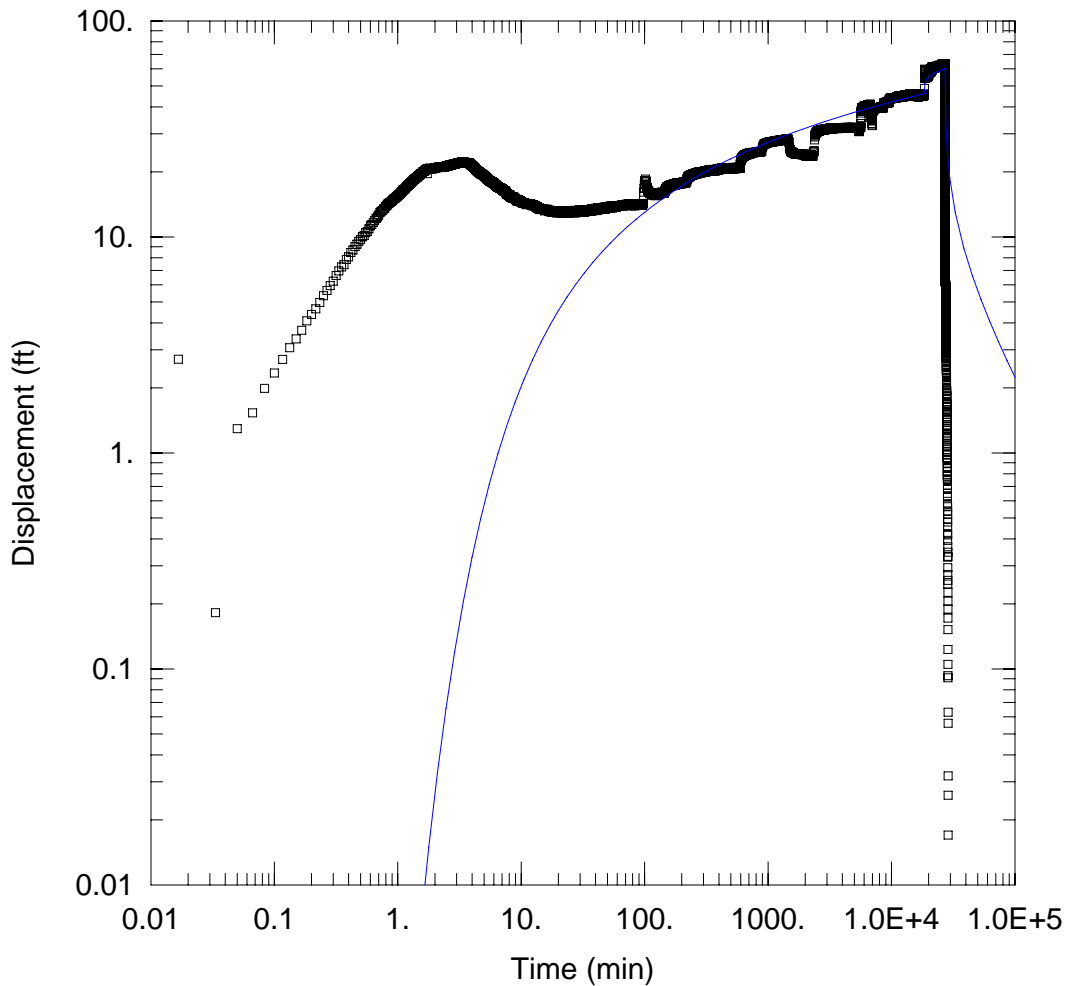

WELL TEST ANALYSIS

Data Set: K:\...\PW-9 Theis Flow Averaged.aqt
 Date: 03/12/15

Time: 14:26:04

PROJECT INFORMATION

Company: Hydrometrics
 Client: Tintina
 Project: 11048
 Location: Black Butte Copper
 Test Well: PW-8

WELL DATA

Pumping Wells			Observation Wells		
Well Name	X (ft)	Y (ft)	Well Name	X (ft)	Y (ft)
PW-09	1662047.972	16996912.35	□ PW-09	1662047.972	16996912.35

SOLUTION

Aquifer Model: Confined

Solution Method: Theis

T = 11.4 ft²/day
 Kz/Kr = 1.

S = 8.998
 b = 50. ft

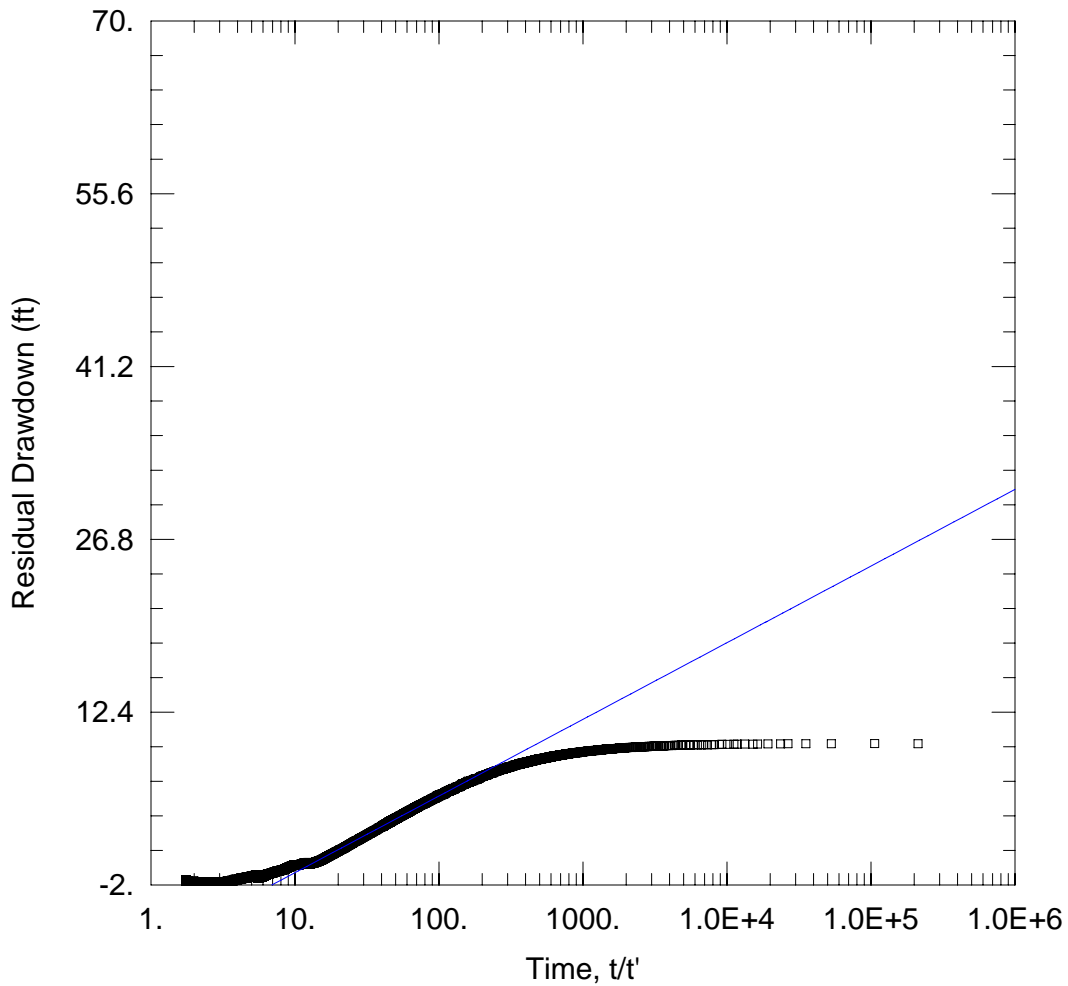

WELL TEST ANALYSIS

Data Set: K:\project\11048\GW\2014GWInv\2014 Aq Tests\PW-9\Analysis\Final Analysis\PW-9 Theis Rec.aqt
 Date: 03/12/15 Time: 15:53:16

PROJECT INFORMATION

Company: Hydrometrics
 Client: Tintina
 Project: 11048
 Location: Black Butte Copper
 Test Well: PW-8

AQUIFER DATA

Saturated Thickness: 50. ft Anisotropy Ratio (Kz/Kr): 1.

WELL DATA

Pumping Wells			Observation Wells		
Well Name	X (ft)	Y (ft)	Well Name	X (ft)	Y (ft)
PW-09	1662047.972	16996912.35	□ PW-09	1662047.972	16996912.35

SOLUTION

Aquifer Model: Confined Solution Method: Theis (Recovery)
 $T = 33.75 \text{ ft}^2/\text{day}$ $S/S' = 14.24$

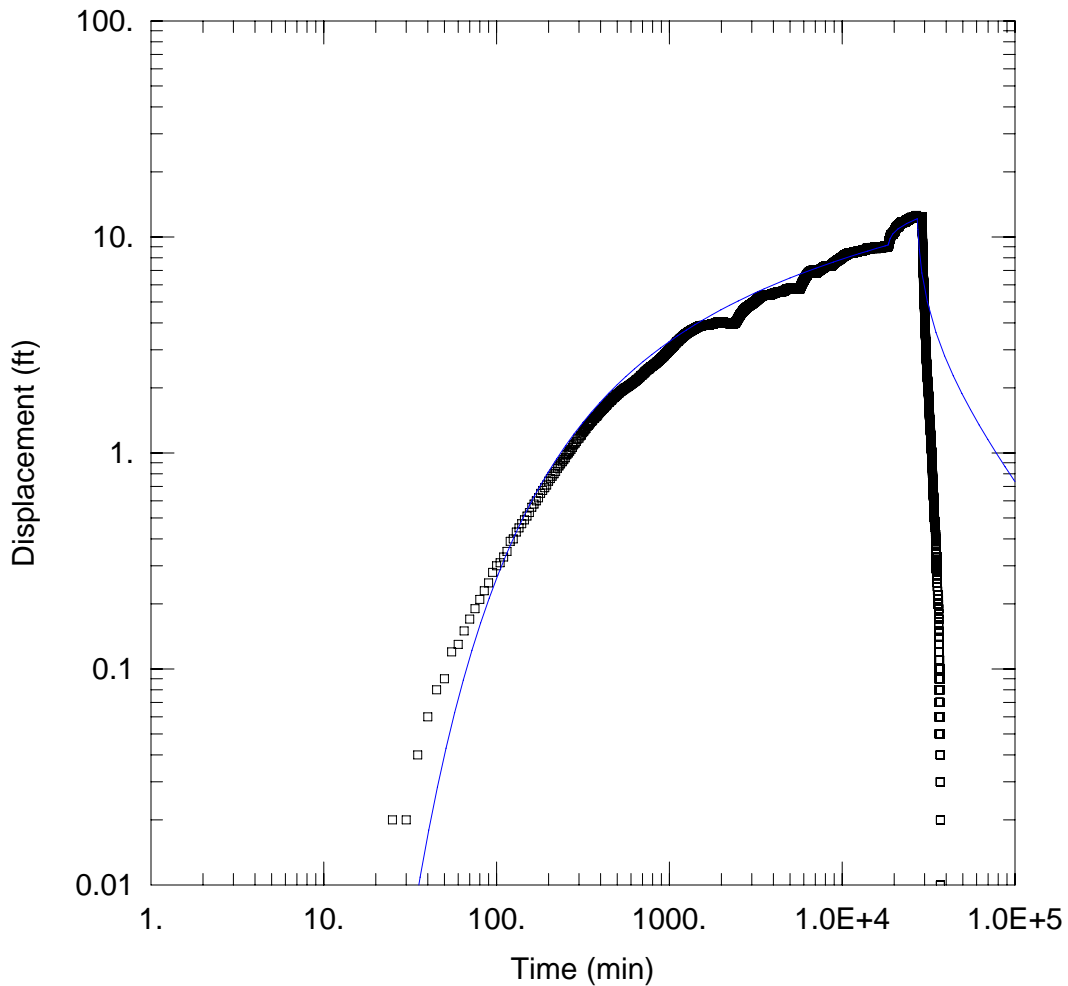

WELL TEST ANALYSIS

Data Set: K:\...\MW-3 Theis Flow Averaged.aqt
 Date: 03/12/15

Time: 14:49:15

PROJECT INFORMATION

Company: Hydrometrics
 Client: Tintina
 Project: 11048
 Location: Black Butte
 Test Well: PW-9
 Test Date: 9/24/14

WELL DATA

Pumping Wells			Observation Wells		
Well Name	X (ft)	Y (ft)	Well Name	X (ft)	Y (ft)
PW-9	1662047.972	16996912.35	□ MW-3	1661672.924	16996972.53

SOLUTION

Aquifer Model: Confined
 $T = 34.62 \text{ ft}^2/\text{day}$
 $Kz/Kr = 1.$

Solution Method: Theis
 $S = 9.007E-5$
 $b = 40. \text{ ft}$

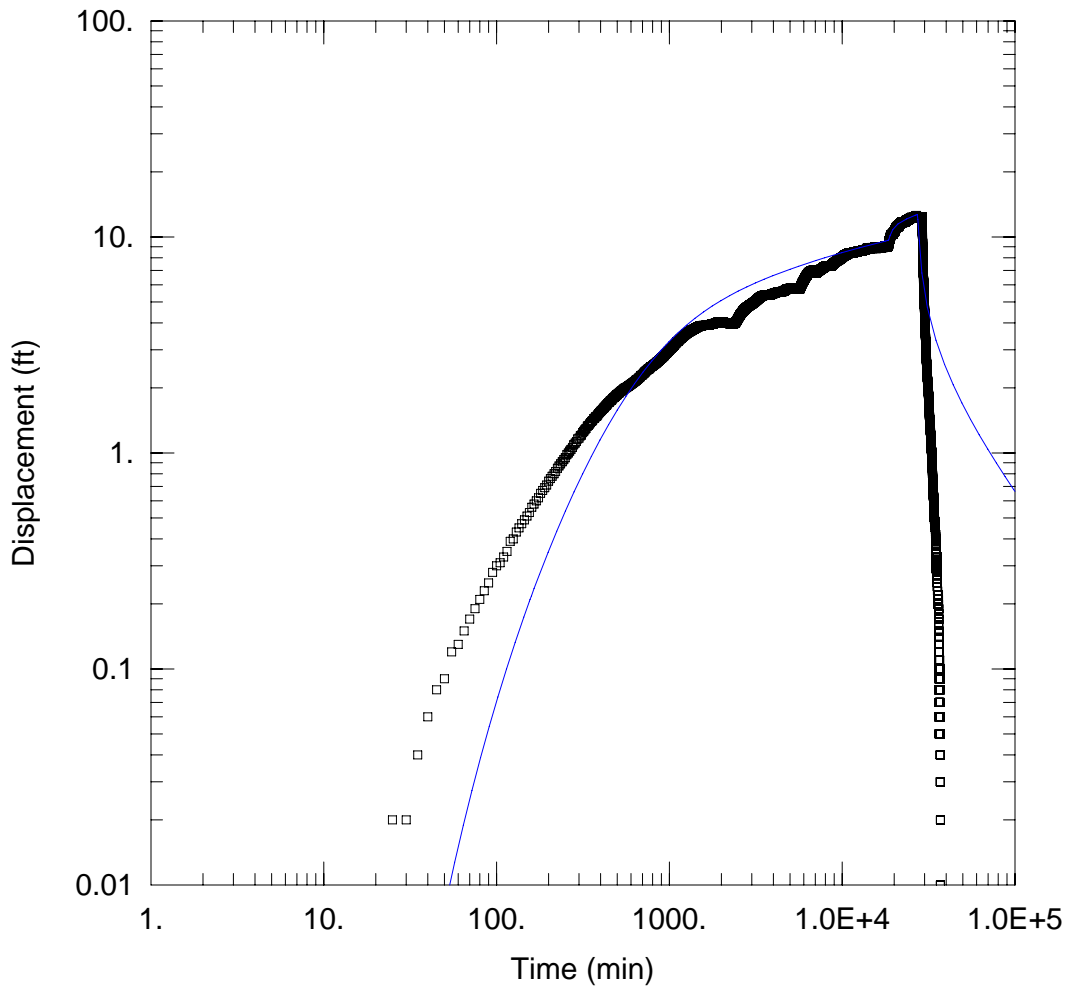

WELL TEST ANALYSIS

Data Set: K:\...\MW-3 Moench Flow Averaged.aqt
 Date: 03/12/15

Time: 14:51:39

PROJECT INFORMATION

Company: Hydrometrics
 Client: Tintina
 Project: 11048
 Location: Black Butte
 Test Well: PW-9
 Test Date: 9/24/14

AQUIFER DATA

Saturated Thickness: 40. ft

Slab Block Thickness: 1. ft

WELL DATA

Pumping Wells			Observation Wells		
Well Name	X (ft)	Y (ft)	Well Name	X (ft)	Y (ft)
PW-9	1662047.972	16996912.35	□ MW-3	1661672.924	16996972.53

SOLUTION

Aquifer Model: Fractured

Solution Method: Moench w/slab blocks

K = 0.9637 ft/day
 K' = 2.389E-9 ft/day
 Sw = 3.625
 r(w) = 0.1698 ft

Ss = 1.157E-6 ft⁻¹
 Ss' = 2.496E-8 ft⁻¹
 Sf = 6.55
 r(c) = 0.1654 ft

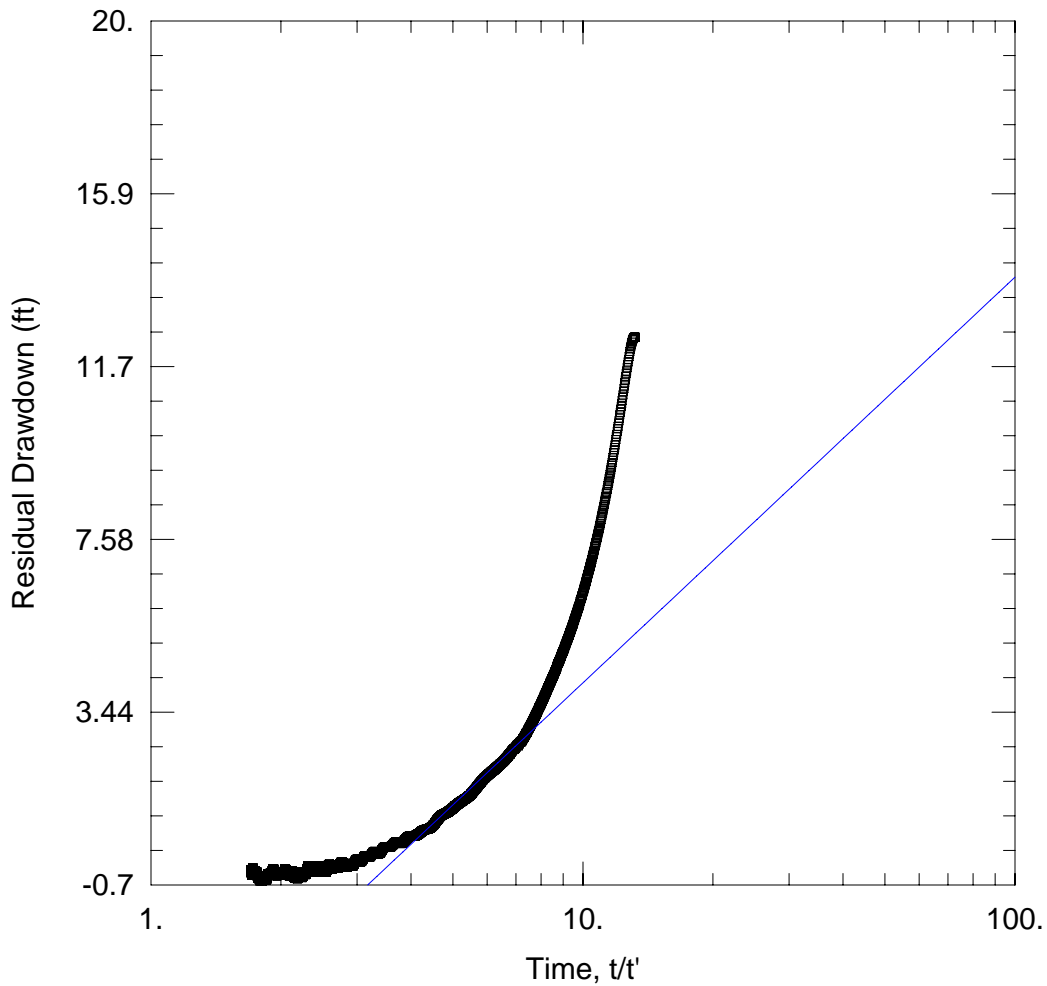

WELL TEST ANALYSIS

Data Set: K:\project\11048\GW\2014GW\Inv\2014 Aq Tests\PW-9\Analysis\Final Analysis\MW-3 Theis Rec.aqt
 Date: 03/12/15 Time: 14:43:54

PROJECT INFORMATION

Company: Hydrometrics
 Client: Tintina
 Project: 11048
 Location: Black Butte
 Test Well: PW-9
 Test Date: 9/24/14

AQUIFER DATA

Saturated Thickness: 40. ft Anisotropy Ratio (Kz/Kr): 1.

WELL DATA

Pumping Wells			Observation Wells		
Well Name	X (ft)	Y (ft)	Well Name	X (ft)	Y (ft)
PW-9	1662047.972	16996912.35	□ MW-3	1661672.924	16996972.53

SOLUTION

Aquifer Model: Confined Solution Method: Theis (Recovery)
 T = 22.18 ft²/day S/S' = 3.749

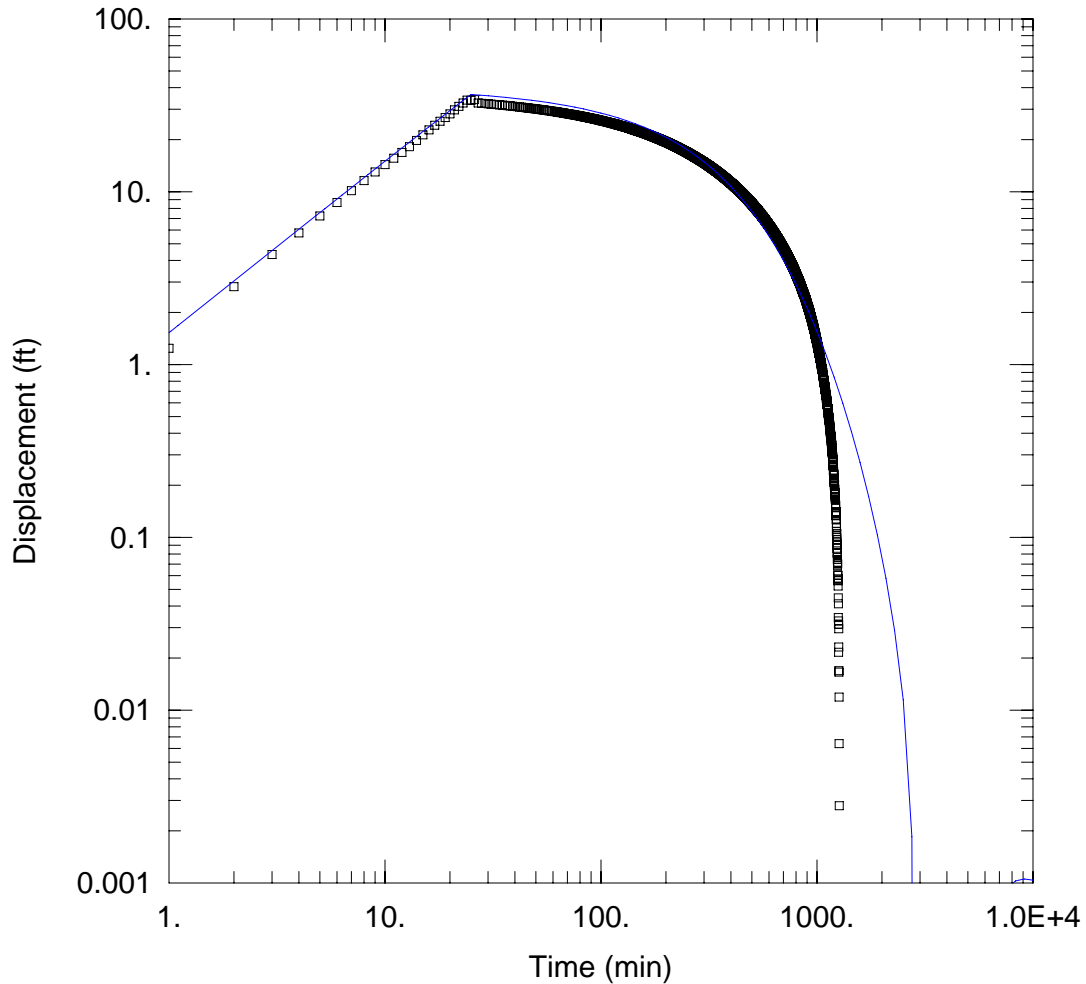

WELL TEST ANALYSIS

Data Set: K:\project\11048\Baseline WRM Report\Appendices\Appendix D - AqTest Analyses\PW10_Moench.aqt
 Date: 08/25/15 Time: 08:21:30

PROJECT INFORMATION

Company: Hydrometrics
 Client: Tintina
 Project: 11048
 Location: Black Butte
 Test Well: PW-10
 Test Date: 3/24/15

AQUIFER DATA

Saturated Thickness: 50 ft Slab Block Thickness: 1 ft

WELL DATA

Pumping Wells			Observation Wells		
Well Name	X (ft)	Y (ft)	Well Name	X (ft)	Y (ft)
pw10	0	0	□ pw10	0	0

SOLUTION

Aquifer Model: Fractured

Solution Method: Moench w/slab blocks

K = 0.007201 ft/day
 K' = 6.432E-6 ft/day
 Sw = -4.85
 r(w) = 0.1667 ft

Ss = 8.532E-12 ft⁻¹
 Ss' = 2.512E-6 ft⁻¹
 Sf = 4.55
 r(c) = 0.1667 ft

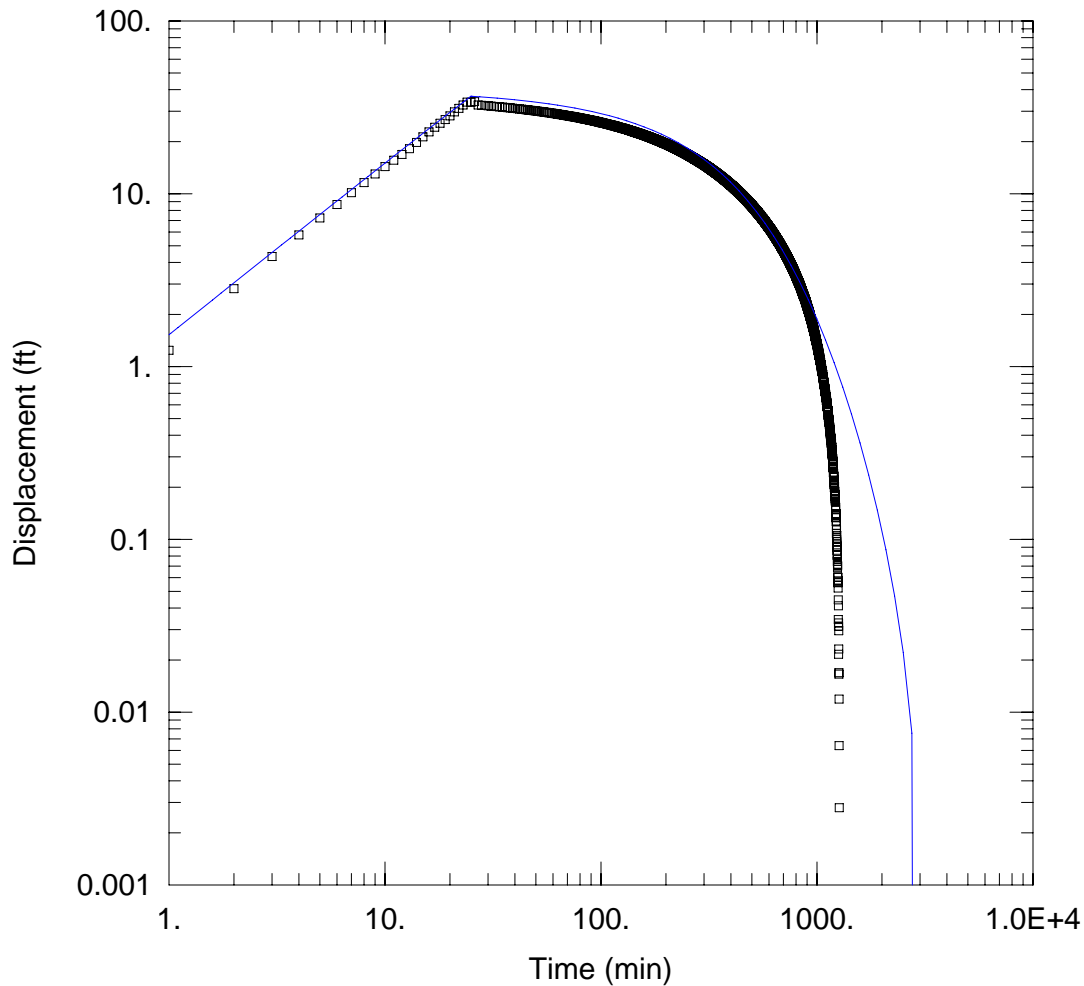

WELL TEST ANALYSIS

Data Set: K:\project\11048\Baseline WRM Report\Appendices\Appendix D - AqTest Analyses\PW10_Barker.aqt
 Date: 08/25/15 Time: 08:22:34

PROJECT INFORMATION

Company: Hydrometrics
 Client: Tintina
 Project: 11048
 Location: Black Butte
 Test Well: PW-10
 Test Date: 3/24/15

AQUIFER DATA

Saturated Thickness: 50. ft Anisotropy Ratio (Kz/Kr): 1.

WELL DATA

Pumping Wells			Observation Wells		
Well Name	X (ft)	Y (ft)	Well Name	X (ft)	Y (ft)
pw10	0	0	□ pw10	0	0

SOLUTION

Aquifer Model: <u>Fractured</u>	Solution Method: <u>Barker</u>
K = <u>0.00572 ft/day</u>	Ss = <u>8.532E-12</u>
K' = <u>6.432E-6 ft/day</u>	Ss' = <u>2.512E-6 ft⁻¹</u>
n = <u>2.055</u>	b = <u>50. ft</u>
Sf = <u>4.55</u>	Sw = <u>-4.85</u>
r(w) = <u>0.1667 ft</u>	r(c) = <u>0.1667 ft</u>

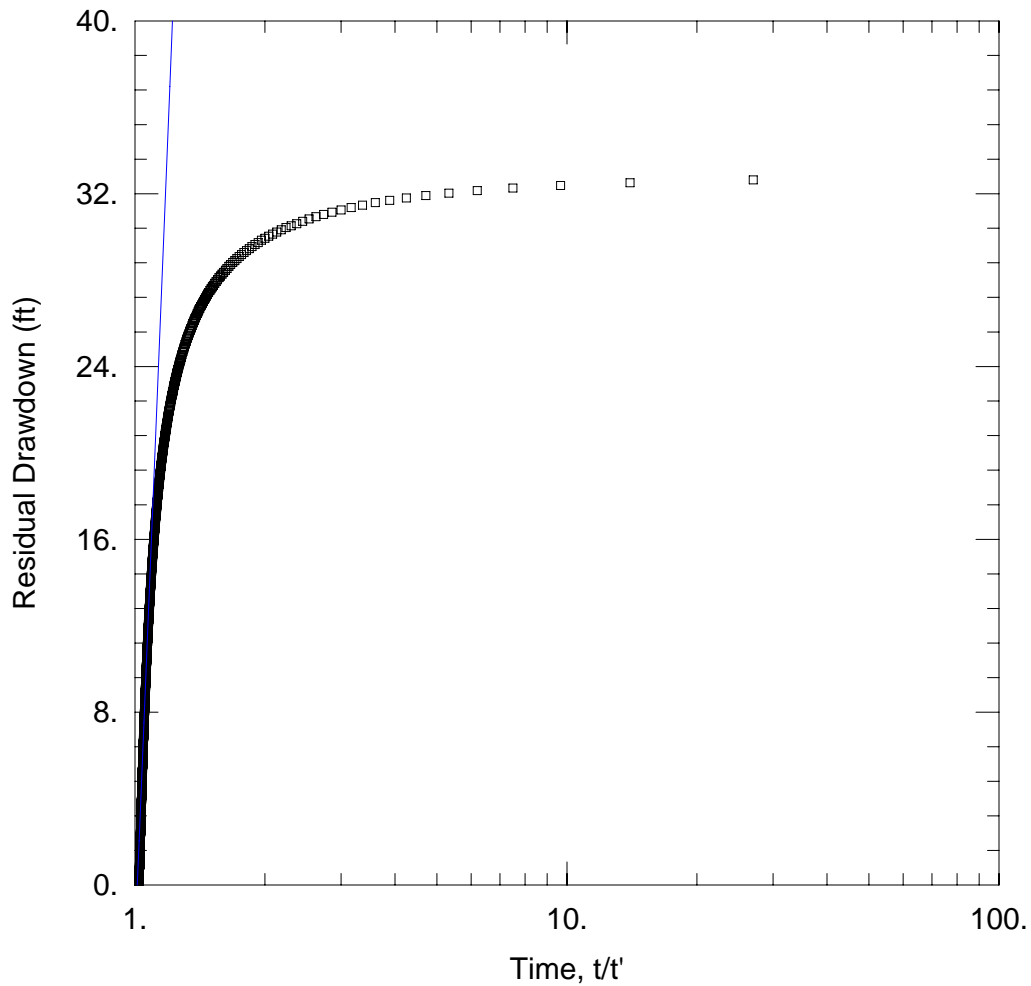

WELL TEST ANALYSIS

Data Set: K:\...\PW10_TheisRec.aqt
 Date: 08/25/15

Time: 08:16:09

PROJECT INFORMATION

Company: Hydrometrics
 Client: Tintina
 Project: 11048
 Location: Black Butte
 Test Well: PW-10
 Test Date: 3/24/15

AQUIFER DATA

Saturated Thickness: 40. ft

Anisotropy Ratio (Kz/Kr): 1.

WELL DATA

Pumping Wells

Observation Wells

Well Name	X (ft)	Y (ft)
pw10	0	0

Well Name	X (ft)	Y (ft)
□ pw10	0	0

SOLUTION

Aquifer Model: Confined

Solution Method: Theis (Recovery)

T = 0.07183 ft²/day

S/S' = 1.013

July 16, 2015

Mr. Greg Bryce
Hydrometrics, Inc.
3020 Bozeman Ave.
Helena, MT 59601

RE: Black Butte Copper Project-Laboratory Testing

Dear Mr. Bryce,

On April 16, 2015, five samples were delivered to Pioneer Technical Service's Bozeman, MT laboratory. The samples were referenced as SC11-008, SC11-036, SC12-129, SC14-164, and SC14-170. The samples were given Lab Nos. G15247 through G15251, respectively. The requested testing was performed in accordance with the following Standards:

- Standard Proctor (ASTM D698), and
- Hydraulic Conductivity of Saturated Porous Material Using a Flexible Wall Permeameter (ASTM D5084).

Table 1

Lab No.	Sample Identification	Confining Pressure (psi)	Hydraulic Conductivity cm/sec
G15247	SC11-008	34.6	1.0×10^{-08}
G15248	SC11-036	37.2	8.1×10^{-09}
G15249	SC12-129	42.0	5.4×10^{-09}
G15250	SC14-164	50.0	2.1×10^{-08}
G15251	SC14-170	41.3	2.5×10^{-07}

At the request of Hydrometrics, the hydraulic conductivity samples were re-molded by compacting the specimens at optimum moisture to a dry unit weight equal to 95% of the uncorrected proctor value. Hydrometrics also requested that the maximum confining pressure was applied after saturation.

The hydraulic conductivity values and confining pressures are provided in Table 1. The moisture-density (proctor) curves and hydraulic conductivity sheets are attached with this report. Thank you for using Pioneer for your geotechnical testing requirements. Please contact us at (406)388-8578 if you have any questions or require any additional information regarding this report.

Sincerely,
PIONEER TECHNICAL SERVICES, INC.



Niki Griffis
Project Scientist/Laboratory Manager



Jeffrey Riedel, P.E.
Senior Geotechnical Engineer

**HYDRAULIC CONDUCTIVITY FOR FLEXIBLE-WALLED TEST SAMPLES
FALLING HEAD APPARATUS, ASTM D5084**

Client:	Hydrometrics				Project: Black Butte Copper						
Sample Description:	SC11-008										
	G15247										
Test Specimen											
Dry Density (pcf):	126.6										
% Max. ASTM D-698 (uncorrected):	95%										
Specimen Length (cm):	15.24										
Specimen Diameter (cm):	7.11										
Testing Equipment											
Height Inlet Above Floor (cm):											
Height Outlet Above Bench (cm): 21.9											
Area of Standpipe (cm ²): 0.899											
Increment Number	Initial Reading	Initial Reading	Final Reading	Final Reading	Time Increment	Applied Pressure Differential	Initial Head	Final Head	Average Hydraulic Gradient	Hydraulic Conductivity	Hydraulic Conductivity at 20 C
	(cm ³)	(cm ³)	(cm ³)	(cm ³)	(min.)	(psi)	(cm)	(cm)	(cm/cm)	(cm/sec)	(cm/sec)
1	0.2	24	0.7	23.3	1605	2.4	194.80	193.49	12.74	1.2E-08	1.1E-08
2	0.7	23.3	1.8	21.6	4013	2.5	200.52	197.45	13.06	1.1E-08	1.0E-08
3	1.8	21.6	2.3	21.15	1408	2.5	197.45	196.41	12.92	1.1E-08	1.0E-08
4	2.3	21.15	2.65	20.6	1468	2.4	189.38	188.39	12.39	1.0E-08	9.6E-09
5	2.65	20.6	3.2	20.1	1483	2.4	188.39	187.24	12.32	1.2E-08	1.1E-08
Average Hydraulic Conductivity of Last Four Test Increments =									1.0E-08	cm/sec	
$k = (aL/At) \ln (h1/h2)$											
Water Content Before Test						Water Content After Test					
Tare #						Tare #					
Wet Soil + Tare (grams)	1312.30					Wet Soil + Tare (grams)	1806.00				
Dry Soil + Tare (grams)	1211.00					Dry Soil + Tare (grams)	1677.60				
Tare Weight (grams)	0.00					Tare Weight (grams)	466.60				
Water Content (%)	8.36					Water Content (%)	10.60				
Source	Specimen					Source	Specimen				

**HYDRAULIC CONDUCTIVITY FOR FLEXIBLE-WALLED TEST SAMPLES
FALLING HEAD APPARATUS, ASTM D5084**

Client:	Hydrometrics				Project: Black Butte Copper						
Sample Description:	SC11-036										
	G15248										
Test Specimen											
Dry Density (pcf):			124.2								
% Max. ASTM D-698(uncorrected):			95%								
Specimen Length (cm):			15.24								
Specimen Diameter (cm):			7.11								
Testing Equipment											
Height Inlet Above Floor (cm):											
Height Outlet Above Bench (cm): 21.9											
Area of Standpipe (cm ²): 0.912											
Increment Number	Initial Reading	Initial Reading	Final Reading	Final Reading	Time Increment	Applied Pressure Differential	Initial Head	Final Head	Average Hydraulic Gradient	Hydraulic Conductivity	Hydraulic Conductivity at 20 C
	(cm ³)	(cm ³)	(cm ³)	(cm ³)	(min.)	(psi)	(cm)	(cm)	(cm/cm)	(cm/sec)	(cm/sec)
1	0.5	40.6	0.8	40.2	1395	1.9	177.52	176.75	11.62	9.1E-09	8.5E-09
2	0.8	40.2	1.1	39.8	1327	2.0	183.78	183.02	12.03	9.2E-09	8.6E-09
3	1.1	39.8	1.5	39.4	1503	1.9	175.99	175.11	11.52	9.7E-09	9.0E-09
4	1.5	39.4	1.7	38.8	1747	2.1	189.17	188.29	12.38	7.8E-09	7.3E-09
5	1.7	38.8	2.5	37.8	4013	2.0	181.26	179.29	11.83	8.0E-09	7.5E-09
Average Hydraulic Conductivity of Last Four Test Increments =									8.1E-09	cm/sec	
$k = (aL/At) \ln (h1/h2)$											
Water Content Before Test						Water Content After Test					
Tare #						Tare #					
Wet Soil + Tare (grams)	1282.70					Wet Soil + Tare (grams)	1433.10				
Dry Soil + Tare (grams)	1188.54					Dry Soil + Tare (grams)	1300.50				
Tare Weight (grams)	0.00					Tare Weight (grams)	111.96				
Water Content (%)	7.92					Water Content (%)	11.16				
Source	Specimen					Source	Specimen				

**HYDRAULIC CONDUCTIVITY FOR FLEXIBLE-WALLED TEST SAMPLES
FALLING HEAD APPARATUS, ASTM D5084**

Client:	Hydrometrics					Project:	Black Butte Copper				
Sample Description:	G15249										
Test Specimen											
Dry Density (pcf):		122.4									
% Max. ASTM D-698 (uncorrected)		95%									
Specimen Length (cm):		15.24									
Specimen Diameter (cm):		7.11									
Testing Equipment											
		Height Inlet Above Floor (cm):									
		Height Outlet Above Bench (cm):				21.9					
		Area of Standpipe (cm ²):				0.912					
Increment Number	Initial Reading Inlet (cm³)	Initial Reading Effluent (cm³)	Final Reading Inlet (cm³)	Final Reading Effluent (cm³)	Time Increment (min.)	Applied Pressure Differential (psi)	Initial Head (cm)	Final Head (cm)	Average Hydraulic Gradient (cm/cm)	Hydraulic Conductivity (cm/sec)	Hydraulic Conductivity at 20 C (cm/sec)
1	15	27.6	15.2	27.4	1605	2.0	154.41	153.97	10.12	5.2E-09	4.8E-09
2	15.2	27.4	15.4	27.1	1393	2.0	153.97	153.42	10.09	7.5E-09	7.0E-09
3	15.4	27.1	15.55	26.9	1485	2.0	153.42	153.04	10.05	4.9E-09	4.7E-09
4	15.55	26.9	15.9	26.5	2752	2.0	153.04	152.22	10.02	5.7E-09	5.4E-09
5	15.9	26.5	16.4	26.1	2780	2.0	152.22	151.23	9.96	6.8E-09	6.4E-09
6	16.4	26.1	16.5	25.9	1443	2.0	151.23	150.90	9.91	4.4E-09	4.1E-09
7	16.5	25.9	16.7	25.7	1456	2.0	150.90	150.46	9.89	5.8E-09	5.7E-09
Average Hydraulic Conductivity of Last Four Test Increments =									5.4E-09	cm/sec	
k = (aL/At) ln (h1/h2)											
Water Content Before Test						Water Content After Test					
Tare #						Tare #					
Wet Soil + Tare (grams)	1260.70					Wet Soil + Tare (grams)	1417.40				
Dry Soil + Tare (grams)	1167.14					Dry Soil + Tare (grams)	1277.70				
Tare Weight (grams)	0.00					Tare Weight (grams)	110.56				
Water Content (%)	8.02					Water Content (%)	11.97				
Source	Specimen					Source	Specimen				

**HYDRAULIC CONDUCTIVITY FOR FLEXIBLE-WALLED TEST SAMPLES
FALLING HEAD APPARATUS, ASTM D5084**

Client:	Hydrometrics				Project: Black Butte Copper						
Sample Description:	SC14-164										
	G15250										
Test Specimen											
Dry Density (pcf):	128.3										
% Max. ASTM D-698 (uncorrected):	95%										
Specimen Length (cm):	15.24										
Specimen Diameter (cm):	7.11										
Testing Equipment											
Height Inlet Above Floor (cm):											
Height Outlet Above Bench (cm): 21.9											
Area of Standpipe (cm ²): 0.912											
Increment Number	Initial Reading	Initial Reading	Final Reading	Final Reading	Time Increment	Applied Pressure Differential	Initial Head	Final Head	Average Hydraulic Gradient	Hydraulic Conductivity	Hydraulic Conductivity at 20 C
	(cm ³)	(cm ³)	(cm ³)	(cm ³)	(min.)	(psi)	(cm)	(cm)	(cm/cm)	(cm/sec)	(cm/sec)
1	7.8	26.4	8.6	25.6	1299	2.0	160.99	159.23	10.51	2.5E-08	2.3E-08
2	8.6	25.6	9.5	24.8	1441	2.4	187.35	185.49	12.23	2.0E-08	1.9E-08
3	9.5	24.8	10.3	23.8	1429	2.7	206.58	204.61	13.49	2.0E-08	1.9E-08
4	10.3	23.8	11.3	22.8	1468	2.3	176.49	174.29	11.51	2.5E-08	2.4E-08
Average Hydraulic Conductivity of Last Four Test Increments =									2.1E-08	cm/sec	
$k = (aL/At) \ln (h1/h2)$											
Water Content Before Test						Water Content After Test					
Tare #						Tare #					
Wet Soil + Tare (grams)	1309.70					Wet Soil + Tare (grams)	1456.00				
Dry Soil + Tare (grams)	1228.48					Dry Soil + Tare (grams)	1341.00				
Tare Weight (grams)	0.00					Tare Weight (grams)	112.52				
Water Content (%)	6.61					Water Content (%)	9.36				
Source	Specimen					Source	Specimen				

**HYDRAULIC CONDUCTIVITY FOR FLEXIBLE-WALLED TEST SAMPLES
FALLING HEAD APPARATUS, ASTM D5084**

Client:	Hydrometrics					Project:	Black Butte Copper				
Sample Description:	SC14-170										
	G15251										
Test Specimen											
Dry Density (pcf):		129.3									
% Max. ASTM D-698(uncorrected):		95%									
Specimen Length (cm):		15.24									
Specimen Diameter (cm):		7.11									
Testing Equipment											
		Height Inlet Above Floor (cm):									
		Height Outlet Above Bench (cm):				21.9					
		Area of Standpipe (cm ²):				0.912					
Increment Number	Initial Reading Inlet (cm ³)	Initial Reading Effluent (cm ³)	Final Reading Inlet (cm ³)	Final Reading Effluent (cm ³)	Time Increment (min.)	Applied Pressure Differential (psi)	Initial Head (cm)	Final Head (cm)	Average Hydraulic Gradient (cm/cm)	Hydraulic Conductivity (cm/sec)	Hydraulic Conductivity at 20 C (cm/sec)
1	5.4	39.7	16.5	28.5	1618	1.8	164.13	139.69	9.97	2.9E-07	2.7E-07
2	16.5	28.5	25.4	19.7	1243	2.2	167.81	148.41	10.37	2.9E-07	2.7E-07
3	25.4	19.7	32.4	12.8	1429	1.9	127.32	112.09	7.85	2.6E-07	2.5E-07
4	32.4	12.8	40.3	4.9	1395	2.8	175.36	158.04	10.94	2.2E-07	2.0E-07
Average Hydraulic Conductivity of Last Four Test Increments =									2.5E-07	cm/sec	
$k = (aL/At) \ln (h1/h2)$											
Water Content Before Test						Water Content After Test					
Tare #						Tare #					
Wet Soil + Tare (grams)	1303.40					Wet Soil + Tare (grams)	1464.30				
Dry Soil + Tare (grams)	1232.58					Dry Soil + Tare (grams)	1345.10				
Tare Weight (grams)	0.00					Tare Weight (grams)	112.52				
Water Content (%)	5.75					Water Content (%)	9.67				
Source	Specimen					Source	Specimen				

COMPACTION TEST REPORT

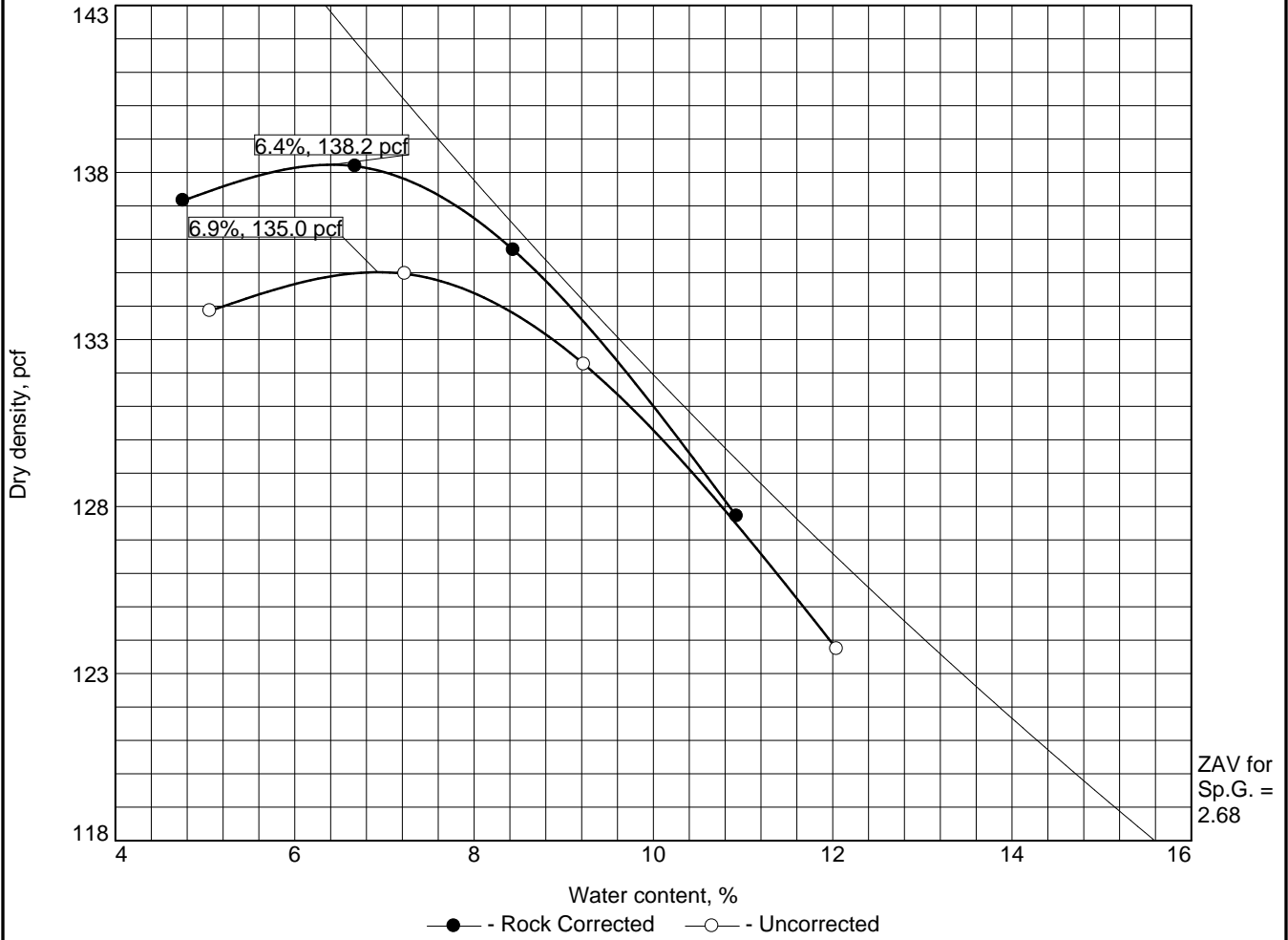

Test specification: ASTM D 698-07 Method B Standard
 ASTM D 4718-87 Oversize Corr. Applied to Each Test Point

Elev/ Depth	Classification		Nat. Moist.	Sp.G.	LL	PI	% > 3/8 in.	% < No.200
	USCS	AASHTO						
							11.7	

ROCK CORRECTED TEST RESULTS	UNCORRECTED	MATERIAL DESCRIPTION
Maximum dry density = 138.2 pcf	135.0 pcf	
Optimum moisture = 6.4 %	6.9 %	

<p>Project No. Client: Hydrometrics</p> <p>Project: Black Butte Copper</p> <p>○ Source of Sample: SC14-164 Sample Number: G15250</p> <p style="text-align: center;">Pioneer Technical Services, Inc. 106 Pronghorn Trail, Suite A - Bozeman, MT 59718 Ph. 406-388-8578 - Fax 406-388-8579</p>	<p>Remarks: Oversize Specific Gravity assumed at 2.70</p>
---	--

Figure

Tested By: NG

